

Pneumatic Cylinders Economair®

Features

Series 23, 24, & 28

Economair round cylinders are medium to heavy-duty units that can be installed anywhere that a repairable cylinder is desired. Prelubed, they're suitable for operation without externally applied lubrication. Unique endcap retention design provides a concentric assembly, resulting in a service life superior to tie rod cylinder construction.

- Cylinder heads are high tensile strength aluminum alloy, retained by a feed ring wire, a simple design that eliminates excess cylinder weight and bulk.
- The barrel I.D. is hard-coated aluminum with a Rockwell C60 hardness. A finish of 16 microinches or better insures low friction and smooth operation.
- Piston rod is ground and polished, hard-chrome plated steel for minimum friction and maximum packing life. Optional 303 stainless steel is excellent for corrosion resistance and washdown applications (303 stainless steel is standard on 1-1/8-inch bore cylinders).
- Adjustable cushions provide excellent control of cylinder deceleration. Full range adjustability (except fixed cushions on 1-1/8-inch bore).
- High grade, self-lubricating bronze rod bearing reduces friction and promotes smooth operation.
- Piston seal selection insures job-matched performance - Buna N O-ring, Low Friction U-cup and self-lubricating packings available.
- Wear compensating rod wiper protects internal seals and parts from dirt, grit and debris.
- NPTF dry seal pipe threads on ports.
- Optional self-lubricating U-cup seals reduce drag and promote extra cylinder life.
- Cylinder is repairable so instead of buying complete new units, repair kits can be used.



Performance Specifications

Bore Sizes:	1-1/8", 1-1/2", 2", 2-1/2", 3" and 4"
Maximum Output Force:	2,513 pounds (4-inch bore).
Air Pressure:	To 200 p.s.i. (14 bar). May be operated hydraulically (200 p.s.i., nonshock).
Operating Temperature Range:	0° to 180° F (-18° to 82° C).
Seals:	Viton seals available for high heat applications. Consult factory.
Notes:	Wide range of mounting styles and attachable mounting hardware/ accessories allows cylinders to be applied in nearly any pneumatic application.



U-cup and Magnetic Piston Options

Pneumatic Cylinders Economair®

Ordering

Include dashes (-). The dashes are significant.

Series 23, 24, & 28

SERIES NO.

- 23 Noncushioned
- 24 Cushioned, Both Ends
- 28 Magnetic Piston, Cushioned Both Ends

NOTE: 1-1/8 inch bore not available

BORE SIZE

- 18 1-1/8 in
- 15 1-1/2 in
- 20 2 in
- 25 2-1/2 in
- 30 3 in
- 40 4 in

CYLINDER TYPE

- 1 Double Acting, Rear Tang
- 09 Standard Rod
- 5 Double Acting, No Rear Tang
- 2 Double Acting, Double Rod

NOTE: Not Available in Series 28

Economair mounts must be ordered separately, see below.

2X XX
- X X
X9 -
XXX

(1" Increments, 1" through 10" plus 1 1/2", 2 1/2" and 3 1/2")

STROKE LENGTH

WHOLE INCHES

- = 0 in
- = 1 in
- = 2 in
- = 3 in
- = 4 in
- 00 = 5 in
- 01 = 6 in
- 02 \diamond
- 03 to
- 04 99 in
- 05

- 0 = 0 in
- 1 = 1/8 in
- 2 = 1/4 in
- 3 = 3/8 in
- 4 = 1/2 in
- 5 = 5/8 in
- 6 = 3/4 in
- 7 = 7/8 in

06 \diamond to 99

OPTIONS

- 89 303 Stainless Steel Rod Standard on 1-1/8" bore cylinder.

PACKING

- 4 Lip, Nitrile (pneumatic)
- 5 Lip, Self-Lubricating (low friction)
- 6 Lip, Viton

These packings add one inch to cylinder length.
Viton not available in Series 28

- 0 O-Ring, Nitrile
- 2 O-Ring, Low Friction
- 3 O-Ring, Viton

Note: Highlighted selections denote most popular models.

Mounts

1-1/8	Cylinder Bore (Inches)					
	1-1/2	2	2-1/2	3	4	
L-Mount (2 qty.)	20533	20534	20534	20535	20535	20536
Flange Mount	20537	20538	20538	20539	20539	20540
Clevis Bracket	20546	20547	20547	20548	20548	20549
Mounting Nut (2 qty.)	-	20530	20530	20531	20531	20532
Trunnion	-	20556	20557	20558	-	-
Aluminum Rod Clevis	-	20542	20543	20544	20544	20545
Steel Rod Clevis	20541	115906	115907	115908	115908	115909

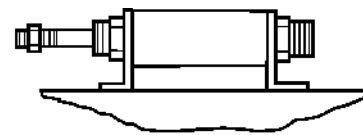

L-Mount

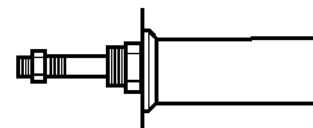

Flange Mount



Mounting Nut

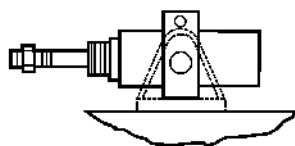

Trunnion

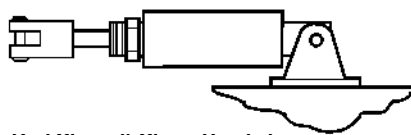

Rod Clevis & Clevis Bracket

Note: Order cylinder, rod clevis and clevis bracket separately.
Every Economair Cylinder includes rod nut.
Trunnion Mount does not include pillow block.

Pneumatic Cylinders Economair® - Dimensional Data

Dimensional Data

Series 23, 24, & 28

Reference	Cylinder Bore (Inches)					
	1-1/8	1-1/2	2	2-1/2	3	4
Rod dia.	0.38	0.50	0.63	0.75	0.75	1.00
A	1.625	3.00	3.00	4.00	4.00	5.00
B	1.281	1.50	1.50	2.00	2.00	2.625
C	1.00	1.688	1.688	2.25	2.25	3.00
D-dia*	.250	.250	.250	.375	.375	.438
E	.250	.313	.313	.375	.375	.438
F	.625	.906	.906	1.219	1.219	1.469
G	.375	.500	.500	.625	.625	.750
H	1.00	1.531	1.531	2.094	2.094	2.531
J	.750	1.00	1.00	1.25	1.25	1.188
K	.375	.469	.469	.781	.781	.781
L-HEX	1.0625	1.438	1.438	2.0625	2.0625	2.50
M-dia.	1.25	1.75	1.75	2.438	2.438	2.938
N	2.00	2.50	2.50	3.375	3.375	4.00
P	2.50	3.25	3.25	4.50	4.50	5.188
Q	.688	.594	.594	.719	.719	.844
R	1.219	1.750	1.750	2.375	2.375	3.00
S	.313	.313	.313	.375	.375	.438
T	2.250	3.00	3.00	4.00	4.00	5.00
U	1.75	2.25	2.25	3.00	3.00	3.75
V	1.75	2.25	2.25	2.688	2.688	3.375
W	1.406	1.75	1.75	2.0625	2.0625	2.625
X	.750	1.00	1.00	1.25	1.25	1.50
Y-dia.*	.250	.3125	.3125	.438	.4375	.625
Z	.656	.688	.688	.875	.875	1.063
ZZ	.3125	.375	.375	.500	.500	.625
TA	3.125	4.125	4.125	5.375	5.625	7.125
TB	2.25	3.00	3.00	3.75	4.25	5.50
TC-dia.	.438	.500	.500	.750	.750	.750
TD	2.00	2.625	3.125	4.00	4.50	5.75
TE	.875	1.125	1.375	1.875	2.125	2.688
TF	.750	1.250	1.250	1.50	1.50	1.50
TG-dia.*	.250	.3125	.3125	.4375	.4375	.500
TH-Thd.	3/8-16	1/2-13	5/8-11	3/4-10	3/4-10	1-8
TK	-	2.0625	2.0625	2.50	2.50	3.25
TL	-	.875	.875	1.00	1.00	1.325
TM	-	1.0625	1.0625	1.438	1.438	1.938
TN	-	1.813	1.00	1.813	1.813	1.50

*Bolt or pin diameter

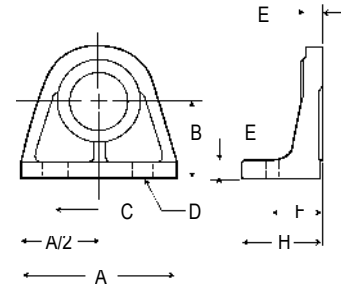

L-Type

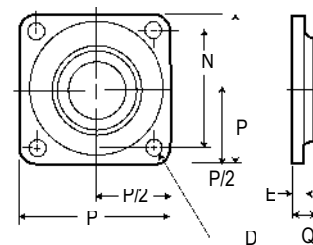

Flange

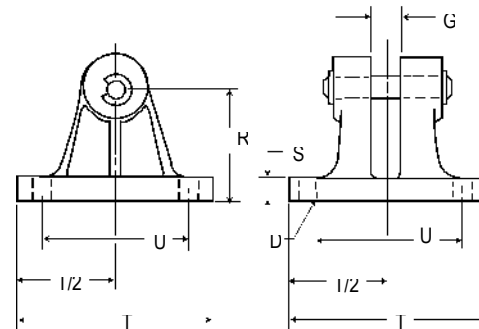

Clevis Bracket

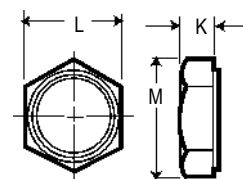

Mounting Nut

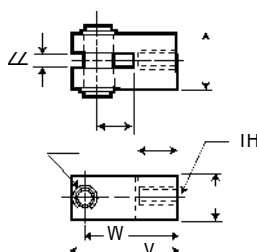

Steel Rod Clevis

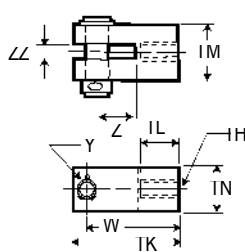

Aluminum Rod Clevis

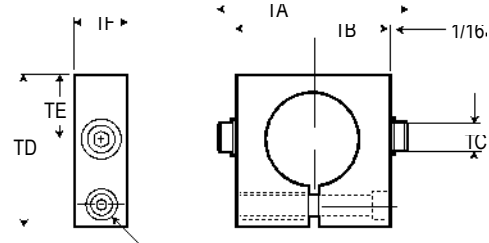

Trunnion

Pneumatic Cylinders Economair® - Dimensional Data

Dimensional Data

Series 23, 24, & 28 (Double Acting with Tang)

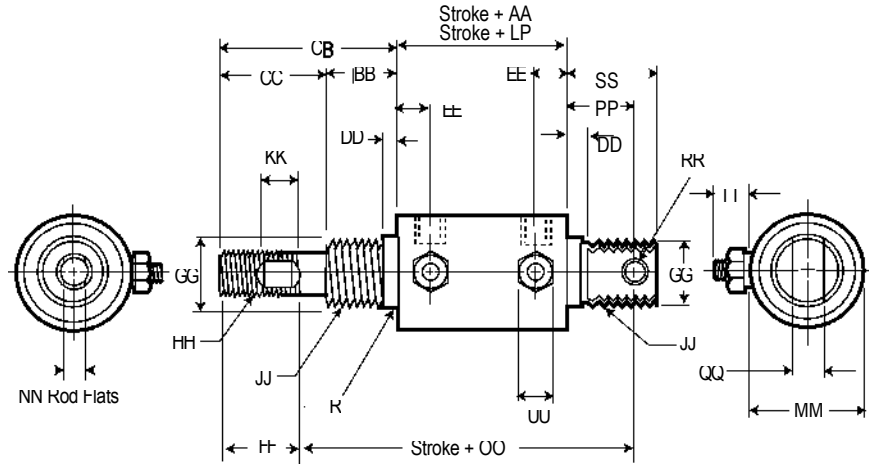

AA = Double acting with O-ring or low friction packing.

(Double Acting, No Tang)

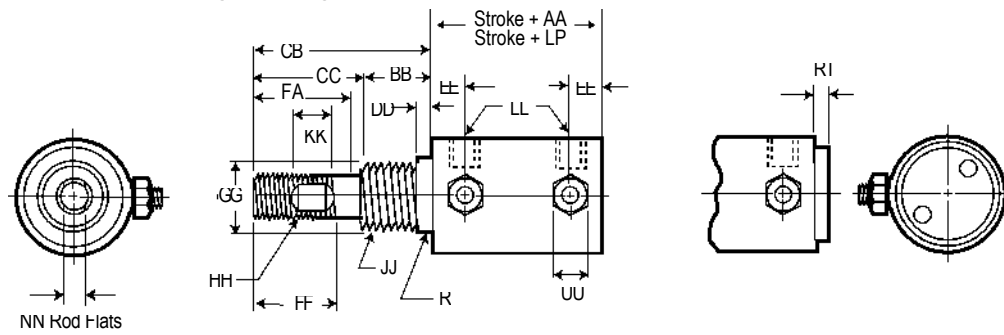

AA = Double acting with O-ring or low friction packing.

(Double Acting, Double Ended)

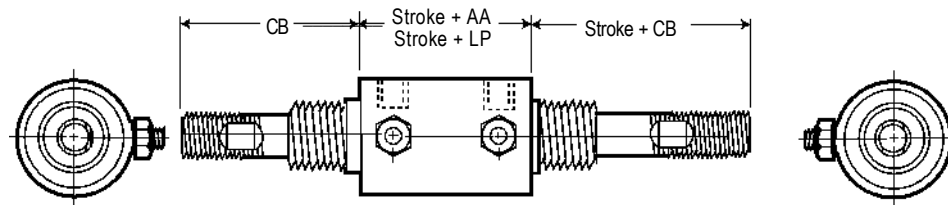

Pneumatic Cylinders Economair® - Dimensional Data

Dimensional Data

Series 23, 24, & 28

Dimensional Reference	Cylinder Bore (Inches)					
	1-1/8	1-1/2	2	2-1/2	3	4
Rod Diameter	.38	.50	.63	.75	.75	1.00
Stroke Factor AA*	2.031	2.625	2.625	2.875	2.875	4.00
Stroke Factor LP**	3.031	3.625	3.625	3.875	3.875	5.00
BB	.750	1.00	1.00	1.250	1.250	1.250
CB	1.750	2.438	2.438	2.938	2.938	3.500
CC	1.00	1.438	1.438	1.688	1.688	2.250
DD	.125	.219	.219	.344	.344	.406
EE	.422	.516	.516	.563	.563	.813
FA	.781	1.156	1.156	1.375	1.375	1.750
FFS	.875	1.250	1.250	1.50	1.50	1.875
(±.002) GG	.748	1.057	1.057	1.432	1.432	1.777
(UNC-2A) HH	3/8-16	1/2-13	5/8-11	3/4-10	3/4-10	1-8
JJ	3/4-16	1-1/16-18	1-1/16-18	1-3/8-12	1-3/8-12	1-3/4-12
KK	UNF-2A	UNEF-2A	UNEF-2A	UNF-2A	UNF-2A	UN-2A
(NPTF) LL	.313	.500	.500	.500	.500	.500
MM	1/8-27	1/4-18	1/4-18	3/8-18	3/8-18	1/2-14
NN	1.375	1.750	2.250	2.750	3.250	4.250
OO	.313	.406	.500	.625	.625	.875
PP	3.594	4.688	4.688	5.688	5.688	7.063
QQ	.688	.875	.875	1.375	1.375	1.438
RR	.375	.500	.500	.625	.625	.750
(RAD.) R	.016	.016	.016	.094	.094	.094
SS	.250	.313	.313	.438	.438	.500
TT	–	.172	–	.438	.438	.438
UU	.969	1.25	1.25	2.00	2.00	2.188
	–	.438	.438	.438	.438	.438
	–	.500	.500	.500	.625	.625

* Double acting with O-ring or low friction packing

** Double acting with U-cup packing

S FF shows total thread, including run out.

Switches (Specifications / Ordering)

Switch

Model Number	119581-1	119581-2	119581-3	119582-1	119582-2	119582-3	119583-1	119583-2	119583-3
Lead Length/Type	1m bare	3m bare	Plug	1m bare	3m bare	Plug	1m bare	3m bare	Plug
Lead Color	Black			Grey			Black		
Switch Type	REED			PNP(SOURCING)			NPN (SINKING)		
Input Voltage	100 VDC, 125 VAC Max.			10 - 30 VDC			5 - 30 VDC		
Operating Current	300mA (150mA Inductive)			7 - 100mA @ 12V			10 - 200mA @ 12V		
	-			14 - 200mA @ 24V			20 - 200mA @ 24V		
Detecting Distance	2.5 mm			1.5 mm			1.5 mm		
Detecting Width	-			3.0 mm			3.0 mm		
Response Time	1 mSec. Min.			-			-		
LED Function	18mA Min.			1mA Min.			1mA Min.		



Switch Mounting Brackets

Bore	Model Number
1-1/8"	119897-18
1-1/2"	119897-15
2"	119897-20
2-1/2"	119897-25
3"	119897-30
4"	119897-40

Note: Order bracket and switch separately.

(Switch Bracket)

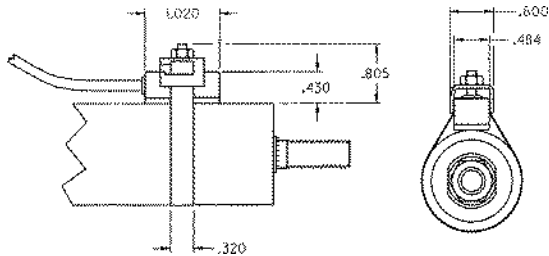

Technical Information:

1. Do not exceed specification, permanent damage to the sensor may occur.
2. For reed switch type sensors, polarity must be observed for the proper functioning of LED. Connect the brown wire in series with load positive (+) and the blue wire to negative (-) or power source space. If the polarity is reversed, reed switch remains functional but LED will remain in "OFF" state.
3. For solid-state type sensors, polarity must also be observed. Connect brown wire to the positive (+) and the blue to the negative (-) of DC power source. The black wire must connect to the load ONLY. If the black wire is accidentally connected to the power source, permanent damage to the sensor may occur.
4. An external protection circuit may be required if the reed switch is used with inductive load, such as relay or solenoid. For DC inductive load, attach an external diode parallel to the load and use R -C circuit parallel with AC inductive load.
5. Keep sensors away from stray magnetic field to prevent malfunctions.
6. When using reed switch with capacitive load or if the lead wire length exceeds 10-meter, and inductor must be installed in series with the sensor to prevent damage (Sticking effect).

SUPPORT BASE