

MHCB..M

Front mounting



MHCB..MZ

Front mounting
(Male thread type)



Features

- Compact body design keeps overall length to a minimum.
- Cylinder barrel internally honed to ensure smooth and consistent piston movement.
- High quality materials are used throughout construction.
- Magnetic as standard.

Specification

Model	MHCB-M
Tube I.D. (mm)	32, 40, 50, 63, 80
The range of stroke (mm)	50
Medium	Filtered oil
Material	Anodised aluminium alloy
Operating pressure range	7 MPa
Ambient temperature	-10~+60°C (No freezing)
Sensor switch	LN32H

Standard stroke

Model	Stroke Tube I.D.	10	20	30	40	50
		MHCB-M	●	●	●	●
	φ 32	●	●	●	●	●
	φ 40	●	●	●	●	●
	φ 50	●	●	●	●	●
	φ 63	●	●	●	●	●
	φ 80	●	●	●	●	●

Order example

MHCB — 50 M — 30 — Z

MODEL

TUBE I.D.

STROKE

M : Magnet

ROD END TYPE



Blank:Female thread



Z:Male thread

Installation of sensor switch

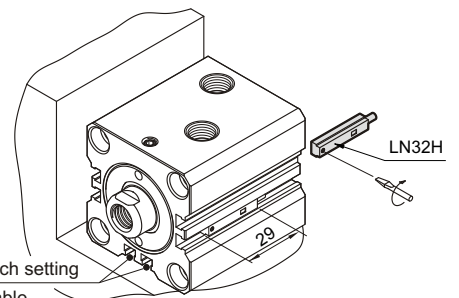

※The sensor switch setting here is not suitable.

○ When setting the sensor switch, it can't be near with magnet materials (carbon steel, cast iron). The distance must be over 10mm. If it is quite near, the sensor switch will be inactive easily.

How to order the seal kit

MHCB-MSK

Tube I.D.	Seal kit
32	MHCB-MSK32 - Including No.6,7,8,9,10
40	MHCB-MSK40 - Including No.6,7,8,9,10
50	MHCB-MSK50 - Including No.6,7,8,9,10
63	MHCB-MSK63 - Including No.6,7,8,9,10
80	MHCB-MSK80 - Including No.6,7,8,9,10

MHCB-M

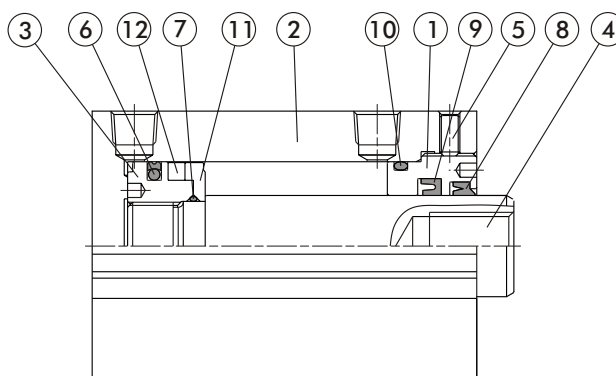

MHCB-MZ

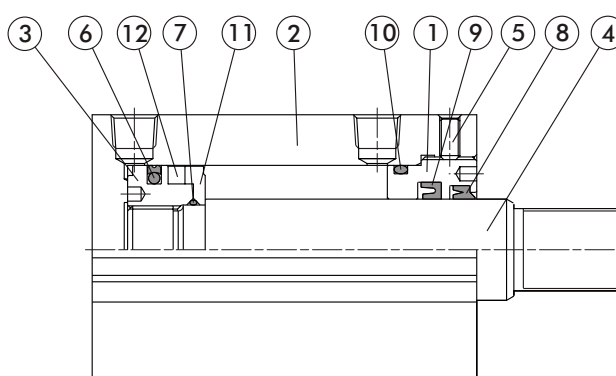

Parts list

No.	Part name	Quantity	No.	Part name	Quantity	No.	Part name	Quantity
1	Rod cover	1	5	Set screw	1	9	Rod packing	1
2	Cylinder tube	1	6	Piston packing	1	10	Cylinder gasket	1
3	Piston	1	7	Piston gasket	1	11	Washer	1
4	Piston rod	1	8	Dust wiper	1	12	Magnet	1

MHCB-M Dimensions $\phi 32 \sim \phi 80$



COMPACT HYDRAULIC WITH PISTON SENSING CYLINDERS

mindman

MHCB-M

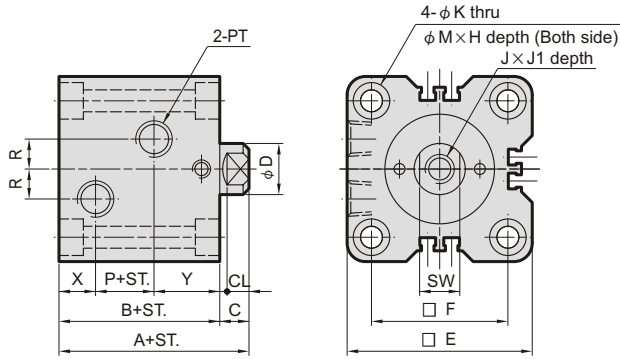

MHCB-MZ

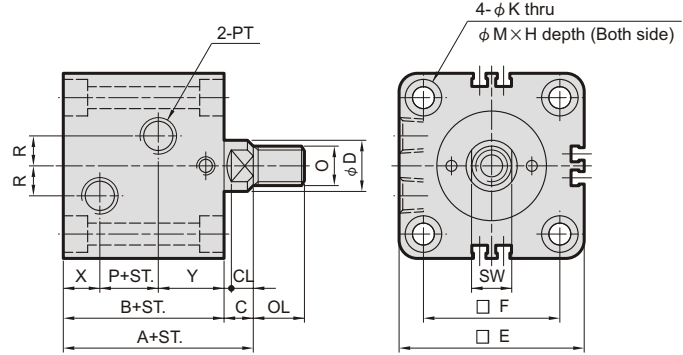
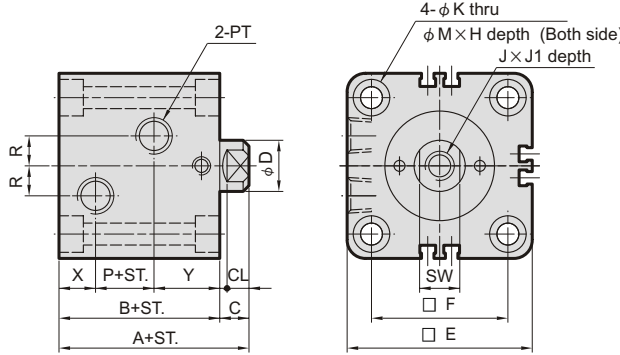
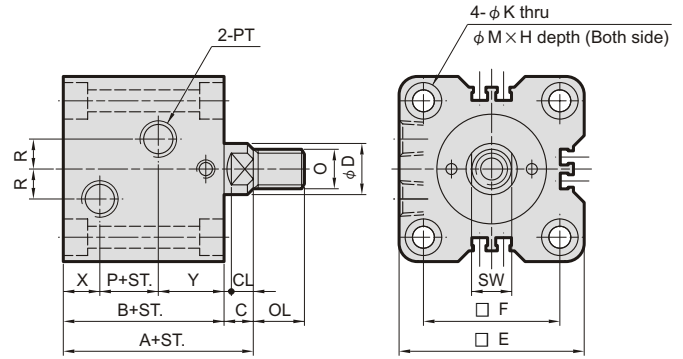

ST.=stroke

Code Tube I.D.	C	CL	F	D	E	H	J	J1	K	M	O	OL	PT	R	SW	X	Y
$\phi 32$	10	7	47	20	62	6.5	M12×1.75	15	6.6	11	M16×1.5	25	Rc1/4	10	17	12	28
$\phi 40$	10	7	52	25	70	9	M16×2.0	20	9	14	M22×1.5	30	Rc1/4	10	22	12	28
$\phi 50$	11	8	58	30	80	11	M20×2.5	25	11	18	M26×1.5	35	Rc1/4	10	27	12.5	29.5
$\phi 63$	13	10	69	35	94	13	M27×3.0	35	13	20	M30×1.5	40	Rc3/8	10	32	16	31
$\phi 80$	17	14	86	45	114	15	M30×3.5	35	15	22	M39×1.5	45	Rc3/8	15	41	18	33

Tube I.D. (mm)		Stroke									
		5	10	15	20	25	30	35	40	45	50
$\phi 32$	A	74	74	84	84	94	94	104	104	114	114
	B	64	64	74	74	84	84	94	94	104	104
	P	24	24	34	34	44	44	54	54	64	64
$\phi 40$	A	75	75	85	85	95	95	105	105	115	115
	B	65	65	75	75	85	85	95	95	105	105
	P	25	25	35	35	45	45	55	55	65	65
$\phi 50$	A	81	81	91	91	101	101	111	111	121	121
	B	70	70	80	80	90	90	100	100	110	110
	P	28	28	38	38	48	48	58	58	68	68
$\phi 63$	A	90	90	100	100	110	110	120	120	130	130
	B	77	77	87	87	97	97	107	107	117	117
	P	30	30	40	40	50	50	60	60	70	70
$\phi 80$	A	105	105	115	115	125	125	135	135	145	145
	B	88	88	98	98	108	108	118	118	128	128
	P	37	37	47	47	57	57	67	67	77	77



mindman