



## ***Series RT Hydraulic Rotating Cylinders***

- Continuous 500 RPM Capability
- 1,500 PSI Pressure Rating
- Flush and Flange Mountings
- Exclusive Coupling Sealing System
- Nitrotec-Hardened Coupling Housing and Stem
- 4.5" – 16.00" Standard Bore Sizes

## Series RT Heavy-Duty Hydraulic Rotating Cylinders

Hanna's rugged, heavy-duty hydraulic rotating cylinders provide optimum performance wherever rotation and linear actuation interface. Applications include recoilers, uncoilers, tension reels, transfer line spindles, and power chucking on machine tools.

The coupling is supported by two anti-friction bearings, enabling the cylinder to maintain 500 RPM. Mirror-finished, Nitrotec-treated coupling housing and Nitrotec-treated stem provide extra-hardened surfaces for longer seal life, and corrosion protection with high water based fluids.

In addition to the axial support and stability of the coupling, the large diameter permits the use of either a probe indicator to actuate travel limit devices; or Hanna's optional Electronic Feedback device for the ultimate in safety and product yield. The design latitude thus offered expands the inherent capabilities of Series RT rotating cylinders.

Available flush or flange mounted, Hanna's Series RT cylinders offer hydraulic p.s.i. ratings up to 1500. Standard bore sizes are 4.50" through 16.00". Hanna can also meet special requirements for larger bore sizes, higher RPM or greater pressures. Please consult the factory.

### HYDRAULIC PRESSURE AND RPM LIMITS

BORE SIZE	20 GPM COUPLING		45 GPM COUPLING	
	P.S.I.	R.P.M.	P.S.I.	R.P.M.
4.50	1500	500	—	—
6.00	1500	500	—	—
8.00	1500	500	1500	350
10.00	1500	500	1500	350
12.00	1500	500	1500	350
14.00	1000	500	1000	350
16.00	1000	500	1000	350

### CONTENTS

How to Order.....	232
Series RT Cylinder Features.....	222
Series RT Coupling Features.....	223
MF3 Flange Mounted Cylinder Dimensions .....	224
MR2 Flush Mounted Cylinder Dimensions .....	225
Options.....	226
Tell-Tale Sensor .....	227
Pressure, Force and Volume Data.....	228
Installation and Maintenance Data, Fastener Torques.....	229
Parts List .....	230
Cylinder Weights .....	230
Seal Kits .....	231

## Series RT Hydraulic Rotating Cylinders

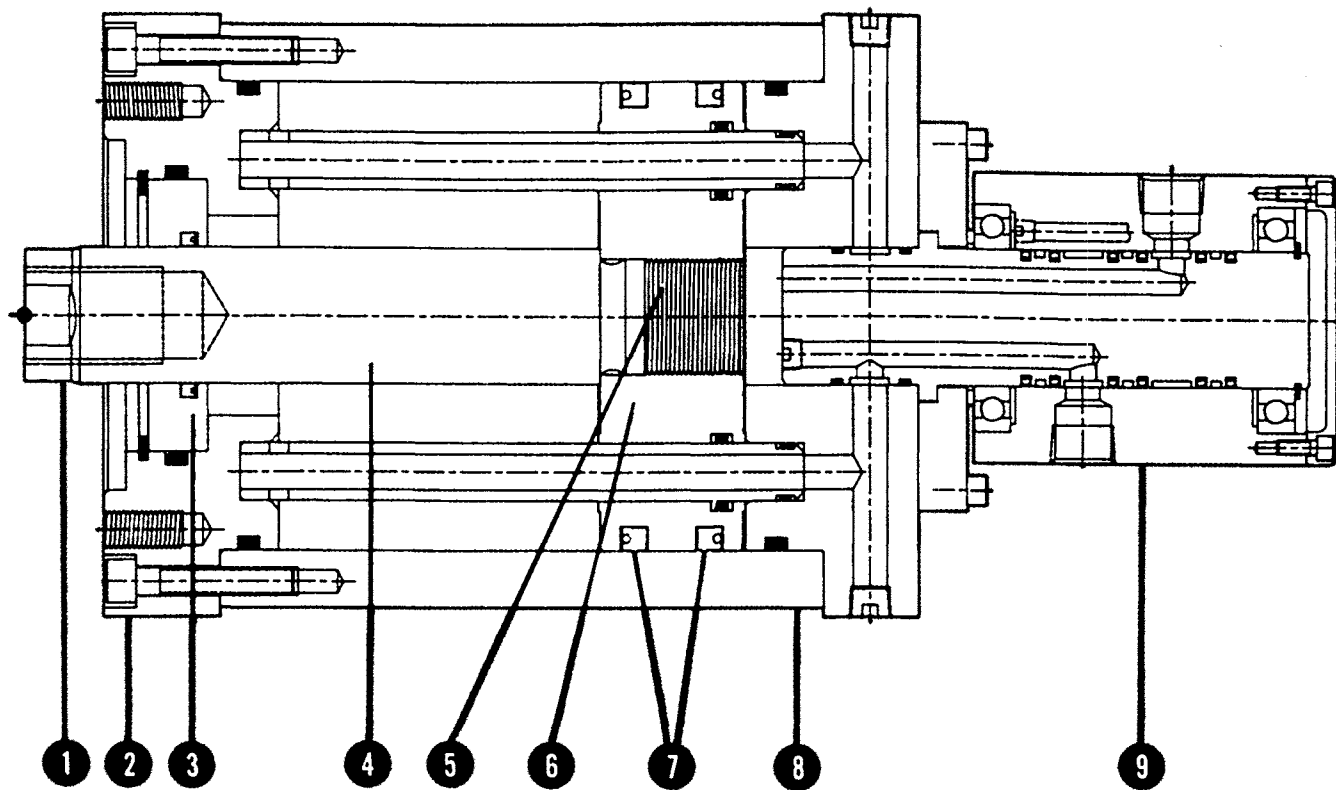

### Series RT Cylinder Features

#### 1. Piston Rod End

Integral thread construction, precision-machined for close concentricity.

#### 2. Heads

Steel heads are precision-machined to assure accurate alignment and close concentricity between piston, tube, piston rod and rod bearing.

#### 3. Rod Bearing Cartridge

Tapped for quick and easy removal.

#### 4. Piston Rod

Hanna's piston rods are machined to a close tolerance with minimum stock removal to maximize shank size and reduce stress. Relief grooves are machined in areas of high stress to guard against fatigue failures. All rod sizes are hard chrome plated for scratch and corrosion resistance. To maximize seal and bearing life, plated surface is polished to an 8-micro-inch finish.

#### 5. Piston-to-Rod Connection

Piston rods are piloted to the piston to ensure concentricity, then bonded by an anaerobic adhesive, torqued and pinned.

#### 6. Piston

One-piece piston is made of high impact ductile iron, threaded to the piston rod.

#### 7. Piston Sealing System

Self-regulating, wear-compensating, pressure-energized polyurethane seal assures zero by-pass. For higher temperature service, or for use with fire-resistant or high water-based fluids, Viton seals are an available option.

#### 8. Tubing

Steel tubing is precision-honed to a 16 micro-inch finish for close tolerance between piston seal and tube wall, thus extending seal life.

#### 9. Coupling

Series RT standard 20 GPM coupling is rated at 500 RPM. Optional 45 GPM coupling with a 350 RPM rating is available for cylinders with 8.00" and larger bore sizes. Both couplings bolt on, and are easily removed from the outside.

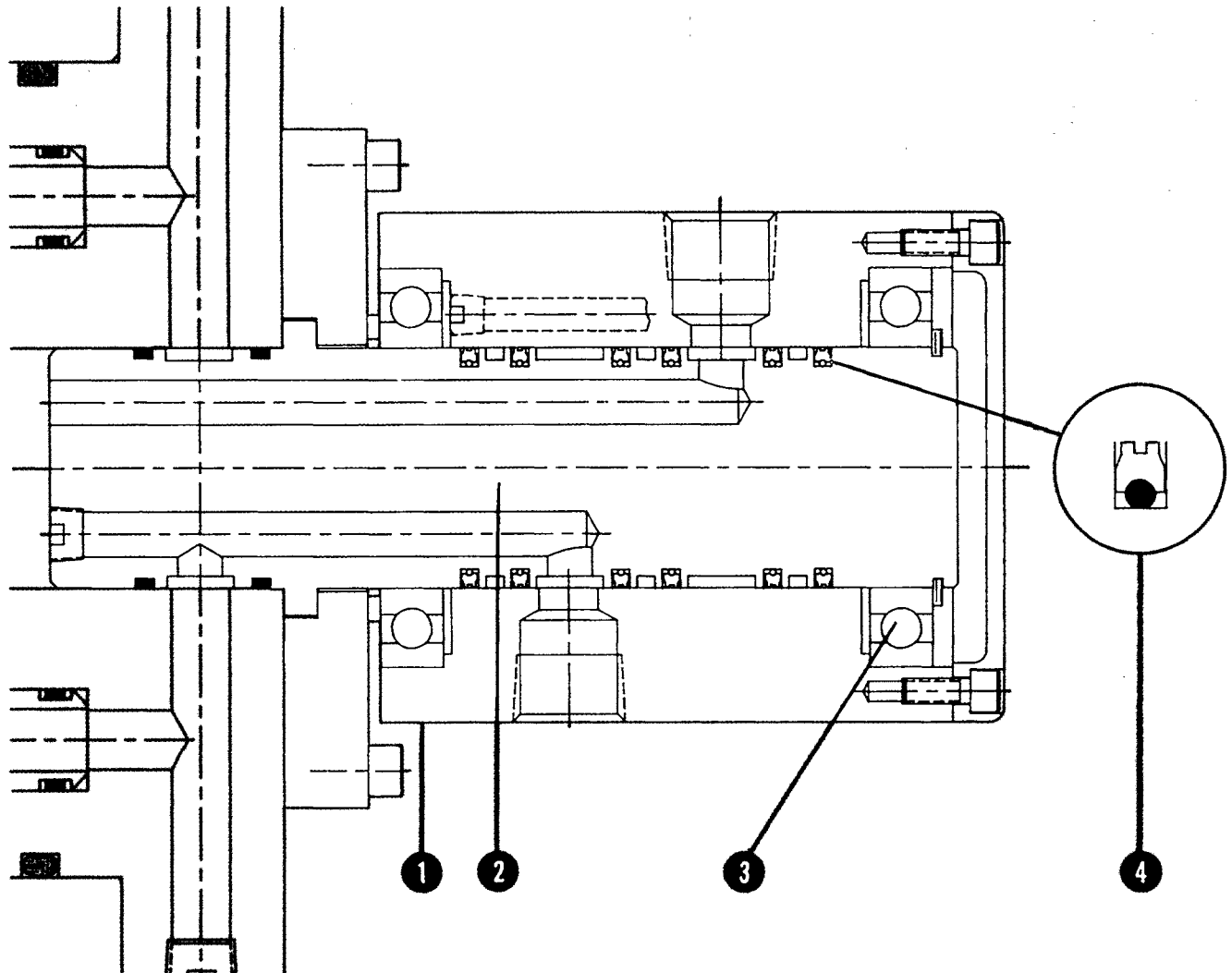

## Series RT Coupling Features

### 1. Nitrotec-Treated Coupling Housing

Nitrotec treatment of Series RT coupling housings provides specific characteristics that enhance cylinder performance and assure long service life. An advanced heat treating method, the Nitrotec process converts the first few thousandths of an inch of the housing's interior surface depth to an iron nitride, non-metallic layer, which has a hardness of approximately 60 Rc. In the process, the surface also becomes microporous.

This extremely hard microporous surface layer enables the coupling housing to exhibit three important engineering characteristics:

- (1) Wear resistance superior to conventional heat treatment.
- (2) Oil retention for operating lubricity comparable to non-ferrous sintered bearings.
- (3) Excellent corrosion resistance.

Prior to the Nitrotec treatment, the interior surface layer is precision honed for exacting size control. The combination of the Nitrotec process and the precision honing provides the optimum surface for extended seal life, and corrosion resistance when high water based fluids are used.

### 2. Nitrotec-Treated Coupling Stem

As is the case with the housing, the coupling stem is also hardened via the Nitrotec process, assuring long life and maximum corrosion protection.

### 3. Dual Bearing Coupling Construction

Each end of the coupling housing is supported on the stem by a permanently-lubricated, anti-friction, factory-sealed bearing. The dual bearing construction makes the entire unit extra rugged, assuring rigidity and stability under the most difficult operating conditions. This rigidity and stability further extend seal life.

### 4. Exclusive Coupling Sealing System

Hanna's exclusive mechanically-energized, carbon-graphite filled Teflon coupling seals provide maximum sealing efficiency. Engineered specifically for high RPM applications, they minimize friction, thereby eliminating the heat build-up that causes excessive wear in a rotating cylinder coupling. The result: long service life! The seals are compatible with most all hydraulic fluids, including fire resistant and high water based fluids.

# MF3 Flange Mount

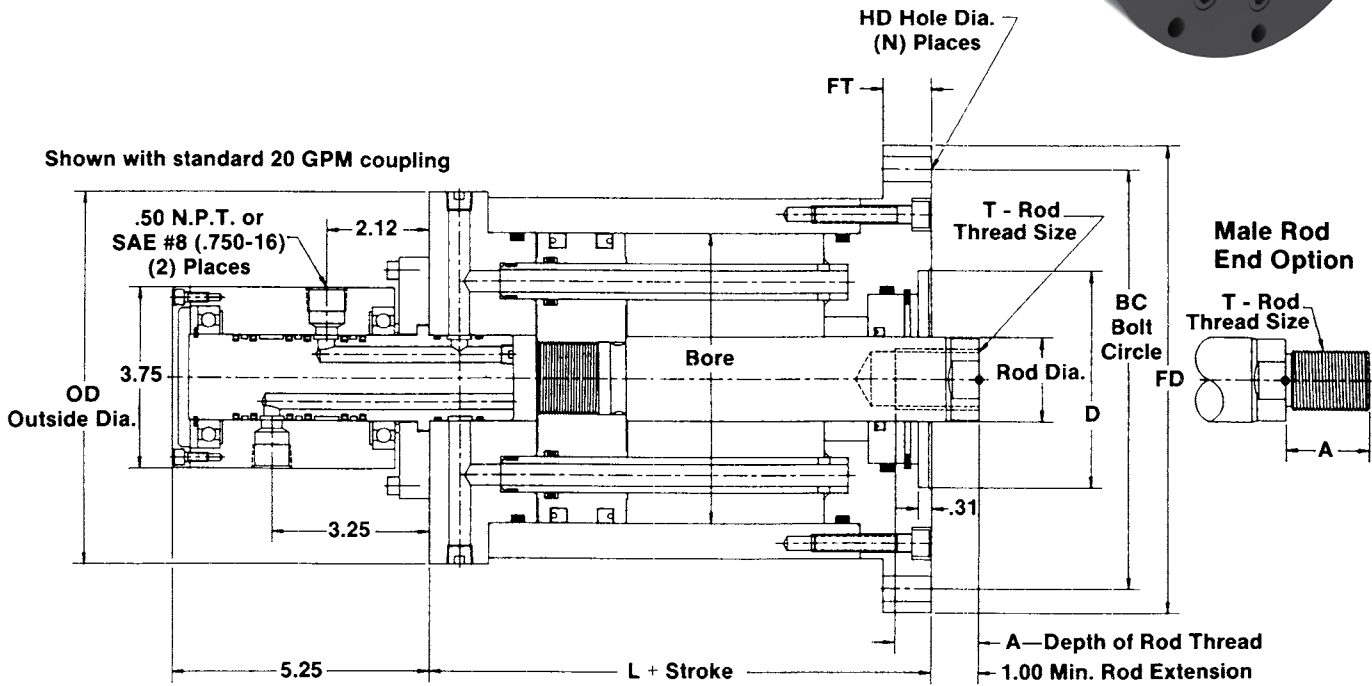
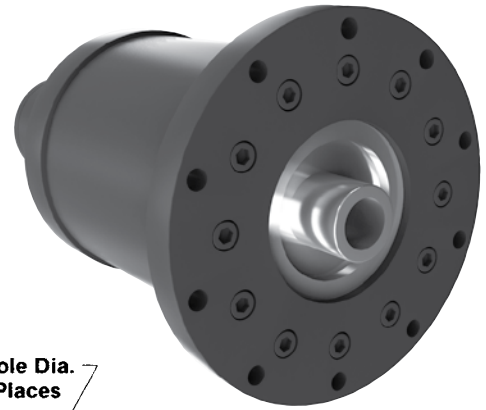

**NOTE:** .25 NPT (or #4 [.438-20] SAE) coupling drain port not shown. Must be piped back unrestricted.

## DIMENSIONS

CYLINDER			A	D +.001 -.000	L	T (THREAD)		OD	BC	N	HD	FD	FT
BORE	ROD DIA. CODE	ROD DIA.				SMALL MALE SM	SHORT FEMALE SF						
4.50	I	1.25	1.25	3.000	5.69	88-14	88-14	6.12	7.00	5	53	8.00	1.00
	H	1.75	1.75	4.002	5.69	1.25-12	1.25-12	6.12	7.00	5	53	8.00	1.00
6.00	H	1.75	1.75	4.500	6.31	1.25-12	1.25-12	7.75	8.75	8	53	9.75	1.00
	K	2.50	2.50	5.502	6.31	1.88-12	1.88-12	7.75	8.75	8	53	9.75	1.00
8.00	J	2.00	2.00	5.000	6.56	1.50-12	1.50-12	9.88	11.50	6	78	13.12	1.25
	L	3.00	3.00	6.002	6.56	2.25-12	2.25-12	9.88	11.50	6	78	13.12	1.25
10.00	K	2.50	2.50	6.000	6.68	1.75-12	1.75-12	11.88	13.50	10	78	15.62	1.38
	M	3.50	3.50	8.002	6.68	2.50-12	2.50-12	11.88	13.50	10	78	15.62	1.38
12.00	M	3.50	3.50	7.500	6.94	2.00-12	2.00-12	14.19	16.25	10	91	18.00	1.50
	P	4.50	4.50	10.002	6.94	3.00-12	3.00-12	14.19	16.25	10	91	18.00	1.50
14.00	N	4.00	4.00	9.000	7.69	2.50-12	2.50-12	16.25	18.25	12	91	20.00	1.50
	R	5.00	5.00	10.002	7.69	3.50-12	3.50-12	16.25	18.25	12	91	20.00	1.50
16.00	N	4.00	4.00	10.000	10.00	2.50-12	2.50-12	18.62	20.88	12	106	23.00	1.50
	R	5.00	5.00	10.002	10.00	3.50-12	3.50-12	18.62	20.88	12	106	23.00	1.50

# MR2 Flush Mount

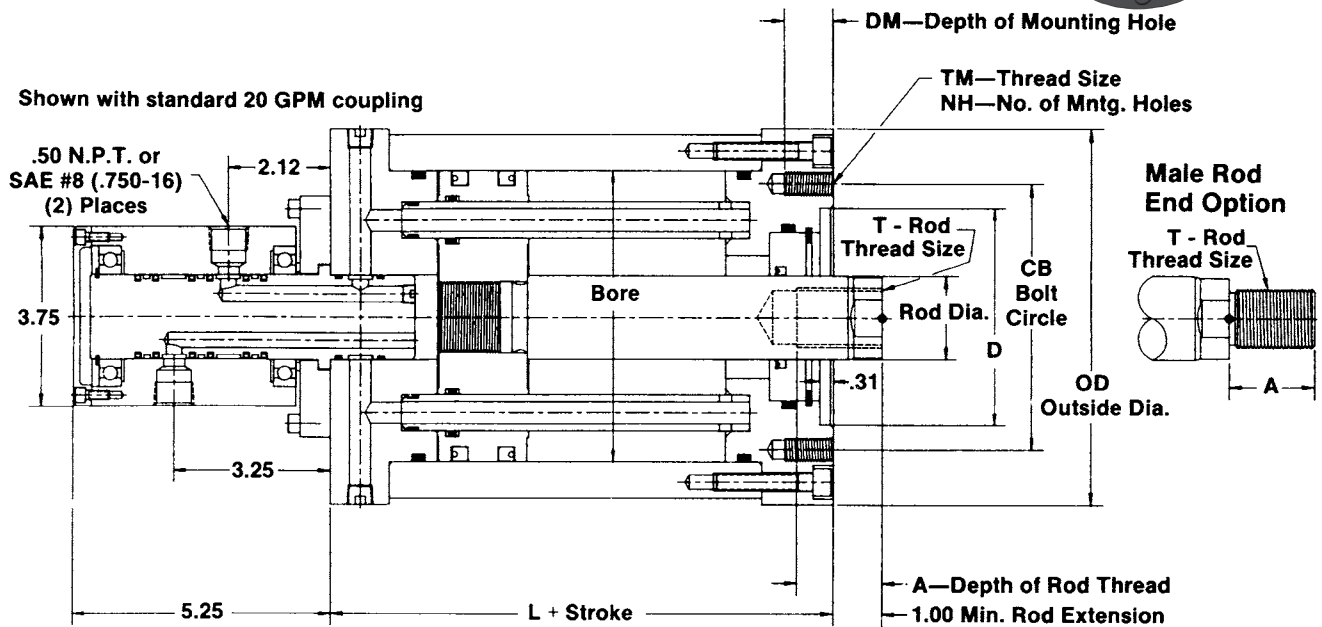

**NOTE:** .25 NPT (or #4 [.438-20] SAE) coupling drain port not shown. Must be piped back unrestricted.

## DIMENSIONS

CYLINDER			A	D +.001 -.000	L	T (THREAD)		OD	CB	DM	NH	TM
BORE	ROD DIA. CODE	ROD DIA.				SMALL MALE SM	SHORT FEMALE SF					
4.50	I	1.25	1.25	3.000	5.69	88-14	88-14	6.12	3.75	1.00	4	50-13
	H	1.75	1.75	4.002	5.69	1.25-12	1.25-12	6.12	5.00	.75	5	50-13
6.00	H	1.75	1.75	4.500	6.31	1.25-12	1.25-12	7.75	5.50	1.00	8	50-13
	K	2.50	2.50	5.502	6.31	1.88-12	1.88-12	7.75	6.50	.75	8	50-13
8.00	J	2.00	2.00	5.000	6.56	1.50-12	1.50-12	9.88	6.50	1.00	8	62-11
	L	3.00	3.00	6.002	6.56	2.25-12	2.25-12	9.88	8.00	1.00	6	75-10
10.00	K	2.50	2.50	6.000	6.68	1.75-12	1.75-12	11.88	8.50	1.12	8	75-10
	M	3.50	3.50	8.002	6.68	2.50-12	2.50-12	11.88	9.50	1.00	10	75-10
12.00	M	3.50	3.50	7.500	6.94	2.00-12	2.00-12	14.19	10.50	1.25	10	75-10
	P	4.50	4.50	10.002	6.94	3.00-12	3.00-12	14.19	11.50	1.12	10	88-9
14.00	N	4.00	4.00	9.000	7.69	2.50-12	2.50-12	16.25	12.50	1.25	15	75-10
	R	5.00	5.00	10.002	7.69	3.50-12	3.50-12	16.25	12.00	1.12	12	88-9
16.00	N	4.00	4.00	10.000	10.00	2.50-12	2.50-12	18.62	14.50	2.00	16	1.25-7
	R	5.00	5.00	10.002	10.00	3.50-12	3.50-12	18.62	13.00	1.50	12	1.00-8

## 45 GPM Coupling

Hanna offers a 45 GPM coupling as an option for Series RT rotating cylinders with 8.00" and larger bore sizes.

The unit has a 45 GPM flow rate at 15 feet per second velocity, and 350 RPM. Maximum hydraulic pressure rating is 1500 P.S.I. Higher pressures and RPM are available as specials. Please consult the factory. Tell-tale sensor and Electronic Feedback device options are also available. See Page 227.

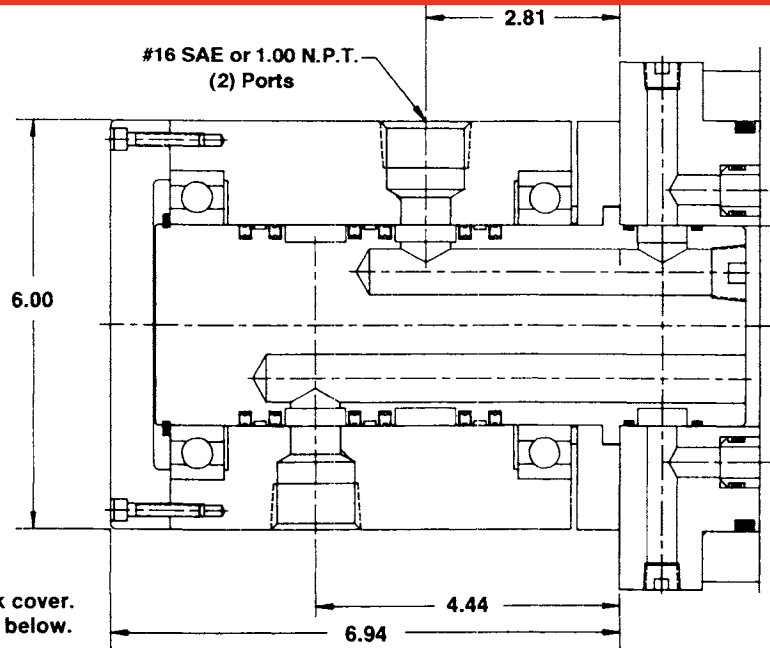

Shown with standard back cover.  
Slotted back cover shown below.

## SAE 4-Bolt Flange Ports

COUPLING SIZE	PORT DIA.	GG	X	Q	W	AA	Z	B
20 GPM	50	69	34	1 50	75	50	312-18	1 25
	75	88	44	1 88	94	50	375-16	1 06
45 GPM	1.00	1 03	52	2 06	1 03	56	375-16	1 25
	1 25	1 19	59	2 31	1 16	62	438-14	1 44

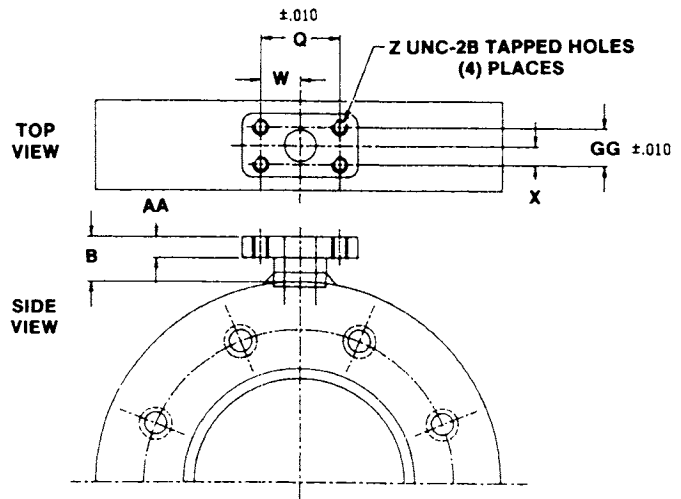

## Slotted Coupling Back Covers

Both 20 GPM and 45 GPM couplings are available with a slotted back plate to accommodate a stabilizer bar.

20 GPM Coupling Back Cover

45 GPM Coupling Back Cover

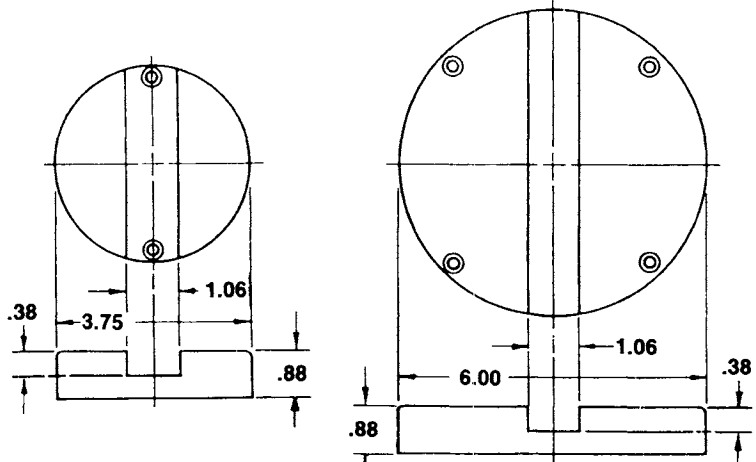

# TELL-TALE SENSOR

This mechanical position indicator is an option available on both 20 GPM and 45 GPM couplings.

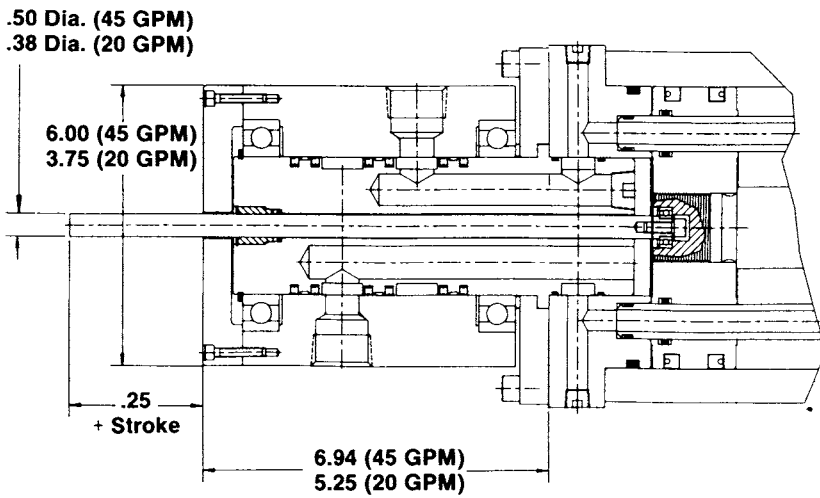

Rotating Cylinder with Tell-Tale Sensor

Switch Bracket Mtg. Holes

10-24 NC,  
4 Holes,  
.38 Deep

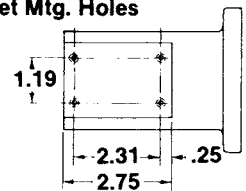

Tell-Tale Sensor

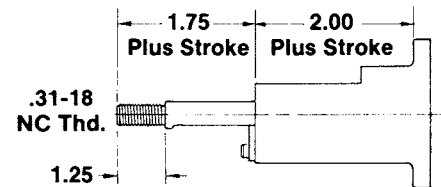

Non-Rotating Tell-Tale Sensor

Note: Trip rod end configurations other than shown will be quoted on request.

## Electronic Feedback Device

Series RT Rotating Cylinders with the 45 GPM coupling are available equipped with Hanna's Electronic Feedback device. With this unit, precise size control can be maintained on the mandrel of a recoiling or uncoiling machine,

thus providing an additional safety factor, as well as increased product yield. The Electronic Feedback device provides positional accuracy of  $\pm .001$  in digital systems; analog responses on positions less than .010 are common.

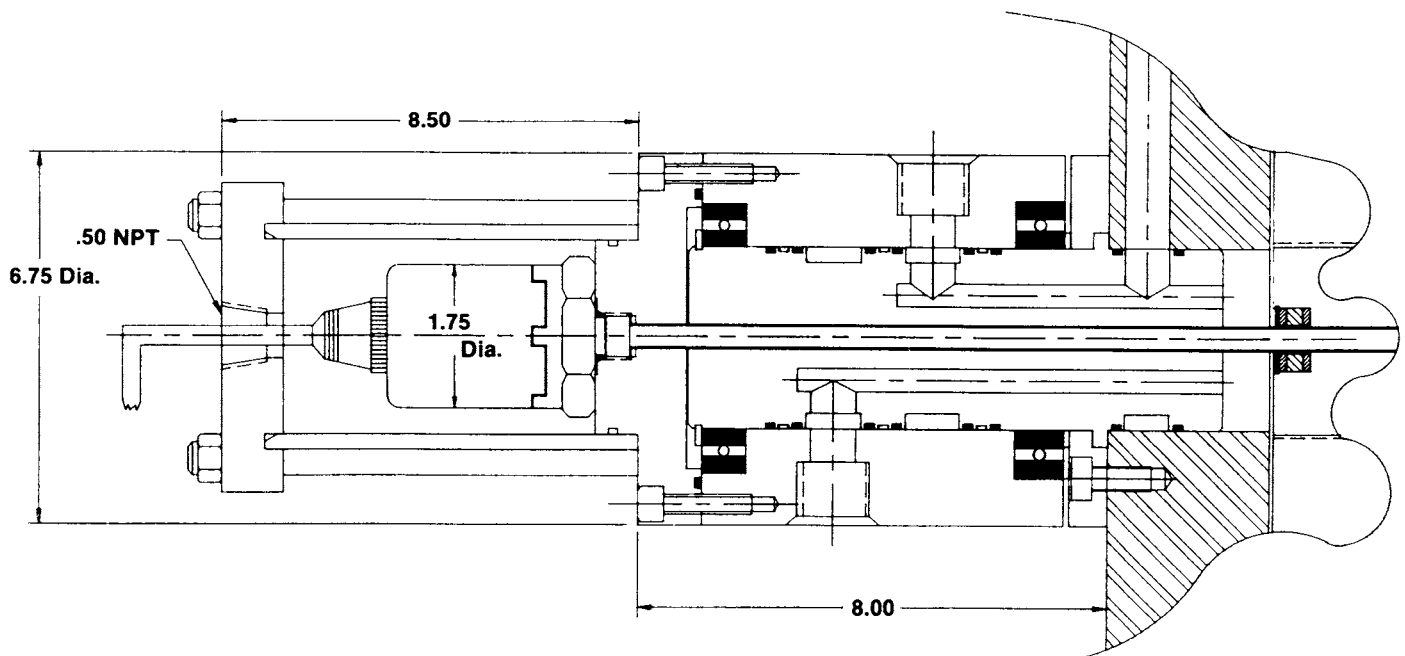

# PRESSURE, FORCE AND VOLUME DATA

## CYLINDER THRUST FORCE

Cylinder Thrust Force in Pounds for Various Line Pressures								Consumption Per Inch of Stroke in One Direction		
Cylinder Bore Inches	Piston Area Sq. In.	Pressures of Operating Medium—Air or Hydraulic						Oil* Gallons Displaced	Pressure Air Cubic Ft Displaced	Free Air Cubic Ft at 80 PSI
		50 PSI	80 PSI	100 PSI	250 PSI	500 PSI	1,000 PSI			
4.50	15.904	795	1,272	1,590	3,976	7,952	15,904	0688	0092	0593
6.00	28.274	1,414	2,262	2,827	7,071	14,137	28,274	1224	0164	1056
8.00	50.265	2,513	4,021	5,027	12,566	25,133	50,265	2176	0291	1873
10.00	78.540	3,927	6,283	7,854	19,635	39,270	78,540	3400	0455	2928
12.00	113.100	5,655	9,048	11,310	28,275	56,550	113,100	4896	0656	4226
14.00	153.940	7,697	12,315	15,394	38,485	76,970	153,940	6664	0891	5740
16.00	201.060	10,053	16,085	20,106	50,265	100,530	201,060	8704	1163	7492

\*GPM = gallons per inch times inches per minute

## ROD DIAMETER THRUST FORCE

Rod Diameter Thrust Force in Pounds for Various Line Pressures								Consumption Per Inch of Stroke in One Direction		
Piston Rod Bore Inches	Piston Area Sq. In.	Pressures of Operating Medium—Air or Hydraulic						Oil* Gallons Displaced	Pressure Air Cubic Ft Displaced	Free Air Cubic Ft at 80 PSI
		50 PSI	80 PSI	100 PSI	250 PSI	500 PSI	1,000 PSI			
1.25	1.227	61	98	122	306	610	1,227	0053	0007	0043
1.75	2.405	120	192	241	601	1,203	2,405	0104	0014	0090
2.00	3.142	157	251	314	786	1,571	3,142	0136	0019	0122
2.50	4.909	245	392	491	1,225	2,450	4,900	0213	0021	0183
3.00	7.069	353	566	707	1,767	3,535	7,069	0306	0041	0264
3.50	9.621	481	770	962	2,405	4,811	9,621	0417	0056	0358
4.00	12.566	628	1,005	1,257	3,142	6,283	12,566	0544	0073	0468
4.25	14.186	709	1,134	1,418	3,546	7,093	14,186	0614	0082	0508
4.50	15.904	795	1,272	1,590	3,976	7,952	15,904	0688	0092	0593
5.00	19.635	982	1,571	1,964	4,909	9,818	19,635	0850	0114	0732
5.50	23.758	1,188	1,901	2,376	5,940	11,879	23,758	1028	0137	0861

## OIL FLOW

S = Standard weight pipe. X = Extra strong. XX = Double extra strong. <b>Butt Welded Steel Clean Pipe</b>				Oil Flow in Gallons Per Minute and Friction Pressure Drop in Pounds Per Square Inch Per Foot Length of Pipe						Equivalent Length of Straight Pipe in Feet for Various Fittings		
Pipe Size	Bursting Pressure PSI	Internal Diameter Inches	Internal Area Sq. In.	Velocity = 10 Ft Per Sec		Velocity = 20 Ft Per Sec		Velocity = 30 Ft Per Sec		Pipe Size	Elbow	Tee
				Gals Per Minute	Pressure Drop in PSI	Gals Per Minute	Pressure Drop in PSI	Gals Per Minute	Pressure Drop in PSI			
3/8S	10,754	.493	.191	5.98	1.19	11.96	3.71	17.94	7.31	3/8	1.3	3.0
1/2S	10,784	.622	.304	9.48	.82	18.96	2.75	28.44	5.36	1/2	1.5	3.3
3/4X	11,728	.742	.433	13.52	.69	27.04	2.15	40.56	4.15			
3/4S	8,608	.824	.533	16.78	.59	33.56	1.80	50.34	3.44	3/4	2.2	4.6
1-1/4XX	18,408	.896	.630	19.66	.54	39.32	1.64	58.98	3.13			
1X	10,888	.957	.719	22.42	.49	44.84	1.54	67.26	2.93			
1S	8,088	1.049	.864	27.18	.43	54.36	1.40	81.54	2.67	1	2.8	5.7
1-1/2XX	16,840	1.100	.950	29.62	.41	59.24	1.34	88.86	2.44			
1-1/4X	9,200	1.278	1.283	40.30	.33	80.60	1.07	120.90	2.00			
1-1/4S	6,744	1.380	1.495	46.96	.31	93.92	.91	140.88	1.76	1-1/4	3.7	7.8

(P λ) = Pressure drops have been derived from the rational formula —  $P \lambda = \frac{323 f S L V^2}{d}$

(G P M) = Gallons per minute have been derived from the rational formula —  $G = 431 \sqrt{\frac{P \lambda d^5}{f S L}}$

(f) = Friction factors from "Piping Handbook," 4th Ed., Fig. 15a  $\frac{d v s}{Z}$

# INSTALLATION AND MAINTENANCE DATA

## STORAGE:

Cylinders in storage should always be fully protected against the elements or other adverse conditions.

## INSTALLATION:

The pipe ports of cylinders are sealed with plastic plugs. The plugs protect the precision internal parts by sealing out damaging dirt and grit. Do not remove port seals until ready to connect piping. To protect cylinders, clean all pipes and pipe fittings of dirt, scale, and thread chips. A filter is recommended to keep the operating fluid free of foreign matter.

Accurate mounting and alignment are essential to proper cylinder performance. By eliminating side loading, packing and bearing life will be increased.

## MAINTENANCE:

Precision construction of Hanna cylinders minimizes wear as a maintenance problem. Parts which may need replacement in the course of normal use are the packings for the piston and piston rod, guide pin seals and coupling seals.

**To replace rod seal**, remove front head from tube. Remove gland retaining ring and push the gland out from tube end. Remove old rod seal and gland O-ring, and carefully clean both grooves. To reassemble, slip new rod packing into groove, exercising care not to nick the lips of the packing. Install gland and retaining ring, then replace front head and retorque per the **Fastener Torque** table as shown on this page.

**To replace piston seals and guide pin O-rings**, remove front head and piston rod assembly. Remove old packings and carefully clean grooves. Install new seals. Place guide pins into back head. Carefully replace ram assembly into tube, lining up guide pins. Exercise care not to damage packing lips. Replace front head, and retorque per the **Fastener Torque** table.

**To replace coupling seals**, remove coupling cap and bearing retaining ring. Remove coupling housing, then remove retainer cap screws. Slide coupling shaft out of back head, and remove old seals. Clean all grooves and replace shaft O-rings. Then replace shaft into back head, and secure with retainer and cap screws. Retorque per **Fastener Torque** table.

**For cylinders with old style seals**, replace O-rings and back-up washers, then replace housing, retaining ring and coupling cap. Torque per **Fastener Torque** table.

**For cylinders with new style seals (Roto Seals)**, slide (1) O-ring into O-ring groove closest to back head, then pre-form the seal by stretching it slightly. Position seal over O-ring, and with your fingers, resize the seal into the groove. For final re-sizing, slide coupling housing over the seal, using care not to nick the seal. Repeat this procedure for all the remaining seals. Finally, replace housing and bearing retainer, coupling cap and cap screws. Retorque per **Fastener Torque** table.

## Roto-Seal Installation Tools

Hanna offers installation tools which significantly facilitate and simplify the replacement procedure for coupling Roto-Seals. For further information, contact your Hanna distributor.



20 GPM Coupling – Part No. R1756A    Part No. R1755A  
45 GPM Coupling – Part No. R1801A    Part No. R1800A

## FASTENER TORQUES

BORE	PARTS LIST ITEM #30 CAP SCREW		PARTS LIST ITEM #9 RETAINER SCREW		PARTS LIST ITEM #2 COUPLING CAP SCREW	
	SIZE	TORQUE	SIZE	TORQUE	SIZE	TORQUE
4.50	50-13	80 ft.-lbs	38-16	34 ft.-lbs	#10-24	4 ft.-lbs
6.00	50-13	80	38-16	34	#10-24	4
8.00	50-13	80	38-16	34	#10-24	4
10.00	62-11	150	38-16	34	#10-24	4
12.00	62-11	150	38-16	34	#10-24	4
14.00	62-11	150	38-16	34	#10-24	4
16.00	62-11	150	38-16	34	#10-24	4

**Note:** Replacement parts can be furnished quickly if you will indicate the serial number of the cylinder as shown on the name plate, and the part name and number, as shown on Pages 12 and 13. The cylinder illustrated is for reference purposes only, and does not represent any particular model.

# PARTS LIST

When ordering replacement parts, identify  
Model Number, Serial Number and  
Part Number as shown below.

Part No.	No. Req'd.	Description
1	1	Coupling Cap
2	2	Coupling Cap Screw
3	1	Retaining Ring
4	2	Bearing
5*	6	Roto Seal
6	1	Coupling Shaft
7	1	Coupling Housing
8	1	Spacer
9	4	Retainer Screw
10	1	Coupling Retainer
11*	2	O-Ring (Shaft)
12	1	Back Head
13	2	Port Plug
14	2	Port Plug
15*	4	Back-up Washer
16*	2	O-Ring (Guide Pin)
17*	2	O-Ring (Tube)
18*	2	O-Ring (Piston Guide)
19*	4	Back-up Washer
20	2	Guide Ring
21*	2	Piston Packing
22	1	Piston
23	1	Tube
24	1	Piston Rod
25*	1	Rod Packing
26	1	Rod Bearing
27*	1	O-Ring (Bearing)
28	1	Retaining Ring
29	1	Front Head
30	**	Cap Screw
31	1	Port Plug

\*Recommended spare parts

\*\*As required

## CYLINDER WEIGHTS

BORE	ROD CODE	BASE WT. AT ZERO STROKE	WT. PER INCH OF STROKE	COUPLER	
				20 GPM	45 GPM
4 50	I H	46 lbs	3 85 4 20	16 lbs. All Units	55 lbs. All Units
6 00	H K	85	6 00 6 75		
8 00	J L	145	7 80 8 90		
10 00	K M	215	9 90 11 25		
12 00	M P	345	14 30 16 10		
14 00	N R	460	18 75 20 80		
16 00	N R	780	28 00 31 33		

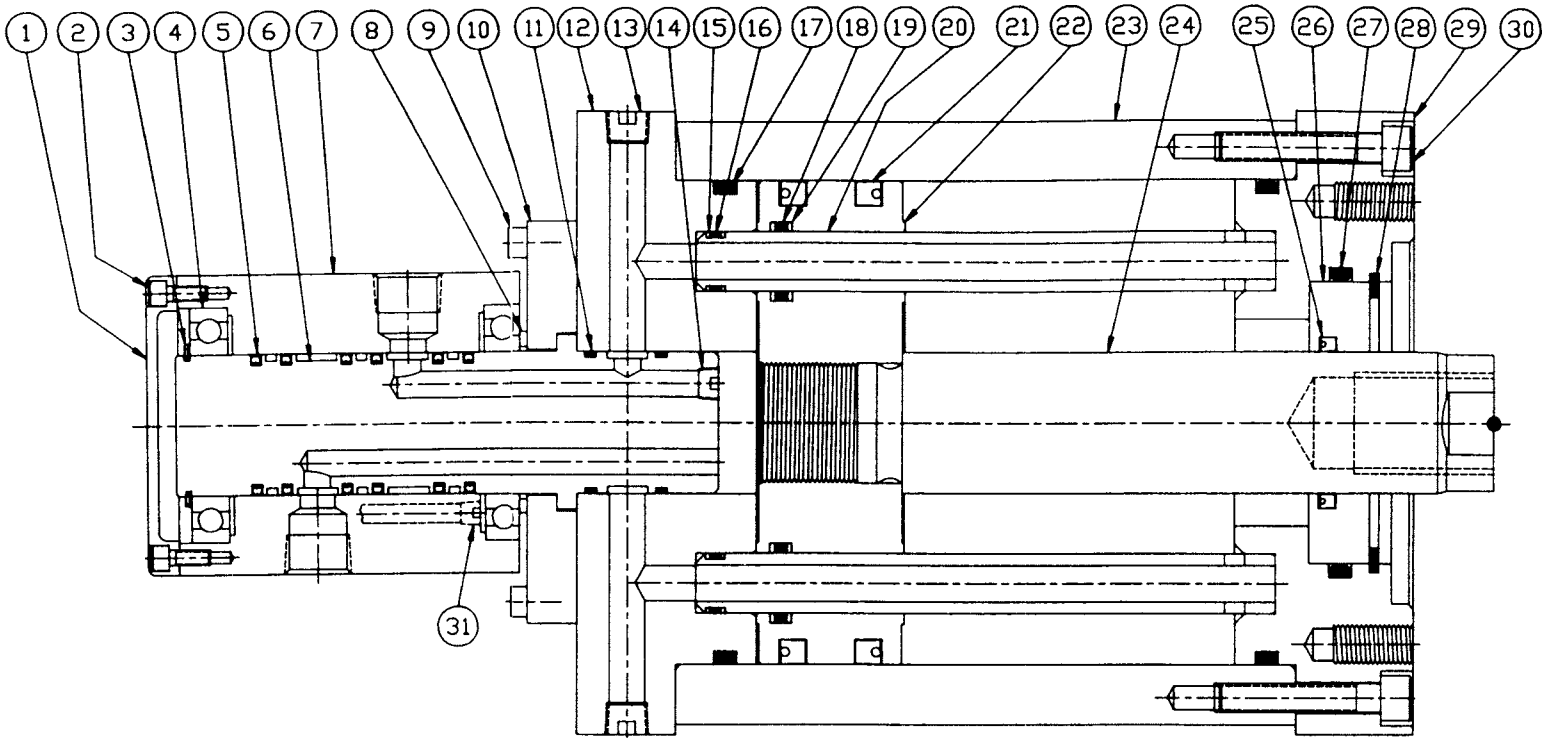

## SEAL KITS

### PISTON ROD KITS

Ordering Example  
SEAL KIT **H-2**

From  From  
piston rod code rod packing code

Order by Piston Rod Packing Code and Rod Diameter Code from nameplate as outlined:

- 2** — Standard  
Polyurethane Packing with Buna-N O-Ring Expander, Buna-N O-Ring
- 3** — Optional  
Viton Packing, Viton O-Ring

### PISTON PACKING KITS

Ordering Example  
SEAL KIT **A-4.50**

From  Bore Size  
piston packing code

Order by Piston Packing Code and Bore Size from nameplate as outlined:

- A** — Standard  
Polyurethane Packings with Buna-N O-Ring Expander, Buna-N Tube Seals
- B** — Optional  
Viton Packings with Teflon Back-Ups, Viton Tube Seals

### COUPLING SEAL KITS

Includes 6 carbon-graphite filled Teflon Roto Rings with 6 Viton Expander O-Rings and 2 Viton O-Rings.

**Specify 20 or 45 GPM Coupling.**

# HOW TO ORDER

