

# Pneumatic Cylinders

## Micro-Air

### Features

#### Series 01

Micro-Air Cylinders are ideal for small part positioning, clamping and ejecting. Also they're the perfect choice for applications where small bore, medium duty, repairable cylinders are preferred. Prelubed, they're suitable for operations without externally applied lubrication.

- Micro-Air Cylinders are repairable. Service kits are available to extend the useable life of the cylinder.
- Micro-Air Cylinders operate on air pressure to 200 p.s.i. (14 bar). A tough little cylinder that can handle the pressures!
- Superior performance over a wide temperature range – 0° to 180° F (-18° to 82° C), even to 300° F (149° C) when Viton seals are used (consult factory).
- Micro-Air Cylinders have superior wear characteristics, thanks to the hard coated aluminum tubing I.D. In addition to an internal hardness of 60 Rockwell C, the barrel has an internal finish of 16 microinches or better.
- Micro-Air Cylinders are equipped with Series 303 stainless steel piston rods for corrosion resistance. Also, the ground and polished finish on the rods minimizes friction, providing longer packing life.
- Micro-Air Cylinders provide greater durability than disposable cylinders.



### Performance Specs

**Bore Sizes:** 3/4" and 1-1/8"  
**Maximum Output Force:** 199 pounds (1-1/8" bore)  
**Standard Operating Temperature range:** 0° to 180° F (-18° to 82° C)  
**Viton Seals Models:** For high heat applications. Consult factory.  
 Range of mounting styles and attachable mounts/ accessories to meet nearly any application requirement.

### Ordering

**01 XX - XXXX - 0 XX**

#### BORE SIZE

**76** 3/4 in.  
**18** 1-1/8 in.

#### CYLINDER TYPE AND MOUNTING STYLE

**1009** Double Acting, Double End Mount and Pivot Mount, BUNA-N Seals  
**5029** Double Acting, Nose Mount, Rear Port, BUNA-N Seals  
**1309** Double Acting, Double End Mount and Pivot Mount, Viton Seals  
**5329** Double Acting, Nose Mount, Rear Port, Viton Seals

#### STROKE LENGTH

WHOLE INCHES	FRACTIONS
0 = 0 in	0 = None
1 = 1 in	1 = 1/8 in
2 = 2 in	2 = 1/4 in
3 = 3 in	3 = 3/8 in
4 = 4 in	4 = 1/2 in
5 = 5 in	5 = 5/8 in
6 = 6 in	6 = 3/4 in
	7 = 7/8 in

(1/2" Increments, 1/2" through 6")

Maximum stroke length - 6-7/8-inches.  
 Consult factory for the other stroke requirements.

NOTE: Highlighted selections denote most popular models.

# Pneumatic Cylinders Micro-Air

## Dimensional Data

### Series 01

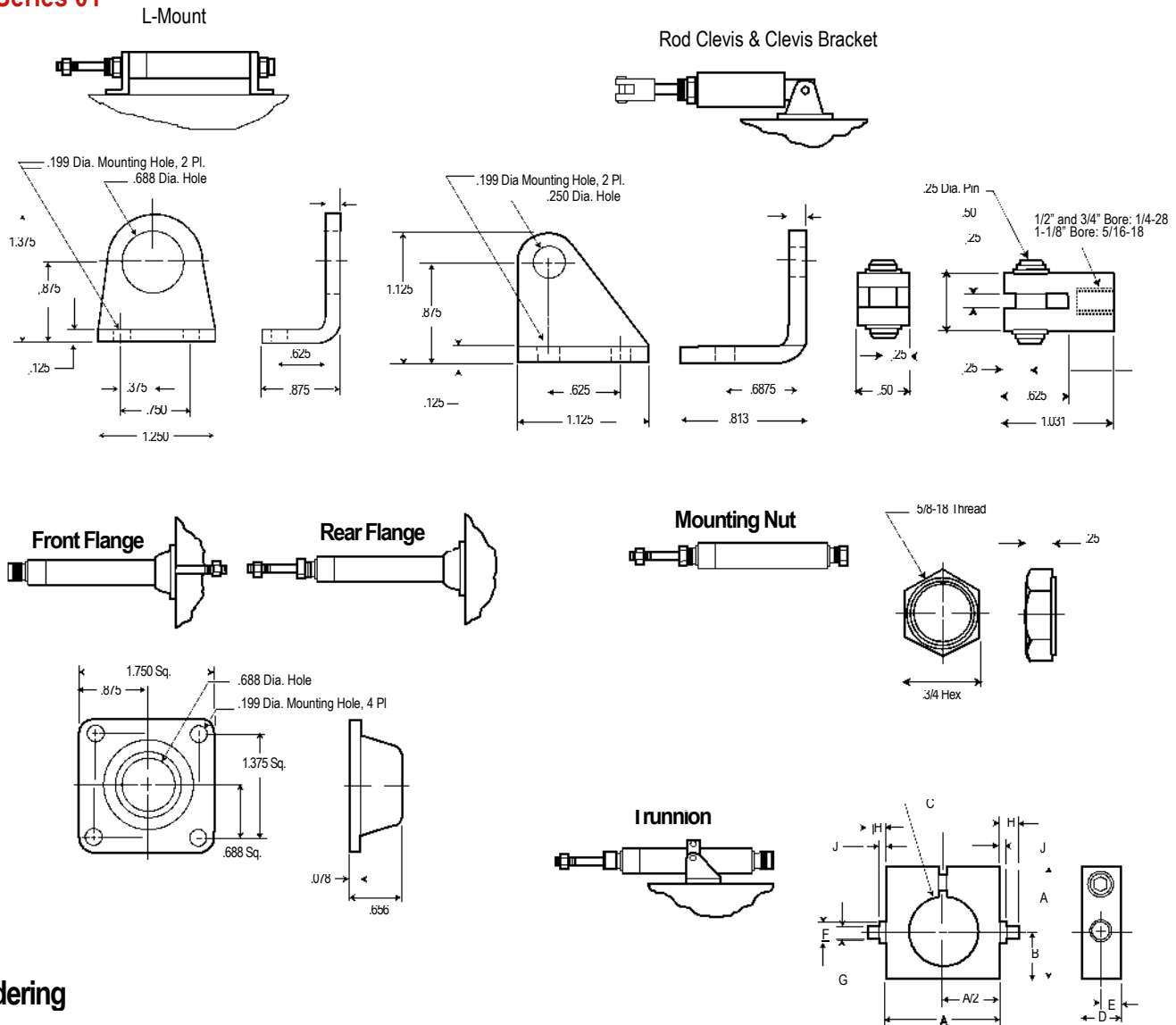

## Ordering

### Mounting Kit

	Cylinder Bore (Inches)	
	3/4	1-1/8
L-MOUNTS (2 Qty) *	20515	20515
FLANGE MOUNT *	20516	20516
MOUNTING NUT (2 Qty)	20514-1	20514-1
CLEVIS BRACKET	20519	20519
TRUNNION	20523	-
TRUNNION BRACKETS 20561		-
ROD CLEVIS	20517	20518-1

\* NOTE: Mounting nuts included.

### Trunnion Dimensions

Reference	Cylinder Bore (Inches)	
	3/4	1-1/8
A	1.50	2.25
B	.625	.875
C Dia.	.953	1.391
D	.500	.750
E	.250	.375
F Dia.	-	.563
G Dia. ± .002	.250	.437
H ± .010	.250	.438
J	-	.0625

\* 20561 Trunnion Bracket Kit (right and left brackets) is used for 20523 Trunnion. Reference Clevis bracket dimensions.

# Pneumatic Cylinders

## Dimensional Data

### Series 01

Reference	CYLINDER BORE (INCHES)	
	3/4	1-1/8
Rod Diameter	1/4	5/16
AA	2.438	2.688
BB	.625	.625
CC	.750	.750
CB	1.375	1.375
DD	.047	.047
EE	.281	.281
FF*	.719	.719
GG (± .002)	.682	.682
HH	1/4-28 UNF	5/16-18 UNC
JJ (UNF-2A)	5/8-18	5/8-18
KK	2	2
LL (NPTF)	11/8-27	1/8-27
MM	.912	1.350**
PP	.375	.375
QQ (SLOT) ± .002	.130	.130
RR (PIN)	.250	.250
SS	.625	.625
TT DIA.	.950	1.375

\* Note: FF shows total thread, including run out.

\*\* On rear head only of 5029 dimension is 1.291

