

ARO[®]

Pneumatic Valves and Motion Control

2, 3, and 4-Way Valves, available with electric, manual, mechanical, and pneumatic actuators. Miniature to full size valves.



Numeric Index

Number.....	Page	Number.....	Page	Number.....	Page	Number.....	Page	Number.....	Page
103-X.....	68	59121.....	104	59898.....	90	116572.....	83	CSL6-XXX.....	13
105-X.....	68	59125.....	103	59899.....	90	116573.....	83	CSN.....	79
109-X.....	68	59155.....	105	59900.....	90	116574.....	82, 83	CSN6.....	13
2XX-X.....	67	59156.....	104	59903.....	117	116575.....	82	CSN-30.....	79
225-X.....	67	59157.....	105	59905.....	117	116578.....	83	CSN MICRO.....	36
400-X.....	70	59158.....	104	59906.....	117	116579.....	83	EXXXXX-XXX-X.....	53
401-X.....	70	59159.....	105	59908.....	117	116647-XX.....	79	EV 30-A.....	72
402-X.....	70	59160.....	104	59912.....	103	116702.....	82	EV 35-A.....	72
447.....	70	59161-X.....	107	59913.....	87	116710.....	22	EV 125.....	72
448.....	70	59162-X.....	107	59914.....	87	116772.....	82	EV 250.....	72
449.....	70	59176-X.....	107	59915-XX.....	108	116773.....	82	EV 375.....	72
450.....	70	59165-4.....	105	59981.....	103	116807.....	22	FX- BK.....	78
46X-X.....	71	59166-4.....	104	59985.....	103	116808.....	22	HXXXX-XXX-X.....	62
600-X.....	75	59175-X.....	107	59916-X.....	115	116809.....	22	KXXXX-XXX-X.....	59
5030-XX.....	43	59191.....	86	59917.....	87	116862-1.....	23	MKN.....	22
5040-XX.....	43	59200-X.....	109	59919-1.....	91	116899-1.....	23	MKP.....	22
7000.....	82	59201-XX.....	109	59920.....	91	116904-1.....	23	M2XXXX.....	46, 49, 51, 69
7006.....	83	59361.....	113	59921.....	91	116916-1.....	23	M21XX-XXX-X.....	16
7007.....	83	59387.....	109	59922.....	91	116917-1.....	23	M21PS.....	69
7008.....	83	59463-X.....	117	59923.....	91	116926-1.....	23	M251PS.....	69
7010.....	83	59474-XXX.....	117	59924.....	91	117987.....	22	M26M02-XX.....	17
7012.....	83	59482.....	117	59925.....	91	118597-XXX.....	82	M30M03-XX.....	17
7102.....	83	59595-88.....	109	59972.....	113	18598-XXX.....	82	M34M04-XX.....	17
7103.....	83	59629.....	117	104094.....	77	11860X-X.....	23	M5XXXX.....	49
9600.....	72	5963X-100.....	117	104096.....	77	118612.....	23	M81XX-XXX-X.....	13
13111.....	43, 53, 71	59632-1.....	33	104104-XXX.....	77	118618.....	23	MP3651-7.....	53, 71
20308-X.....	74	59634.....	117	104484.....	69	11882X-X.....	82	MQ3620.....	82
20311-X.....	74	59636.....	117	104485.....	69	118823.....	82	MXXMB.....	17
20312-X.....	74	59671-X.....	106	104486.....	69	118824.....	82	NXX-BK.....	78
20313-X.....	74	59690-4.....	117	104487.....	69	119212-XX.....	82	P114400.....	36
20368.....	67	59718.....	106	114054.....	81	119213.....	82	P2X1-XXX-X.....	36
20370.....	73	59724-X.....	110	114155.....	13	119230.....	23	PTN.....	22
20467.....	73	59756-XXX.....	117	114417.....	49	119231.....	23	PEN.....	22
20965-X.....	53	59757-XXX.....	117	114418.....	46	119243.....	53, 71	PPN.....	22
20973-X.....	71	59759-XX.....	117	114419.....	46	119244.....	53, 71	PR-10.....	72
20975.....	71	59760-XX.....	117	114420.....	46	119245.....	53, 71	RKM21X-XX.....	82
24125.....	72	59761-XX.....	117	114421.....	46	119306.....	23	RKM81X-XX.....	82
24130.....	72, 110	59762-XX.....	117	114597-XX.....	51	119307-XXX.....	76	S5XXXX.....	7, 8
24135.....	72	59764-4.....	117	114598-XX.....	51	119308-XXX.....	76	SML51N-XX.....	7
58027.....	113	59765-XXX.....	117	114599.....	51	119309-XXX.....	76	SMH51X-XX.....	8
59010.....	103	59792.....	113	114803.....	13	119310-XXX.....	76	SMH81N-XX.....	13
59023.....	103	59800.....	103	114806.....	36	119350.....	11	SML81N-XX.....	13
59003-842.....	86	59801.....	114	114807.....	36	119351.....	11	SV10-C.....	74
59061.....	109	59802.....	114	114808.....	13	11936X.....	8	SV20-C.....	74
59062.....	109	59803.....	110	114822.....	46	119375.....	11	TBXX-XXX-X.....	38-41
59063.....	109	59804.....	110	1141XX-XX.....	13	119376.....	11	TNB14.....	4
59064-X.....	111, 112	59807.....	117	114772-XX.....	79	119690-XX.....	79	TNM1X-XX.....	4
59065-X.....	111, 112	59808.....	86	114645.....	49	119698-X.....	34	TNXXXX-XXX-X.....	4
59066-XX.....	112	59809.....	86	114829.....	26	119892-XX.....	7, 8	TPXXXX-XXX-X.....	26
59067-XX.....	111	59812-X.....	110	114834.....	26	119893-XX.....	7, 8	TSXXX-XXX-XX.....	40
59068-XX.....	111, 112	59860.....	87	114836.....	26	AXXXX-XXX-X.....	21		
59089.....	108	59861.....	87	114839.....	26	CATXX-XXX-X.....	32-35		
59095-X.....	114	59866.....	108	114840.....	26	CBW.....	79		
59097-6.....	113	59874.....	105	114841.....	26	CDN.....	79		
59100-XXX.....	115	59875.....	105	114842.....	26	CDL-XXX.....	79		
59109.....	108	59879.....	104	114843.....	26	CDW.....	79		
59111.....	103	59881.....	105	115046-XX.....	79	CDW-30.....	79		
59114.....	105	59882.....	105	115064-XX.....	79	CHL-XXX.....	79		
59115.....	106	59890.....	108	115422-1.....	23	CHL6-XXX.....	13		
59116.....	106	59891.....	108	115455-1.....	23	CHW.....	79		
59117.....	106	59892.....	104	116153.....	56	CHW6.....	13		
59124.....	103	59895.....	90	116218-XX.....	79	CHW-30.....	79		
59112.....	103	59896.....	90	116345-X.....	33	CPXX-B.....	78		
59120.....	105	59897.....	90	116464.....	23	CSL-XXX.....	79		

Table of Contents

Valves

Actuator Styles

Page

Manual

Max Air	46, 50, 69
50 Series	42
E Series	52
K Series	58
200 Series	66
460 Series	71

Mechanical

Maxair	50, 69
50 Series	42
E Series	52
100 Series	68
200 Series	66
400 Series	70

Pilot

Max Air	16
50 Series	42
E Series	52
K Series	58
H Series	62
200 Series	66
Alpha	20

Solenoid

Max Air	16, 38
Sierra	4, 26
Alpha	20
CAT	32
E Series	52
H Series	62
K Series	58
Premair	36

Accessories and Specialty Valves

24130 Button Bleeder	72
24135 Button Bleeder	72
9600 Pilot Bleeder	72
EV-30-A Quick Exhaust	72
PR10 Single Pulse Relay	72
SV10-C Shuttle	73
SV20-C Shuttle	73
20370 Micro Switches	73
20467 Micro Switches	73
20311-X Breather	74
20312-X Muffler	74
20313-X Speed Control	74
20308-X Exhaust Silencer	74
600 3-Way Sleeve	75
Coils and Connectors	79
Tubing, Fittings and Connectors	116
Flow Controls	76, 77, 78

Air Pneumatic Logic Controls

Specifications	85
Two -Hand Anit-Tie-Down	86
Flex-6 Accessory Units	87
Flex-6 Controls	88
Logic Elements	103
Indicators	110
Enclosures	113
Counters	114
Liquid Level Sensors	116
Fittings	117
Panell Mounted Valves	111, 112

Repair Kits

Repair Kits	82, 83
-------------------	--------

Descriptions

Sierra Series

Compact 2-position, 4-way valves that are lightweight, yet durable. 10mm, 15mm or 18mm wide. Body ported or sub-base mounted. Single and double solenoids available. M5 (10-32) and 1/8" ports.

The logo for the Sierra Series, featuring the word "SIERRA" in a bold, black, sans-serif font. To the right of the text is a small, stylized graphic of a mountain range with a sun or moon rising behind it.

(Page 4, 26)

MaxAir Series

2, 3 and 4-way air solenoid, pilot and hand lever valves feature excellent flow in a compact, lightweight package.

The logo for the MaxAir Series, featuring the word "MAX" in a large, bold, black, sans-serif font. To the right of "MAX" is the word "Air" in a smaller, lighter, sans-serif font. A vertical line runs through the "A" in "MAX".

(Page 16, 38, 46, 50, 69)

Alpha Series

High flow, 2-and-3-position, 4-way valves that are compact in size with many features. The family includes: Body Threaded, Stacking, Bar Manifold and Assembled Manifold. Single and double solenoids, or pilot actuators are available. 1/8", 1/4" and 3/8" ports.

The logo for the Alpha Series, featuring the word "ALPHA" in a large, bold, black, sans-serif font. A small "TM" trademark symbol is located to the upper right of the "A".

(Page 20)

Cat Series

Small, 3-way solenoid valves. Perfect for small bore, single acting cylinders and electric to air interfacing applications. Body ported for stand alone applications, stacking or base manifold. Available as normally open or normally closed. 1/8" and 1/4" ports.

The logo for the Cat Series, featuring the word "Cat" in a large, bold, black, sans-serif font. The "C" is significantly larger than the "at". Below the "at" is the text "Series Valves" in a smaller, black, sans-serif font.

(Page 32)

50 Series

3-way and 4-way body ported valves. Six manual, mechanical and pilot actuator styles available. 1/8" ports.

The logo for the 50 Series, featuring the number "50" in a large, bold, black, sans-serif font. To the right of "50" is the text "Series Valves" in a smaller, black, sans-serif font.

(Page 42)

E-Series

3-way and 4-way body ported valves. Nine manual, mechanical, pilot and solenoid actuator styles available. 1/4" ports.

The logo for the E-Series, featuring the letter "E" in a large, bold, black, sans-serif font. To the right of "E" is the text "Series Valves" in a smaller, black, sans-serif font.

(Page 52)

K-Series

Manual, Pilot and Solenoid, heavy duty 4-way valves. Available as body ported. Seven actuator styles available. Manual: 3/8" and 1/2" ports. Solenoid and Pilots: 3/8", 1/2", 3/4" and 1" ports.

The logo for the K-Series, featuring the letter "K" in a large, bold, black, sans-serif font. To the right of "K" is the text "Series Valves" in a smaller, black, sans-serif font.

(Page 58)

H-Series

High flow 3-and-4-way function Poppet valves. Available in solenoid, pilot and bleed actuators. 1/4", 3/8" and 1/2" ports.

The logo for the H-Series, featuring the letter "H" in a large, bold, black, sans-serif font. To the right of "H" is the text "Series Valves" in a smaller, black, sans-serif font.

(Page 62)

Premair™

3-and-4-way direct acting solenoid valve. Rugged construction and lightweight, stand alone and stacking. Available in 1/8" ports.

The logo for the Premair series, featuring the word "Premair" in a bold, black, sans-serif font. The "P" is significantly larger than the other letters.

(Page 36)

Accessories

Accessory Valves

- 100 Series - 3-way N.C., miniature limit valves.
- 200 Series - 3-way limit valve-ideal for sensing devices such as cylinders, slides and gates.
- 400 Series - Heavy duty 3-way limit valves, 4 actuator arms available.
- 460 Series - 3-way palm button valves.
- The 200, 400 and 460 are multipurpose valves, plumb N.O., N.C., diverter, and selector.
- In line and right angle flow controls, in line needle and check valves.



200 Series Valve



460 Series Valve

Valve Accessories and Special Valves

- Bleed valves: manual button and pilot operated.
- Quick exhaust valves for enhancing cylinder speed.
- One shot pulse valve to convert continuous air supply to a momentary output.
- Shuttle valves operate as a check when two inlets are required.
- Micro switch converts pneumatic signal into an electric signal.
- Exhaust mufflers, exhaust speed controls, breather vents.



Quick Exhaust Valve



Exhaust Muffler

Pneumatic Logic Controls

- Two-hand anti-tie-down unit for monitoring operators hands during work cycle.
- Pneumatic pulse and delay timers for use in simple valve circuitry.
- Pneumatic counters.

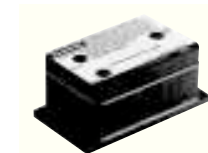

2-Hand Anti-Tie Down

Features

Sierra TN Series Miniature Manifold Valves are excellent choices for:

- | | |
|-------------------------|-----------------|
| Dispensing Applications | Control Systems |
| Converting Applications | Food Processing |
| Packaging Applications | Animation |

3-Way Valves

- Single Solenoid
- Normally Closed, Direct Acting
- Low Power Consumption
- Compact Space Saving Design
- Large Flow Capacity Cv 0.01

4-Way Valves

- Quick Response and Large Flow capacity
- High Reliability
- Compact size
- Single Solenoid, Double Solenoid,
- 2-Position, 3-Position Spring Centered
- Low Power Consumption

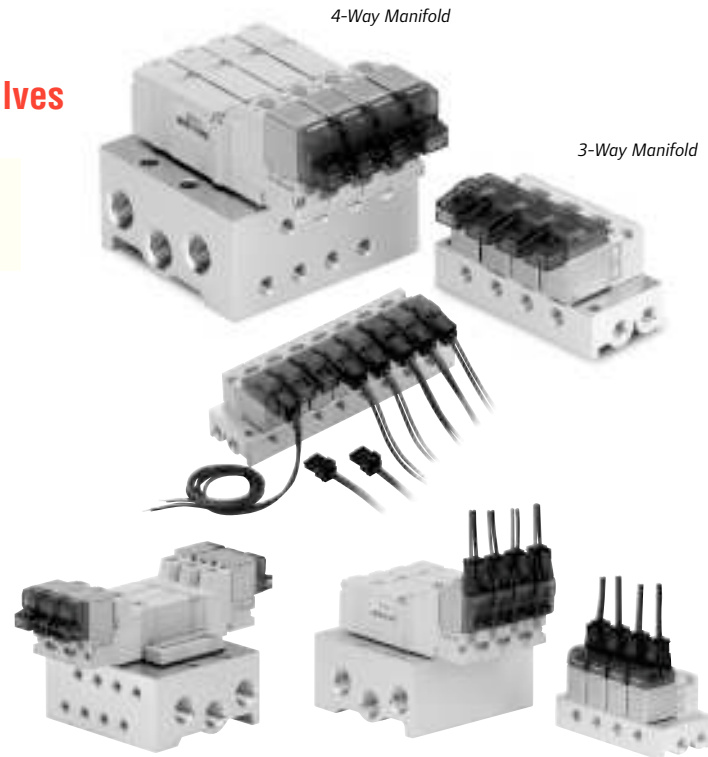

4-Way Manifold, Double Solenoid

Vertical Electrical Entry available: Consult Factory

Ordering

Number	Description	Model Voltage	Watts/VA
Valves			
3-Way			
TN15M5S-012-H	3-Way Solenoid/Spring Return	12 VDC	1.0
TN15M5S-024-H	3-Way Solenoid/Spring Return	24 VDC	0.6
TN15M5S-120-H	3-Way Solenoid/Spring Return	110 VAC	1.4
4-Way			
TN1210S-012-H	4-Way Solenoid/Spring Return	12 VDC	1.0
TN1210S-024-H	4-Way Solenoid/Spring Return	24 VDC	0.6
TN1210S-120-H	4-Way Solenoid/Spring Return	110 VAC	1.6
TN1210D-012-H	4-Way 2 Position Solenoid/Solenoid	12 VDC	1.0
TN1210D-024-H	4-Way 2 Position Solenoid/Solenoid	24 VDC	0.6
TN1210D-120-H	4-Way 2 Position Solenoid/Solenoid	110 VAC	1.6
All Ports Blocked			
TN1310D-012-H	4-Way 3 Position Spring Centered	12 VDC	1.0
TN1310D-024-H	4-Way 3 Position Spring Centered	24 VDC	0.6
TN1310D-120-H	4-Way 3 Position Spring Centered	110 VAC	1.6

Vertical Electrical Entry available: Consult Factory

Model Number	M5 Ports	Model Number	10-32 NPT Ports
--------------	----------	--------------	-----------------

Manifold*

3-Way		4-Way	
TNM15-01	Single Station	TNM14-02	2 Stations
TNM15-02	2 Stations	TNM14-04	4 Stations
TNM15-03	3 Stations	TNM14-06	6 Stations
TNM15-04	4 Stations	TNM14-08	8 Stations
TNM15-05	5 Stations	TNM14-10	10 Stations
TNM15-06	6 Stations		
TNM15-07	7 Stations		
TNM15-08	8 Stations		
TNM15-09	9 Stations		
TNM15-10	10 Stations		

Blanking Kit

TNB14

* Other manifolds available up to 16 stations. Consult factory.



3-Way 2 station manifold



4-Way 4 station manifold

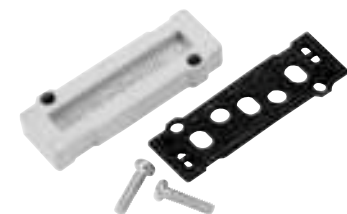

Blanking Kit TNB14 (4-way only)

Performance Specifications

	3-Way	4-Way
Body Style	Manifold Mount	Manifold Mount
Media	Air	Air
Temperature Range	44-122 F (5-50 C)	44-122 F (5-50 C)
Operating Pressure		
2-Position Single	0-100 PSIG (0-7 Bar)	20-100 PSIG (1.5-7 bar)
2-Position Double	N/A	15-100 PSIG (1-7 bar)
3-Position	N/A	30-100 PSIG (2-7 bar)
Cv Factor	0.01	0.2
Response Time	10ms	12ms
Power Consumption	DC 1.0 W 12 VDC, .6W 24 VDC AC 1.4 W	DC 1.0 W 12VDC, .6W 24 VDC AC 1.6 W
Lead Entry	Horizontal	Horizontal
Manual Override	Non-Lock Push	Push & Lock
Lubrication	None Required	None Required
Connection	IP65 Rating	IP65 Rating

Dimensional Data

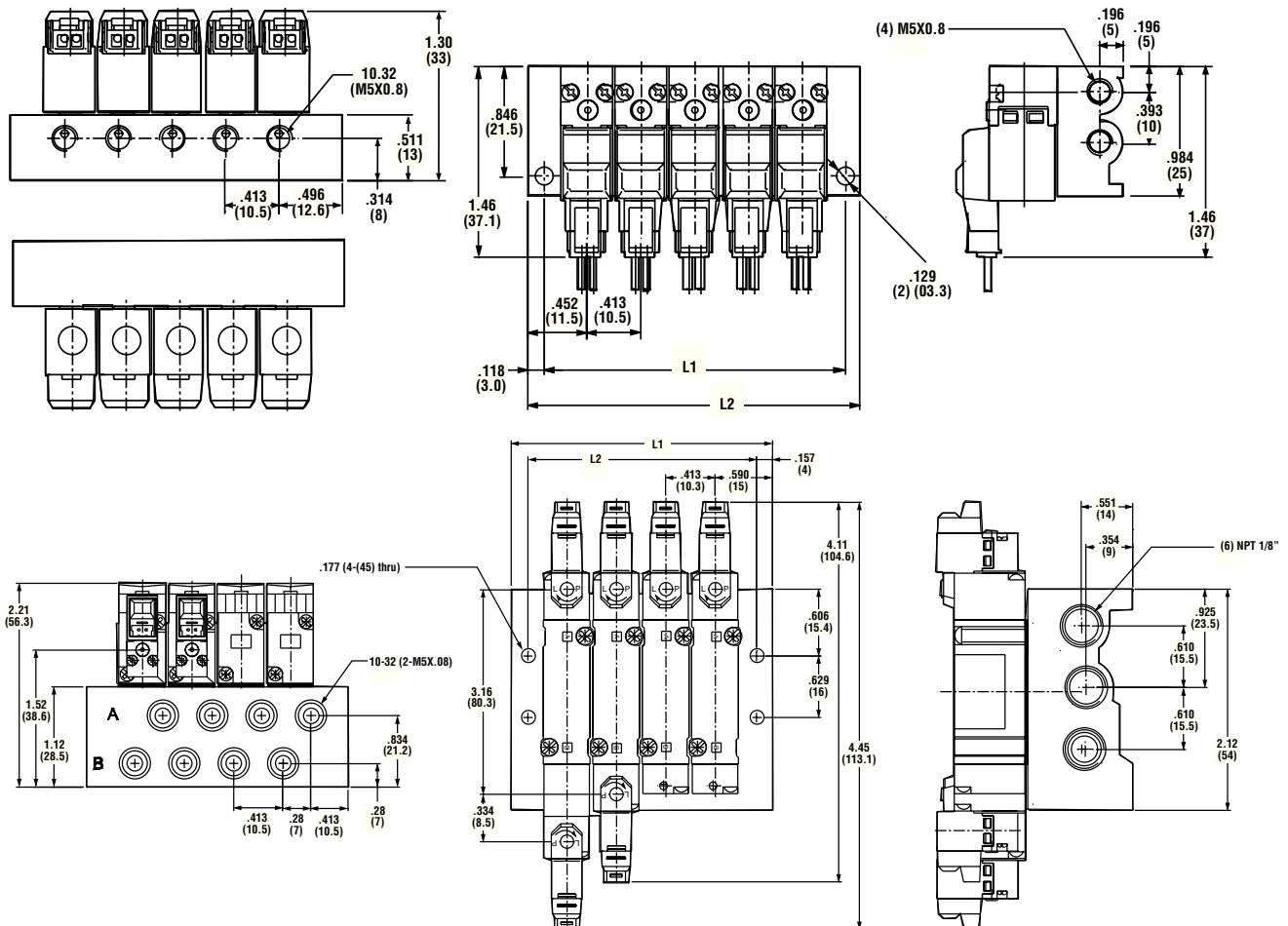

3-Way Manifold

Stations	2	3	4	5	6	7	8	9	10
L1	1.31 (33.5)	1.73 (44)	2.14 (54.5)	2.56 (65)	2.97 (75.5)	3.38 (86)	3.80 (96.5)	4.21 (107)	4.62 (117.5)
L2	1.08 (27.5)	1.50 (38)	1.91 (48.5)	2.32 (59)	2.74 (69.5)	3.15 (80)	3.56 (90.5)	3.98 (101)	4.39 (111.5)

4-Way Manifold

Stations	2	4	6	8	10
L1	1.51 (38.5)	2.34 (59.5)	3.17 (80.5)	4.00 (101.5)	4.82 (122.5)
L2	1.20 (30.5)	2.03 (51.5)	2.85 (72.5)	3.68 (93.5)	4.50 (114.5)

Features

At Last. A Miniature Valve with Maximum Range.

Body-Ported:

- 2-position single and double solenoid models.
- Two wiring options: Lead Wire and Plug-In.
- Available in 120V AC, 24V DC or 12V DC.
- Body-Ported valves can be mounted on low profile manifold to simplify installation when using multiple valves.

Base Mounted:

- 2-position single and double solenoid models.
- Standard 2-, 4-, 6-, 8-, 10-, 12- and 16 stations.
- Stand-alone subbase (for 1-station) with M5 (10-32) or 1/8" NPT(F) ports.
- Two wiring options: Lead Wire and Plug-In and three voltage options 120V AC, 24V DC or 12V DC.

One-Touch Manual Valve Override (Standard)

Mechanical valve override is nonlocking spring return push with tool.

Wiring and Voltage Options

Lead-Wire Style: Valve lead wires come stripped and preattached to the coil (NEMA 4). All models are available in either 120V AC, 24V DC. 12V DC Available on plug in only.

Manifold Options

Manifolds are available in 2, 4, 6, 8, 10, 12 and 16-station configurations. Sierra manifolds are available with 1/8" NPT(F) ports. Sierra Valves and Manifolds are sold separately.

Stand-alone sub-bases available in M5 (10-32) or 1/8" NPT, for use with manifold mount valves only.

Superior flow capacity, an unrivaled array of “real-world” design features and options, a valve body that is both ultra-compact and lightweight—yet exceptionally durable—this is Sierra 15, the miniature valve with the maximum range.

Ultra-Compact Valve Design

At only 15 mm wide, Sierra 15 is the one compact valve that’s going to fit your valve location requirements – with room to spare.

Durable Body Construction

Sierra’s body features bar stock aluminum construction, producing a light weight, yet durable valve.



Sierra Valves on SML51N-02 Low Profile Manifold

Performance Specifications

Pressure Range:	22 to 115 PSI (0.8 M pa)
Shift Pressures:	22 PSI Single or Double-Solenoid
Flow:	9 SCFM, .25 Cv
Operating Medium:	Compressed Air
Lubrication:	None Required
Cycle Rate:	120 Cycles Per Minute
Temperature Rating:	0° to 122°F (-17° to 50°C)
Signal Response Time	14 ms
Rated Voltage:	120V AC, 24V DC and 12V DC
Current Ratings:	120V AC = 16 mA in-rush; 11 mA holding 12V DC & 24V DC = 67 mA
Power Consumption:	2.1/1.8 VA 1.9 W

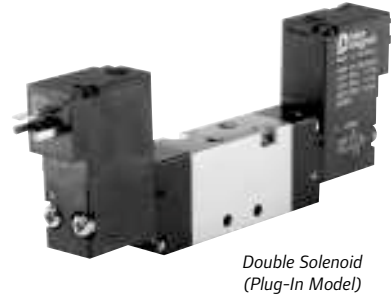
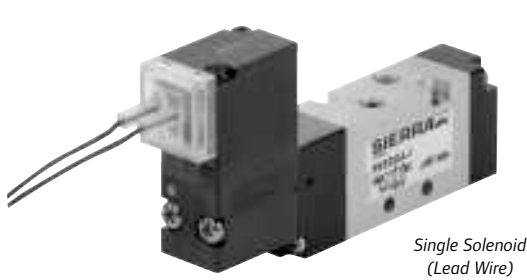

Ordering

Sierra Valve Size		S5	X	S	M	X - 1
Code	Description					Coil Style/ Voltage
S5	15 mm					A Lead Wire, 120V AC
Number of Coils						B Lead Wire, 24V DC
Code	Description					C Plug-In, 120V AC
S	Single Solenoid, Spring Return					D Plug-In, 24V DC
D	Double Solenoid					F Plug-In, 12V DC
Valve Style						A, B NEMA 4 Rating
Code	Description					C, D & F NEMA 2 Rating
S	Standard Solenoid Operator					Body Style
						Code Description
						M M5 (10-32)

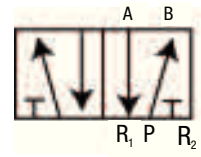

Low Profile Manifold

SML51N		-	XX
Sierra Manifold:			Number of Stations
15mm valve low profile manifold with 1/8" Supply and Exhaust Ports			Code Description
			02 2 Stations
			04 4 Stations
			06 6 Stations
			08 8 Stations

NOTE: Low Profile Manifolds are for use with Body Ported Valves only. One gasket and two screws are provided per station.

Replacement Coils

Part Number	Description	Part Number	Description
119892-33	120 VAC Plug-In	119893-33	120 VAC Lead Wire
119892-39	24 VDC Plug-In	119893-39	24 VDC Lead Wire
119892-38	12 VDC Plug-In		

8 | Sierra 15 • Pneumatic Valves



Single Solenoid
(Plug-In Model)

Ordering

Base-Mounted Valves

S5 X X 9 X - 1

Sierra Valve Size

Code	Description
5	15 mm

Number of Coils

Code	Description
S	Single Solenoid, Spring Return
D	Double Solenoid

Valve Style

Code	Description
S	Standard Solenoid Operator

Body Style

Code	Description
9	Base Mounted

Coil Style/ Voltage

Code	Description
A	Lead Wire, 120V AC
B	Lead Wire, 24V DC
C	Plug-In, 120V AC
D	Plug-In, 24V DC
F	Plug-In, 12V DC
A, B	NEMA 4 Rating
C, D & F	NEMA 2 Rating

When raceway option is used, requires a 119354 Single Solenoid or 119355 Double

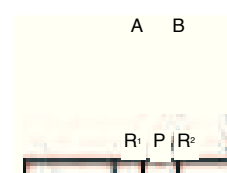

Subbase

11936 X

Port Size

Code	Description
7	M5 Subbase (10/32" threads)
8	1/8" Subbase



Sierra Valve on M5
Stand-alone Subbase

Manifold

SMH51 X - XX

Sierra Manifold:

15mm valve with 1/8" Ports

Wiring Configuration

Code	Description
N	Normal Manifold

Number of Stations

Code	Description	Code	Description
02	2 Stations	10	10 Stations
04	4 Stations	12	12 Stations
06	6 Stations	16	16 Stations
08	8 Stations		



Manifold Close-Up

Replacement Coils

Part Number	Description	Part Number	Description
119892-33	120 VAC Plug-In	119893-33	120 VAC Lead Wire
119892-39	24 VDC Plug-In	119893-39	24 VDC Lead Wire
119892-38	12 VDC Plug-In		

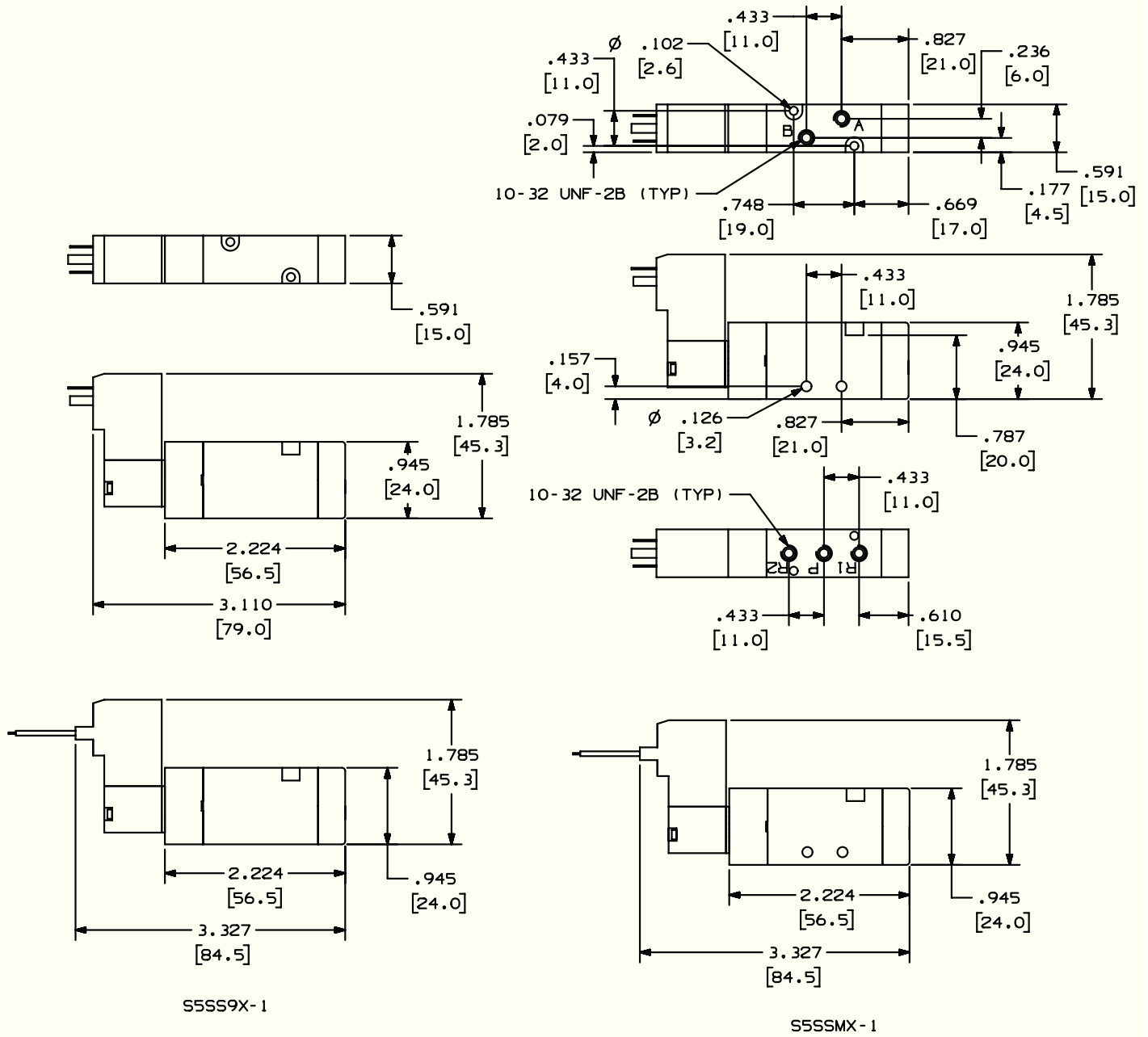

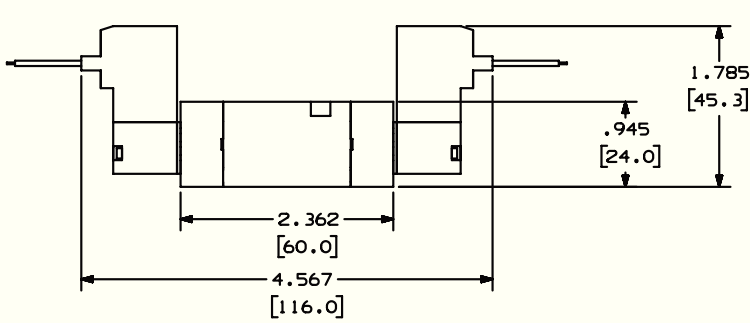
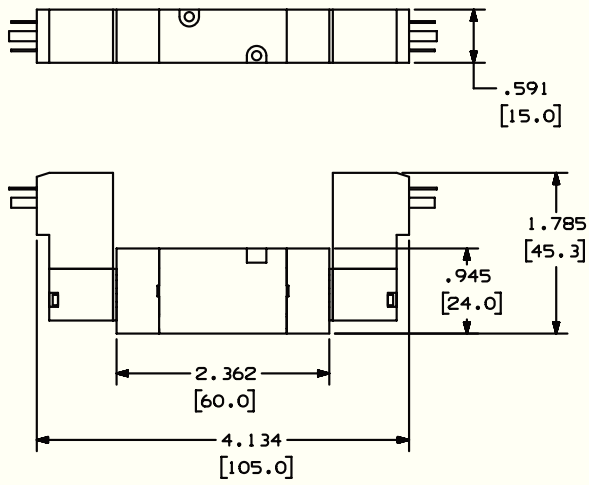
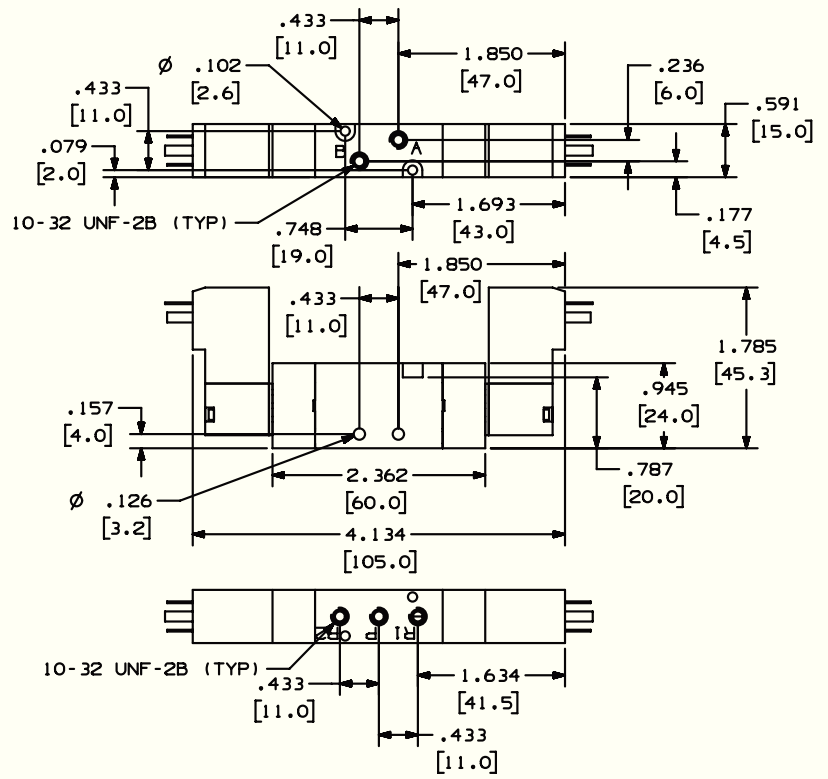

S5DS9X-1

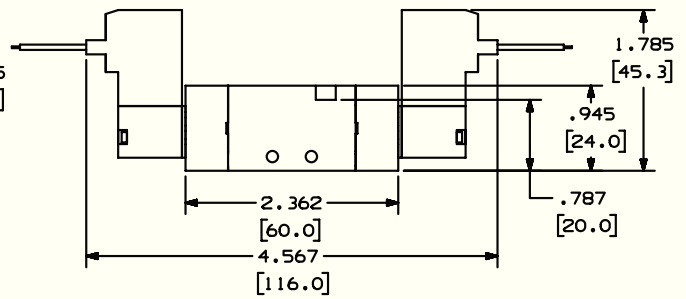

S5DSMX-1

NUMBER OF STATIONS	L1	L2
2	2.323 (59.0)	1.850 (47.0)
4	3.661 (93.0)	3.189 (81.0)
6	5.000 (127.0)	4.528 (115.0)
8	6.339 (161.0)	5.866 (149.0)
10	7.677 (195.0)	7.205 (183.0)
12	9.016 (229.0)	8.543 (217.0)
16	11.693 (297.0)	11.220 (285.0)

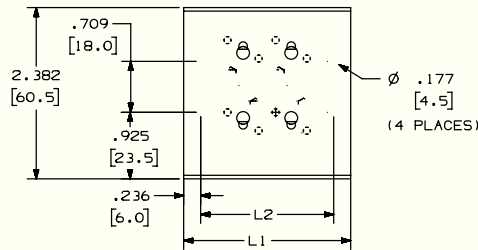

Standard Manifold Dimensions

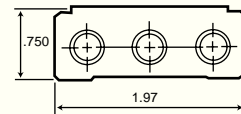

No. of Stations	"A"
2	2.323 (59)
4	3.661 (91)
6	5.000 (127)
8	6.339 (161)
10	7.678 (195)
12	9.017 (229)
14	10.356 (263)
16	11.695 (297)

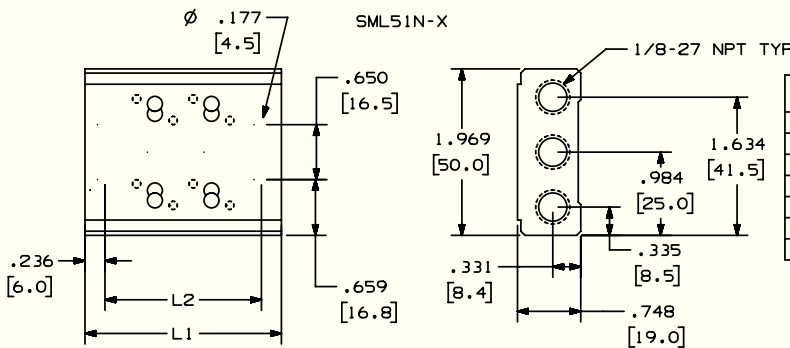
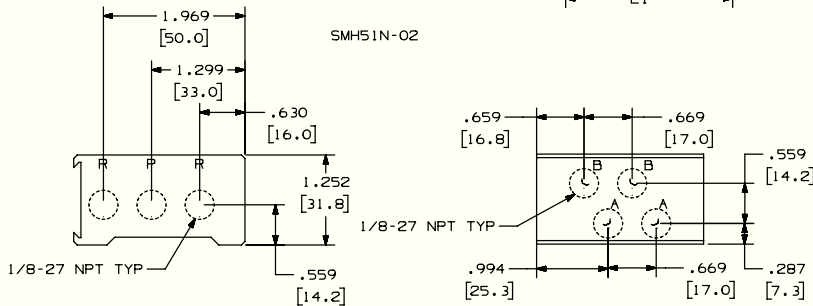

NUMBER OF STATIONS	L1	L2
2	2.323 (59.0)	1.850 (47.0)
4	3.661 (93.0)	3.189 (81.0)
6	5.000 (127.0)	4.528 (115.0)
8	6.339 (161.0)	5.866 (149.0)
10	7.677 (195.0)	7.205 (183.0)
12	9.016 (229.0)	8.543 (217.0)
16	11.693 (297.0)	11.220 (285.0)

Additional Valve Accessories

119351 Blanking Plate

Gasketed metallic plate installs in minutes and caps off unused manifold ports. Order one plate per valve station.

119375 Replacement Gasket/Fastener

Kit contains Valve Gasket, Block Gasket, Valve-to-Manifold Screw, Replacement Shut-Off Block to Manifold Screw, Replacement Raceway Screw and Replacement Manifold Blanking Plate.

119376 Pipe Plug Kit

Contains 3 (ea.) 1/8" pipe plugs.

Ordering

119350 "Sandwich" Shut Off Block

Allows a specific manifold valve to be removed without shutting down pressure to rest of the manifold.

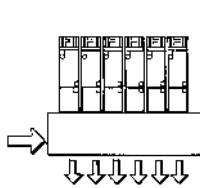

One Solenoid Valve needs to be replaced during set-up.

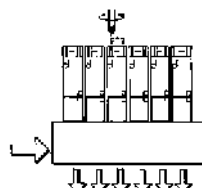

Loosen the valve's retaining screws and lift off valve.

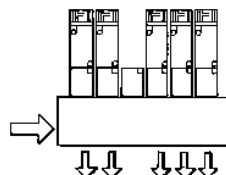

Removing the valve automatically causes the Shut-Off Block to close the valve ports leading to the manifold.

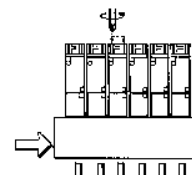

Replacing the valve automatically reopens the ports and reenergizes the new valve.

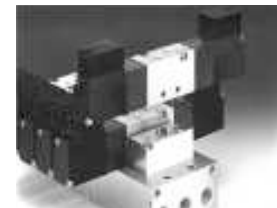

119350 "Sandwich" Shut-off Block for Manifold Valves

IMPORTANT: The Shut-off Block option is intended for machine setup convenience only. When performing routine maintenance on machinery, always observe proper lock-out/ tag-out procedures.

Features

Sierra® 18 (1/8” Ports) 4-Way, Compact Air Valves

18mm Wide Body and 1/8” Ports Fill The Bill Between Mini and Medium Flow Valves

Larger than its 15mm Sierra® counterpart yet smaller than the Alpha® valve, the Sierra 18 is the perfect fit for valve applications that require a compact, 4-way valve with plenty of options and features. The new Sierra 18 valves are equally ideal where fast signal response (18ms avg.) with moderate flow (.5 Cv, 3-position, .7 Cv 2-position) is required.

3-Position Spool Function Provides Wider Application Flexibility:

Sierra 18 offers three distinct, 3-position spool configurations for a wide variety of applications:

- All ports blocked in center
- Cylinder ports open to exhaust in center, supply blocked
- Cylinder ports pressurized in center, exhaust ports blocked

2 Styles Available: Choose Between Body-Threaded or Manifold - Mounted:

The Sierra 18 is a body - threaded valve that can be directly plumbed or mounted to a low profile manifold. The Sierra 18 is also available as a true manifold valve. Where there’s a need for multiple valves in tight spots, especially in machine design operations, the Sierra 18 is the compact valve with complete flexibility and delivery.

Solenoid Coils and Connectors Provide Quick, Clean Connections:

Coils are Class F rated for 100% duty cycle applications at 122° F (50° C) . AC or DC coils can be interchanged on the same solenoid stem. Each Solenoid connector acts as its own junction box, with molded connectors and gaskets to protect electrical connections. Design meets NEMA-4 classifications.



One - Touch Manual Override (Standard):

Sierra 18 contains a mechanical valve non-locking override.

Manifolds Available in 2, 4, 6, 8, 10, and 16-Station Configurations.



Performance Specifications

Pressure Range:	115 PSI (7.8 bar)
Shift Pressure:	22 PSI
Flow:	30 SCFM .7 Cv (2-Position Valves) 21 SCFM .5 Cv (3-Position Valves)
Operating Medium:	Compressed Air
Cycle Rate:	120 Cycles Per Minute
Temp. Rating:	0° to 122° F (-17° to 50° C)
Lubrication:	None Required
Signal Response Time:	17ms (AC), 22s (DC)

Rated Voltage	Power Consumption		Current Draw	
	In-rush	Holding	In-rush	Holding
120 VAC	3.1 VA	2.2 VA	26 mA	18 mA
12 VDC	1.9 W	1.9 W	154 mA	154 mA
24 VDC	2.0 W	2.0 W	85 mA	85 mA

Ordering

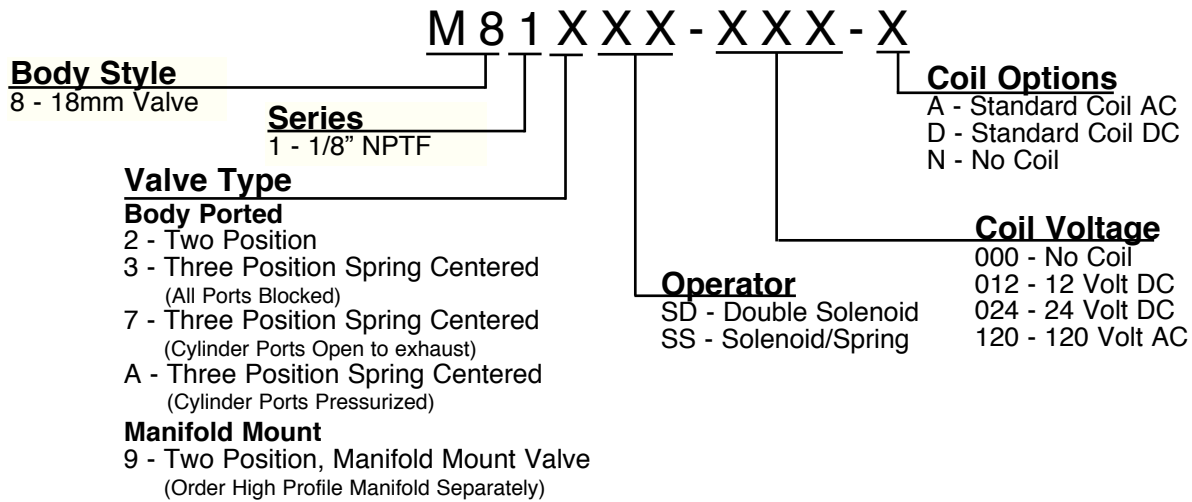

Low Profile Manifold & Blanking Plate

Model	Description
SML81N-02	2-Station Manifold
SML81N-04	4-Station Manifold
SML81N-06	6-Station Manifold
SML81N-08	8-Station Manifold
SML81N-10	10-Station Manifold
SML81N-16	16-Station Manifold
114155	Blanking Plate
114803	Replacement Gasket/Screw Kit
	<i>(One Gasket & Two Screws)</i>



Connector & Coil

Model	Description
CHL6-012	12 VDC molded cable connector w/indicator light, 39" leads
CHL6-024	24 VDC molded cable connector w/ indicator light, 39" leads
CHL6-120	120 VAC molded cable connector w/ indicator light, 39" leads
CHW6	16 mm molded cable connector, 39" leads
CSL6-012	12 VDC strain relief connector w/ indicator light
CSL6-024	24 VDC strain relief connector, w/ indicator light
CSL6-120	120 VAC strain relief connector, w/ indicator light
CSN6	16 mm, strain relief connector
114153-33	120 VAC, lead wire coil
114153-38	12 VDC, lead wire coil
114153-39	24 VDC, lead wire coil
114138-33	120 VAC, standard coil
114138-38	12 VDC, standard coil
114138-39	24 VDC, standard coil



High Profile Manifold & Blanking Plate

Model	Description
SMH81N-02	2-Station Manifold
SMH81N-04	4-Station Manifold
SMH81N-06	6-Station Manifold
SMH81N-08	8-Station Manifold
SMH81N-10	10-Station Manifold
114808	Blanking Plate



Dimensional Data

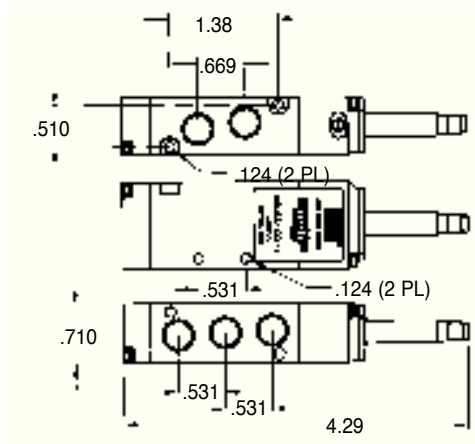

M812SS-XXX-X

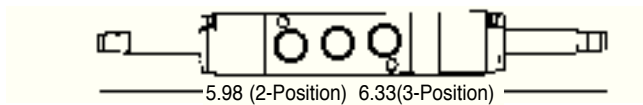

M812SD-XXX-X
M813SD-XXX-X

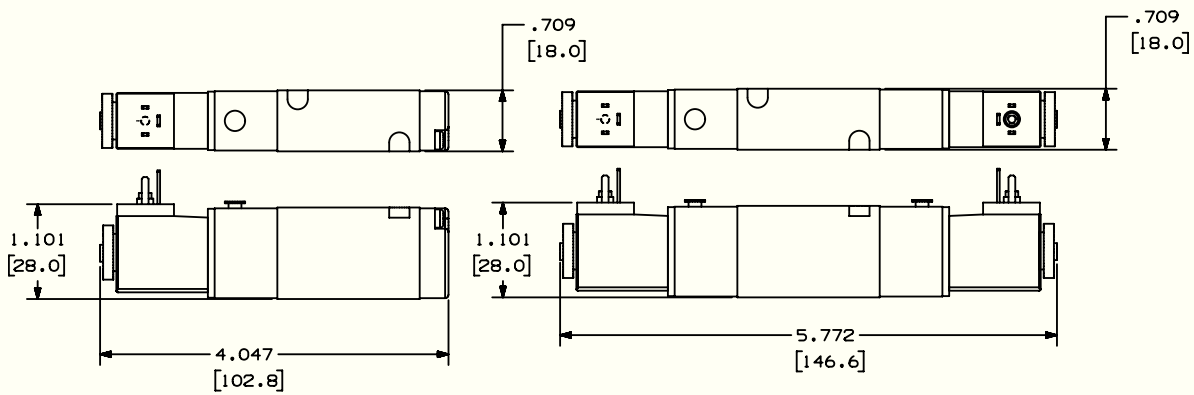

M819SS-XXX-X

M819SD-XXX-X

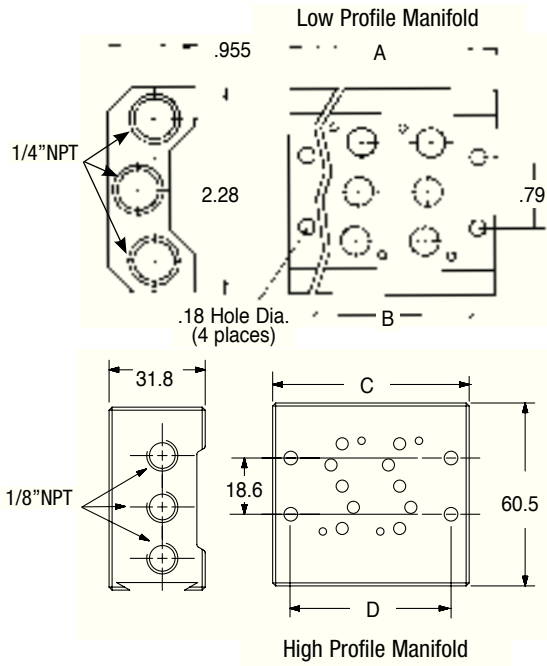

	A	B
2-Station	2.24	1.85
4-Station	3.74	3.35
6-Station	5.24	4.84
8-Station	6.73	6.34
10-Station	8.23	7.84

	C	D
2-Station	2.56	2.09
4-Station	4.06	3.59
6-Station	5.56	5.08
8-Station	7.05	6.58
10-Station	8.55	8.08

Fluid Technologies

[Home](#) [Products](#) [Industries](#) [Applications](#) [Support](#) [News](#) [Literature](#)



Dispensing Pumps



Lubrication Equipment



Piston Pumps & Packages



Dispense Solutions



Pneumatic Valves & Cylinders

ARO

Ingersoll Rand / ARO
FLUID TECHNOLOGIES

Progress in Motion

For more than 100 years, we've helped drive innovation with revolutionary technology — creating new standards for how the world gets work done. We've done it by producing best-in-class Ingersoll Rand / ARO pump and dispensing technologies, and by knowing our customers' industries and the demands placed on productivity and quality.

No matter what your product, process or location, Ingersoll Rand / ARO offers a broad range of pumps and accessories, dispensing systems, and a world-wide distribution and service network prepared to solve your fluid handling challenge.



Visit Productivity Park

From Aerospace to Mining - Visit our virtual industrial park and see how our products improve your process.

Visit our website at ingersollrandproducts.com

Features

3-Way and 4-Way Air Solenoid & Pilot Valves 1/4", 3/8" & 1/2" NPT Ports

- Ideal for packaging, material handling and air motor applications
- Ideal for double acting pneumatic cylinders
- Compact size with excellent flow capacity
- Single and double solenoid or pilot models
- Three voltages available 120 VAC, 12 and 24 VDC
- Lightweight aluminum bodies and Buna-N seals are standard
- Manifold mounting available, blanking plates provided for future expansion
- Max/Air valves use Alpha style 22mm coil
- 1/4" = 26 mm Body Size
- 3/8" = 30 mm Body Size
- 1/2" = 34 mm Body Size

3-Position Spool Function Provides Wider Application Flexibility:

MaxAir offers 3-position spool configuration with all ports blocked in center.



Solenoid Coils and Connectors Provide Quick, Clean Connections:

Coils are Class F rated for 100% duty cycle applications at 122° F (50° C). AC or DC coils can be interchanged on the same solenoid stem. Each Solenoid connector acts as its own junction box, with molded connectors and gaskets to protect electrical connections. Design meets NEMA-4 specifications.



One - Touch Manual Override (Standard):

MaxAir contains a mechanical valve override that can be adjusted to a locking (push 'n twist) position or non-locking function.

Valves are Body-Threaded and can be Manifold - Mounted:

MaxAir is a body - threaded valve that can be directly plumbed or manifold - mounted. Where there's a need for multiple valves in tight spots, especially in machine design operations. Manifolds Available in 2, 4, 6, 8, 10, and 12 Station Configurations.

Ordering

M - 2 1 2 - SS* - 120 - A

<p>Valve Type*</p> <p>2=2 Position</p> <p>3=3 Position</p> <p>All Ports Blocked</p> <p>Spring Centered (Sol. & Pilot Only)</p> <p>* Model number ends here on pilot activated valves.</p>	<p>Body Style</p> <p>1=4 Way Side Ported</p> <p>5=3 Way Side Ported</p>	<p>Port Size</p> <p>2=1/4" NPT</p> <p>3=3/8" NPT</p> <p>4=1/2" NPT</p>	<p>Actuator/Return</p> <p>SS=Single Solenoid/Spring</p> <p>SD=Double Solenoid</p> <p>PS=Pilot / Spring*</p> <p>PD=Pilot / Double*</p>	<p>Coil Voltage</p> <p>000=No Coil</p> <p>012=12 VDC</p> <p>024=24VDC</p> <p>120=120VAC</p>	<p>Coil Options</p> <p>N=No Coil</p> <p>A=AC</p> <p>D=DC</p>
--	--	---	--	--	---

Performance Specifications

C_v (Solenoid) (Pilot)	1/4 = .70, 3/8 = 1.65, 1/2 = 4.32	Temp. Range	15° to 122° F (-10° to 50° C)
SCFM	1/4"= 26, 3/8"=61, 1/2"=150	Minimum Shift Pres.	2 position single pilot, single solenoid, spring return - 45 PSI
Port Size NPT	1/4", 3/8", 1/2"		2 position double pilot - 45 PSI
Operating Medium	Non-Lubricated or Lubricated Air		2 position double solenoid-20 PSI
Pres. Range (Solenoid)	45 - 115 PSI		3 position double solenoid, double pilot, spring centered - 45 PSI
Pres. Range (Pilot)	45 - 140 PSI		
Duty Cycle	100%		

Ordering

Manifold

No. of Stations	1/4" NPT Ports	3/8" NPT Ports	1/2" NPT Ports
2	M26M02-02	M30M03-02	M34M04-02
4	M26M02-04	M30M03-04	M34M04-04
6	M26M02-06	M30M03-06	M34M04-06
8	M26M02-08	M30M03-08	M34M04-08
10	M26M02-10	M30M03-10	M34M04-10



Manifold Kits

Kits include: manifold, seals and valve attaching hardware

22mm Connector

Model	Description	
CHW	Straight connector with cable (36") located on top	
CBW	Straight connector with cable (36") located on back	
CHL-XXX	Straight connector (36") with indicator light located on back.	
CSN	Strain relief, without indicator light or cable.	
CSL-XXX	Strain relief, with indicator light located on the back.	
CDN	1/2" conduit without light or lead wire	
CDW	1/2" conduit without light, 18" lead wire	
CDL-XXX	1/2" conduit with light, 18" lead wire	

Dimensional Data

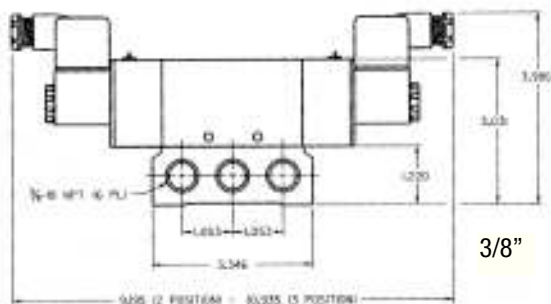
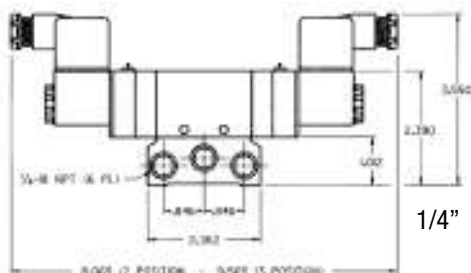
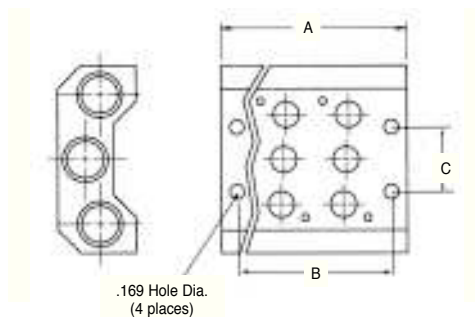

Voltage (-XXX)

012 = 12 VDC/VAC 024 = 24 VDC/VAC 120 = 120 VDC/VAC

Blanking Plate Kit

M26MB Fits 1/4" (26 mm) manifolds

M30MB Fits 3/8" (30 mm) manifolds

M34MB Fits 1/2" (34 mm) manifolds

Stations	1/4"			3/8"			1/2"		
	A	B	C	A	B	C	A	B	C
2	3.189	2.638	0.866	3.661	3.031	1.063	4.134	3.346	1.181
4	5.315	4.764	0.866	6.101	5.471	1.063	6.890	6.102	1.181
6	7.441	6.890	0.866	8.541	7.911	1.063	9.646	8.858	1.181
8	9.567	9.016	0.866	10.981	10.351	1.063	12.402	11.614	1.181
10	11.693	11.142	0.866	13.421	12.791	1.063	15.158	14.370	1.181

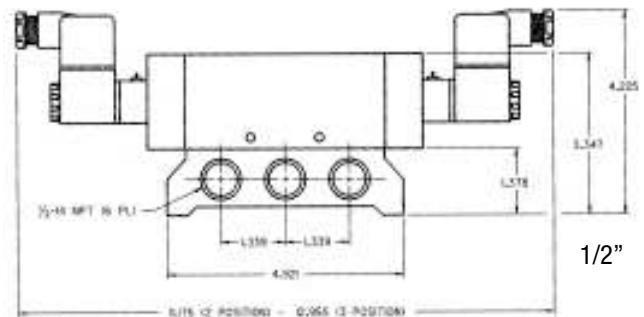

Dimensional Data

Solenoid

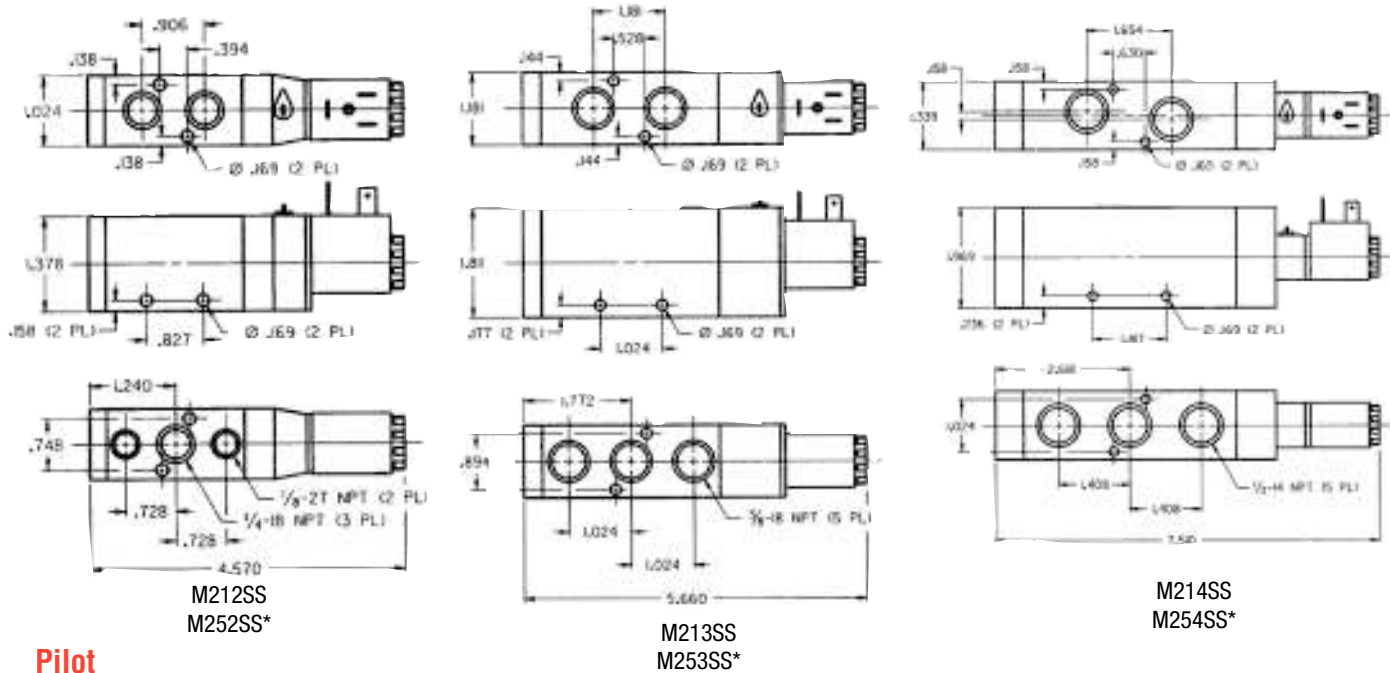

Pilot

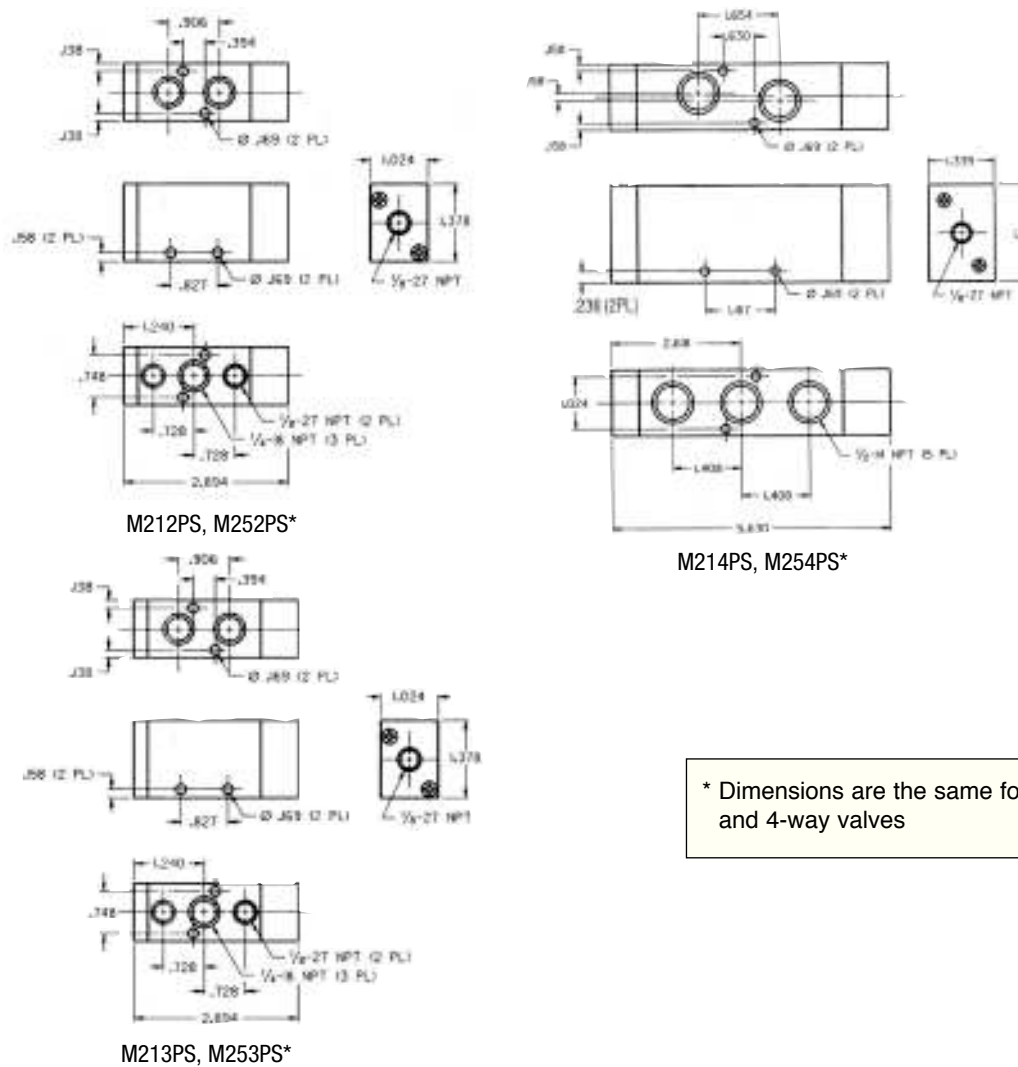

* Dimensions are the same for 3-way and 4-way valves

Dimensional Data

Solenoid

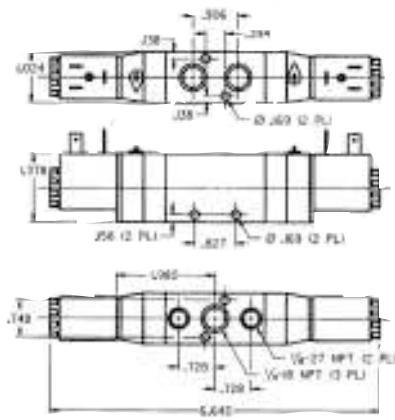

M212SD
M312SD

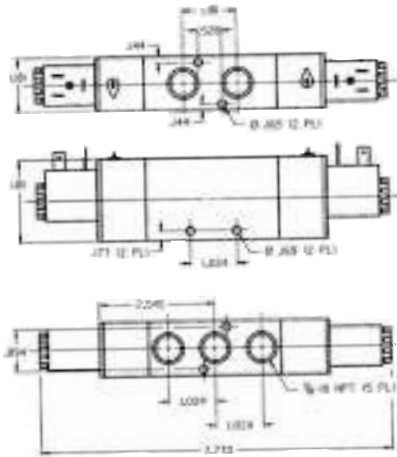

M213SD
M313SD

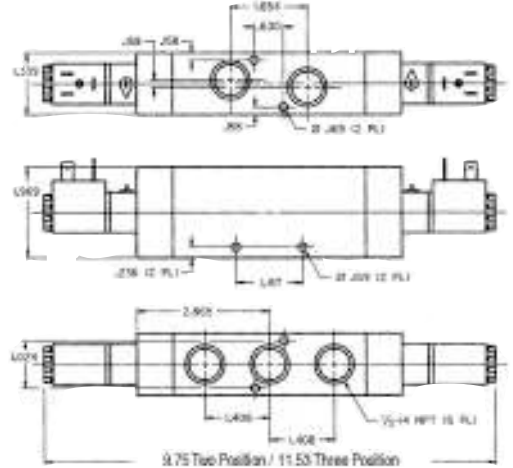

M214SD
M314SD

Pilot

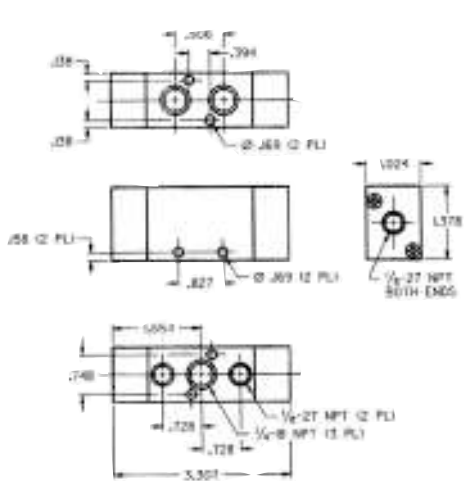

M212PD
M312PD

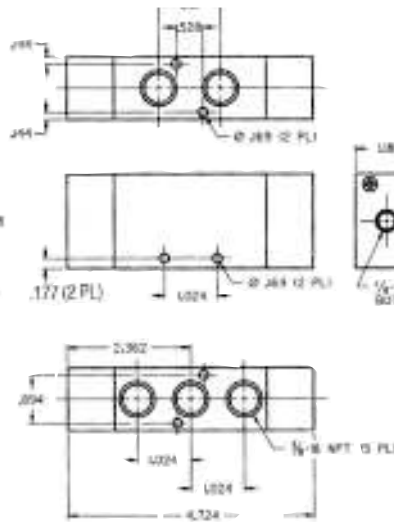

M213PD
M313PD

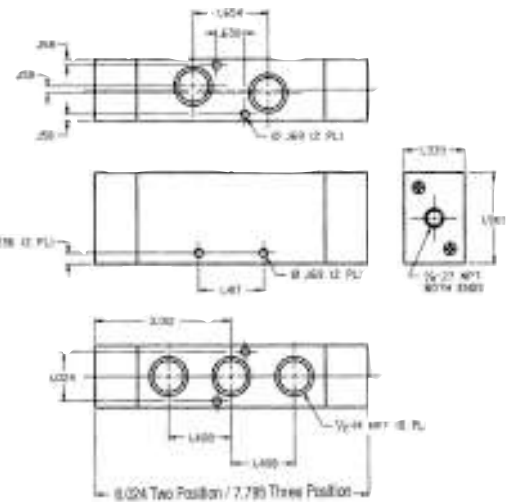

M214PD
M314PD

Features

Body Ported Valves

Compact, space saving design. Perfect for stand alone and remote valve applications. Ports have ISO identification. Sizes include 1/8", 1/4" and 3/8" NPT.

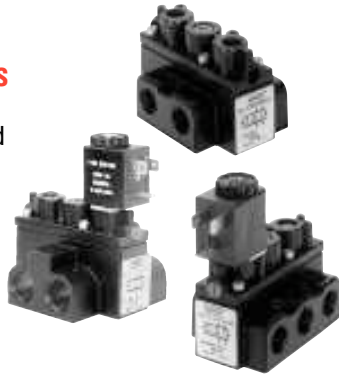

Subbase Valves

Replace valves easily! Simply remove three screws, lift off valve and replace. Math made simple! Add or subtract manifolds by removing an end plate and changing the valve stack as needed. No tie rods to make changing manifold lengths difficult. Port sizes of 1/8", 1/4", 3/8" and 1/2" with ISO port identifications. Subbase Valves use the same electrical coils and connectors as the ALPHA Body Ported Valve. Both End Plates can be used for common supplies and exhaust in high flow applications.

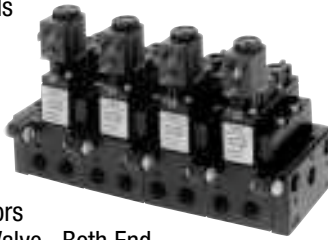

Stacking Valves

The lowest cost method of ganging valves, because it eliminates the manifold. Flip out design. Loosen the end plate cap screws to swing the valve up and out. No need to disassemble entire stack to replace one valve. Bodies stack on 1" centers. Circuits can be designed and mounted in a compact area. When stacked, ALPHA becomes a 4-way, 4-ported valve. 3/8" common end plate ports with 1/8" or 1/4" working ports in the valve body.



"Thin" Manifold Valves

Thin, 1" width means more valves in less space. Faster assembly than stacking style valves. 2, 4, 6, 8, and 10 station manifolds are available. Use optional blanking plates for odd-numbered stations. 1/4" (NPT) models, with 3/8" supply or exhaust ports. Speed controls install directly into manifold, cutting set-up time.

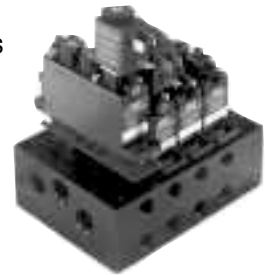

Versatile Design

- Available in Body Ported, Subbase, Stacking and "Thin" configurations.
- Alpha can be ordered as a two-position or three-position valve.
- 5-Year Warranty.
- Valve Body, End Plate and Manifold material is zinc.

Superb Performance

- ALPHA's bonded, precision ground spool resists wear & provides excellent shift response.
- Large air passages result in high flow characteristics. Listings detail Cv factor and maximum flow rates.

Numerous Control Options

- Control the valve one of five ways: Solenoid/Spring, Solenoid/Solenoid, Solenoid/Pilot, Pilot/Spring or Pilot/Pilot.
- External solenoid supply allows operation for vacuum service and low pressure applications. (Use kit No. 119306)
- Coils are UL and CSA Listed (Files: UL #MH13513; CSA #LR51090).

Performance Specifications

Pressure Range: Vacuum to 150 psi (10.2 bar)

Operating Medium: Compressed Air or inert gas

Lubrication: None Required

Filtration: 40 Micron recommended

Cycle Rate: 600 Cycles Per Minute

Temperature Rating: 0° to 180°F (-17° to 82°C)

Shift Pressures: 50 psi (3.4 bar) 2-Position Single Solenoid or Single Pilot, Spring Return.
20 psi (1.4 bar) 2-position double pilot or double solenoid.
60 psi (4.0 bar) 3-Position Double Solenoid or Double Pilot, Spring Centered.

Signal Response Time:

Double Pilot Actuator:	14 ms
Double Solenoid:	20 ms
Single Pilot (Pilot On)	19 ms
Single Pilot (Pilot Off)	26 ms
Single Solenoid (Energized)	22 ms
Single Solenoid (De-energized)	27 ms

Flow:

Body Ported

2-position 1/8" Ports = .9 Cv, 30 SCFM

2-position 1/4" Ports = 1.5 Cv, 50 SCFM

2-position 3/8" Ports = 1.7 Cv, 61 SCFM

3-position 1/8" Ports = .8 Cv, 27 SCFM

3-position 1/4" Ports = 1.4 Cv, 45 SCFM

3-position 3/8" Ports = 1.7 Cv, 61 SCFM

Subbase Valves:

1/8" Ports = 1.3Cv, 43 SCFM

1/4" Ports = 1.6 Cv, 54 SCFM

3/8" Ports = 1.6 Cv, 54 SCFM

1/2" Ports = 1.75 Cv, 57 SCFM

Stacking Valves:

2-position 1/8" Ports = 1.32 Cv, 43 SCFM

2-position 1/4" Ports = 1.9 Cv, 63 SCFM

3-position 1/8" Ports = 1.2 Cv, 39 SCFM

3-position 1/4" Ports = 1.7 Cv, 57 SCFM

"Thin" Valves:

1/4" Ports = 1.2 Cv, 39 SCFM

Ordering

A X X X XX - XXX - X

Alpha Series

Valve, Spool Type

Code	Description
2	2-Position, Urethane
3	3-Position, Urethane
8	3-Position, Viton (3 & 8 are Spring Centered, all ports blocked in neutral. Available only with PD or SD Actuators)
4	2-Position, Viton
7	3-Position, Urethane
9	3-Position, Viton (7 & 9 are Spring Centered, inlet ports blocked (cylinder ports open) in neutral. Available only with PD or SD Actuators)

Valve Body Styles

Code	Description
1	4-Way, Body Ported Valves
2	4-Way, Stacking Valves Order End Plates from menu on Page 22. Order Mounting Brackets from Page 22.
3	4-Way, Subbase Mounted Valves Order Subbase Manifolds from menu on Page 23.
4	4-Way, Alpha Thin Valves Order Alpha Thin Manifolds & Speed Control Kits from menus on Page 23.

Current Type

Code	Description
A	AC
D	DC
N	No Coil
L	Low Watt <small>(DC Only, 115 PSI Max.)</small>

Coil Voltage

Leave Blank if ordering Pilot Valves

Code	Description	Code	Description
000	No coil	024	24V AC/DC
005	5V DC	120	120V AC
012	12V AC/DC	240	240V AC

Actuator/Return*

Code	Description
*PS	Pilot/Spring
*PD	Pilot/Pilot
SS	Solenoid/Spring
SD	Solenoid/Solenoid
SP	Solenoid/Pilot

*Numbering ends here if a non-solenoid (PS or PD) valve is being selected.

Port Size

Code	Description
1	1/8" NPTF (#1 & #2 available on Body Ported
2	1/4" NPTF or on Stacking Valves)
3	3/8" NPTF (#3 available on Body Ported Valves only)
9	NONE (#9 used on Subbase or Alpha Thin Valves)

If coil option A, D or L is selected, a coil connector must be ordered. See Pg. 79 for coil & connector information. (Low Watt coils work only on valves with low watt option)

Ordering Examples

Body Ported Valve: A212SS-120-A
 "2" 2-Position Valve, Urethane Spool
 "1" 4-Way Body Ported Valve
 "2" 1/4" NPTF Ports
 "SS" Actuator-Solenoid, Return-Spring
 "120-A" 120 Volt Coil, AC Current

"Thin" Valve & Manifold: A449PS
 "4" 2-Position Valve, Viton Spool
 "4" 4-Way Alpha "Thin" Valve
 "9" 9 No NPTF Ports
 "PS" Actuator-Pilot, Return-Spring
"Thin" Manifold: 118605-4
 "11860X-X" Basic Manifold
 "5" 1/4" NPT Ports
 "-4" 4-Stations
 Manifold information on Page 23.

119306 External Supply Conversion Kit, Page 22. Use when supply pressure is under 50 PSI or vacuum is used.

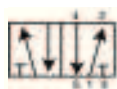

4-Way, 2-Position

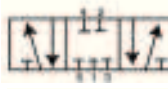

4-Way, 3-Position, all ports blocked in neutral

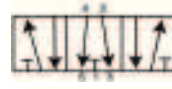

4-Way, 3-Position, cylinder ports open, inlet port blocked

Accessories for Alpha Stacking Valves

End Plates and Isolator Plates

- MKN** One MKN Kit is required to stack 1-to-6 Valves without Isolator Plates. Each contains 2 End Plates, 2 Cap Screws and 1 Gasket.
- MKP** One MKP Kit is required to stack 7-to-12 Valves without Isolator Plates, or 1-to-12 Valves with an Isolator Plate. Each contains 2 End Plates, 2 Cap Screws and 1 Gasket.
- PTN** Isolator Plate. Blocks Supply and Exhaust Ports. Gasket Included.
- PEN** Isolator Plate. Blocks Exhaust Ports. Gasket Included.
- PPN** Isolator Plate. Blocks Supply Ports. Gasket Included.

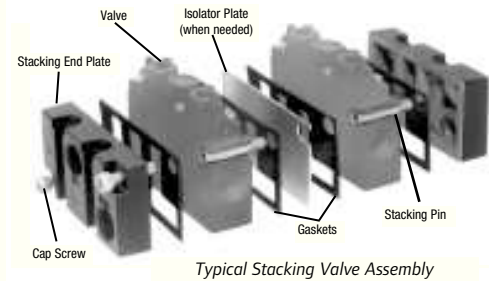

Typical Stacking Valve Assembly

Mounting Brackets

Kits include both Brackets and hardware to mount valve stacks to the brackets.

- 116710** Tie Bold Kit
- 116807** Long L - 7" long
- 116808** Short L - 3.75" long
- 116809** Tall Z - 6" high
- 117987** Short Z - 3" high



116808 Short L



116809 Tall Z

Dimensional Data

Mounting Brackets

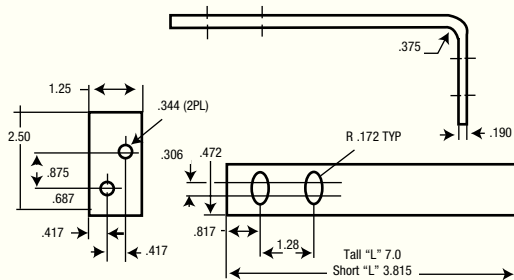

"L" Brackets #116807 and 116808

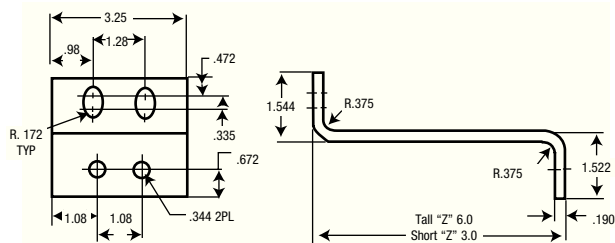

"Z" Brackets #116809 and 117987

Accessories

Breather Vent, External Supply Plug Kit

116464 Solenoid Breather Vent 10-32 Thread Size.

119306 External Solenoid Supply Plug Kit

Changes ALPHA valves from internal to external solenoid air source.

Step #1: Remove all air supply sources, remove sealing plug. Figure 1.

Step #2: Install separator plug by threading plug into valve body with a flat-head screwdriver. See Figure 2.

Step #3: Connect the external pilot air supply to the valve with an 1/8" NPT connector.

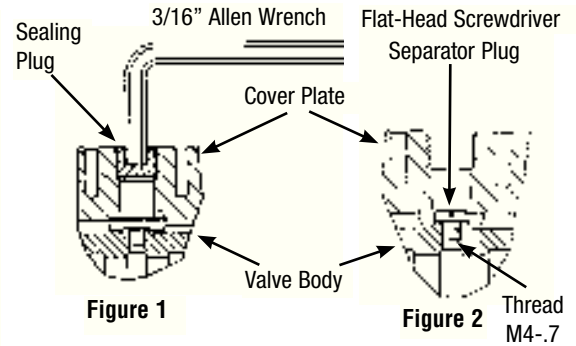

Alpha "Thin" Valves

Alpha Thin Manifolds

11860X - X

Port Size		Number of Stations	
Code	Description	Code	Description
5	1/4" NPT	2	2 Station
		4	4 Station
		6	6 Station
		8	8 Station
		10	10 Station

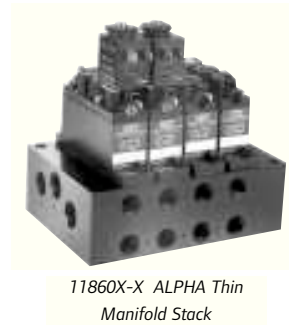

Alpha Thin Speed Controls

Control speed directly from the manifold. Kits allow you to control only the cylinder direction needed.

119230 Kit controls Port 2 exhausting to Port 3.

119231 Kit controls Port 4 exhausting to Port 5.

118618 Includes both 119230 and 119231 control kits.

118612 Station blanking kit.

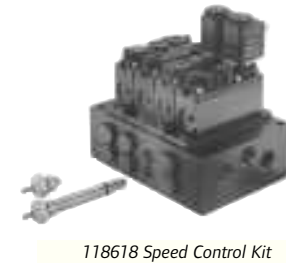

Subbase Valves

Manifold & End Plate Kits

- Manifold Kits are required when ordering Sub-base valves.
- One End Plate Kit is needed for each valve stack.
- Manifold Kits include the Manifold, one Gasket and two Screws.
- End Plate Kits include two End Plates, one Gasket and two Screws.

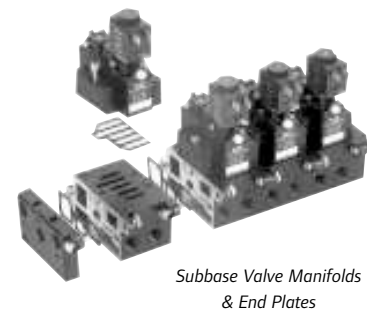

Port Size	Manifold Kit	End Plate Kit
1/8"	115422-1	116904-1
1/4"	115455-1	116916-1
3/8"	116862-1	116917-1
1/2"	116899-1	116926-1

Dimensional Data Dimensions given in Inches and (Millimeters)

1/8" and 1/4" Body Ported Valves

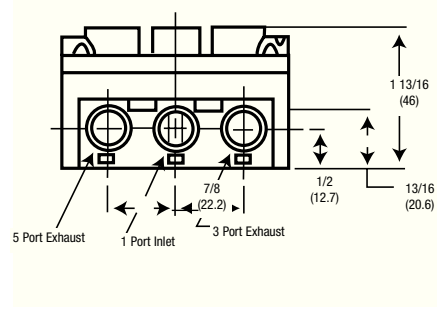
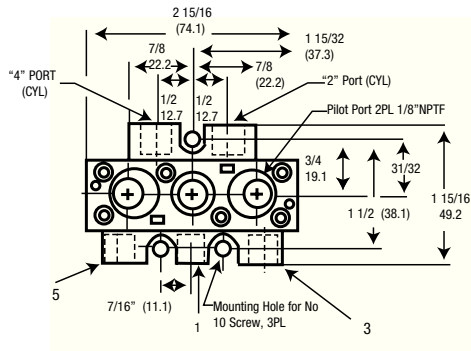
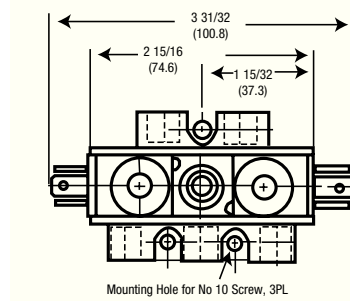
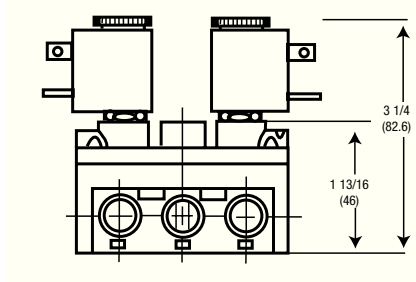

3/8" Body Ported Valves

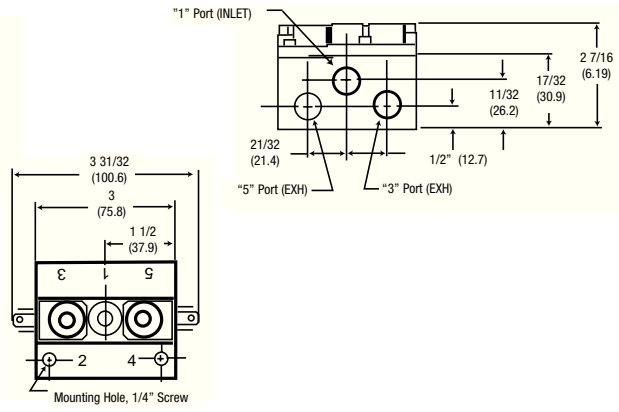
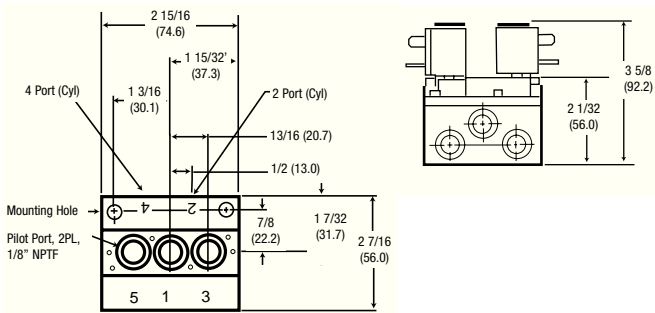

Stacking Valves

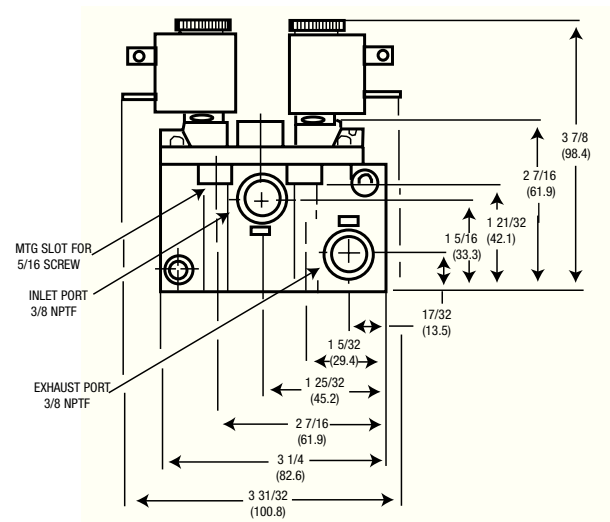
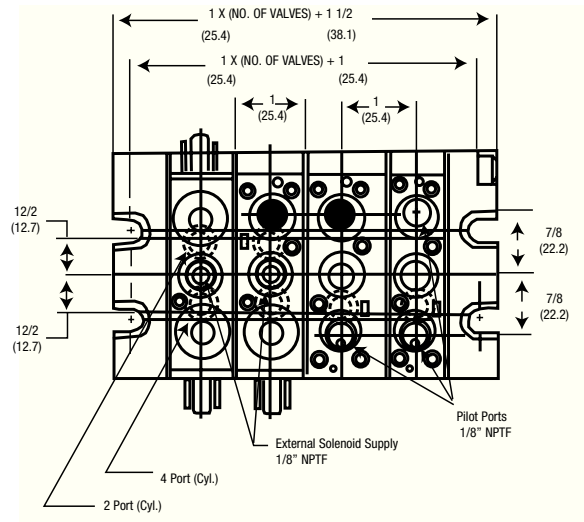

Dimensional Data

Subbase Valves with 1/8" or 1/4" Cylinder Ports

Dimensions given in Inches and (Millimeters)

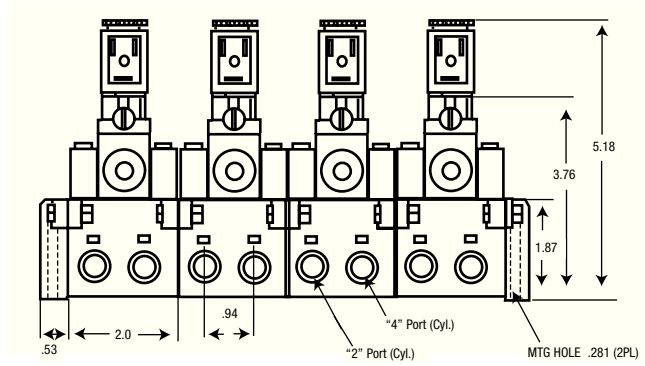
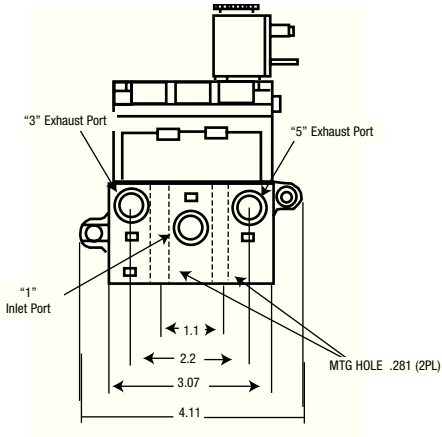

Subbase Valves with 3/8" or 1/2" Cylinder Ports

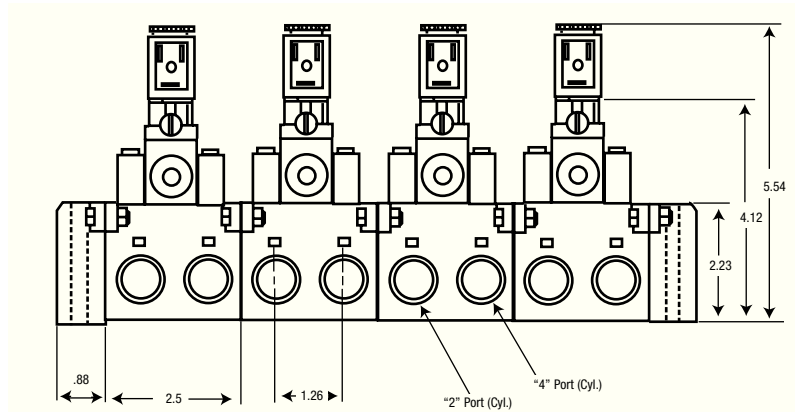
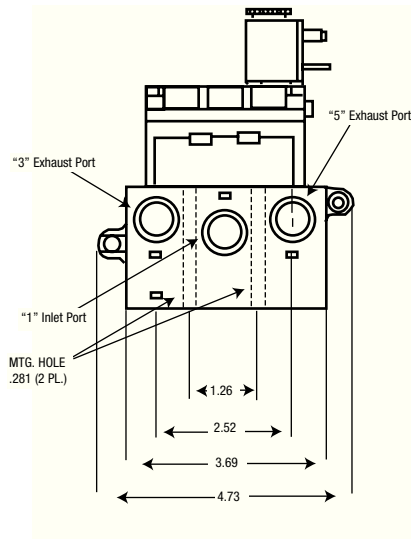

Thin Manifolds with 3/8" or 1/4" Cylinder Ports

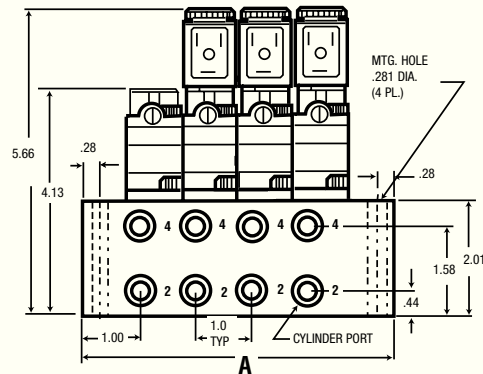
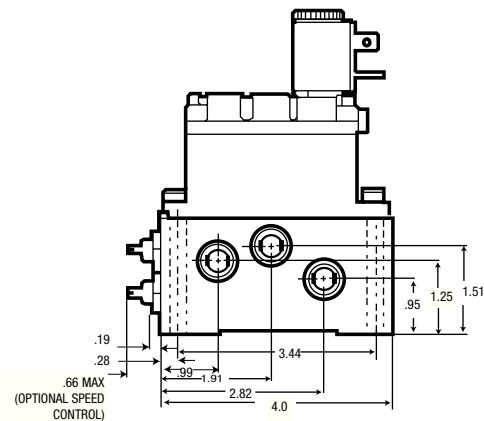

NO. OF STATIONS	A
2	3.57
4	5.57
6	7.57
8	9.57
10	11.57

Features

- Push-In Fitting Standard: 5/32" outlet, 1/4" inlet on 10mm
1/4" outlet, 3/8" inlet on 15mm
- High speed responsiveness and flow
- Less than 12ms response time
- Low power consumption
- Compact and High Flow Rate
- Plug In Valve
 - No wiring needed for installation
- Modular Type Manifold
- Each base is installed individually, so adding or removing another base is simple.
- Wiring Method
 - Usage of D-Sub connector, or Flat Cable connector, Substitute the D-Sub connector and Flat Cable connector with ease
- Safety
 - RoHS, UL, (In process of receiving CE mark.)
- Easy to add SUP/EXH Blocks
 - There is no limit to the addition of SUP/EXH Blocks
 - It can be applied for dual pressure & back pressure applications.

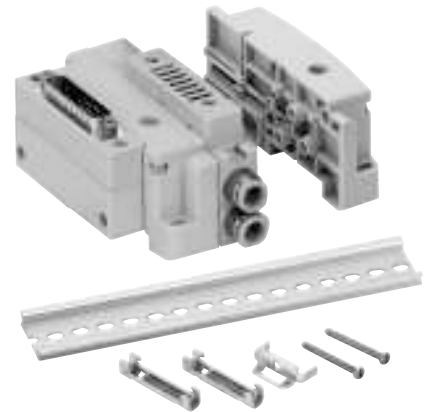
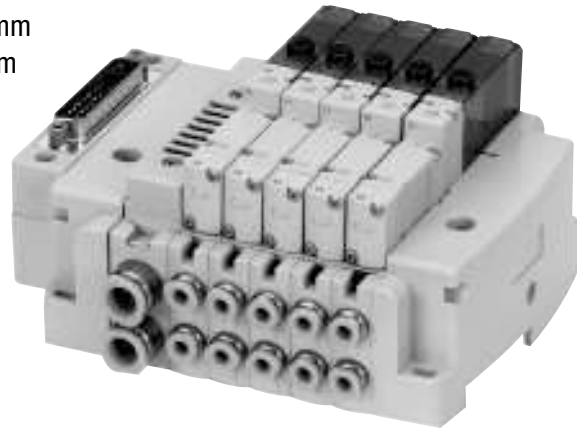

Manifold Kit

Performance Specifications

Operating Pressures

- **2-Position Single** 21.8 to 101.5 p.s.i. (1.5 -7.0 bar)
- **2-Position Double** 14.5 to 101.5 p.s.i. (1.0 -7.0 bar)
- **3-Position Double** 29.0 to 101.5 p.s.i.(2.0 -7.0 bar)

Operating Medium

Compressed Air only

Temperature

23° to 122° F (-5° tp 50° C)

Coil Voltage

12, 24 VDC (± 10%)

Power Consumption

0.85 Watts

Flow 10mm = 0.22 Cv (4.0mm²), 15mm = 0.53 Cv (9.6mm²)

Ordering

Valve Action	10mm Valve on Manifold	10mm Valve Only	15mm Valve on Manifold	15mm Valve Only
4-Way 2 Position				
Single Solenoid 12 VDC	TP12C4S-012-M	TP12C4S-012-V	TP22C7S-012-M	TP22C7S-012-V
Single Solenoid 24 VDC	TP12C4S-024-M	TP12C4S-024-V	TP22C7S-024-M	TP22C7S-024-V
Double Solenoid 12 VDC	TP12C4D-012-M	TP12C4D-012-V	TP22C7D-012-M	TP22C7D-012-V
Double Solenoid 24 VDC	TP12C4D-024-M	TP12C4D-024-V	TP22C7D-024-M	TP22C7D-024-V
4-Way 3 Position (all ports blocked)				
Double Solenoid 12 VDC	TP13C4D-012-M	TP13C4D-012-V	TP23C7D-012-M	TP23C7D-012-V
Double Solenoid 24 VDC	TP13C4D-024-M	TP13C4D-024-V	TP23C7D-024-M	TP23C7D-024-V
Manifold Kits		10mm	15mm	
25 Pin Manifold Kit	114829		114834	
26 Pin Manifold Kit	114836		114841	
Supply/Exh Block	114840		114842	
Din Rail	114839		114843	



Valve on Manifold

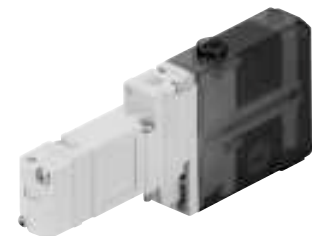

Valve Only

Manifold Kit includes: 2-End Caps, 1-Supply/Exh block and 1-Din Rail (10 station)

Assembly Instructions

- 1 End Plate
- 2 Supply Exhaust Block
- 3 Base
- 4 Valve
- 5 End Plate
- 6 Locking Clip
- 7 DIN Rail
- 8 DIN Rail Screw
- 9 "P" Port
- 10 "R" Port
- 11 "B" Port
- 12 "A" Port

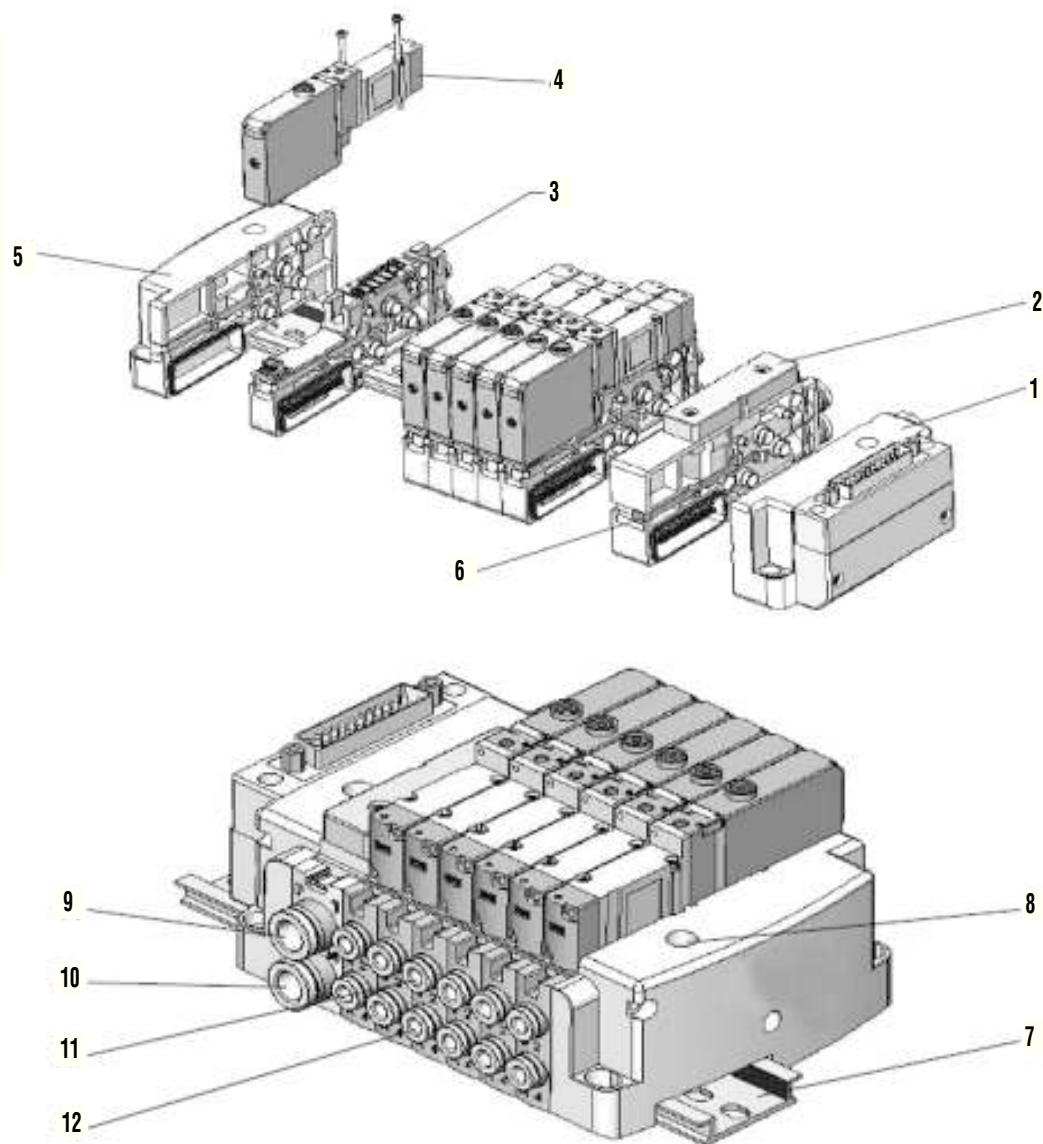

1. Before assemble, check for proper alignment of five "O" rings and (7) gasket.
2. The (8) metal locking clip should be fully extended out before assembling.
3. Position the (4) valves in the desired location in the stack. Align pins with sockets and push together. Slide the (8) metal locking clip into place to lock the 2 units together. Continue this procedure until all valve manifolds have been connected. Manifold Kit Attachment includes: two (1 and 6) end plates, (2) supply / exhaust block and (9) 1 - 10 DIN rail.
4. Attach the (2) supply / exhaust block to the end of the stack and lock into place using the (8) metal locking clip.
5. Align the (1) end plate to the (2) supply / exhaust block and lock into place using the (8) metal locking clip.
6. Align the (6) end plate to the opposite end and lock into place using the (8) metal locking clip.

7. Slide the (9) DIN rail onto the underside of the valve stack into the desired location. Tighten one (10) screw on top of each end plate. NOTE: (9) DIN rails may be cut to size.

To replace a (4) valve unit without disturbing the valve stack: Loosen and remove two (5) screws located on top of valve. Pull up on (4) valve to remove. Align the electrical connection on the end of the valve with the manifold socket. Align and tighten (4) screws.

NOTE: Ten (4) valves per stack maximum.
The (8) metal locking clip must be extended out before assembly to prevent bending of clip.
Voltages cannot be mixed on the valve stack

Valve Circuits

1. Common
2. Solenoid "A"
3. Solenoid "B"
4. 1st Station
5. 2nd Station
6. 3rd Station
7. 11th Station
8. 12th Station

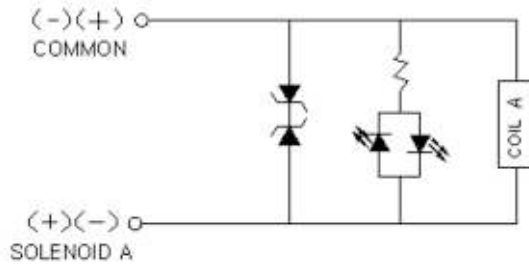

<Single Circuits>

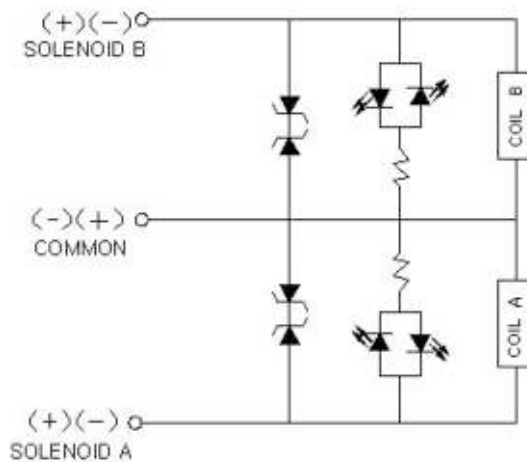

<Double Circuits>

Manifold Electrical Arrangement

D_Sub Connector type

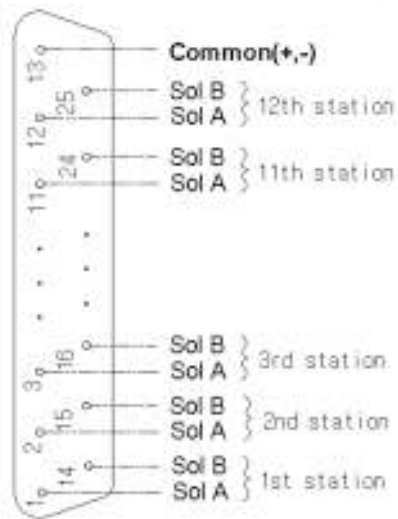

Flat Cable Connector type

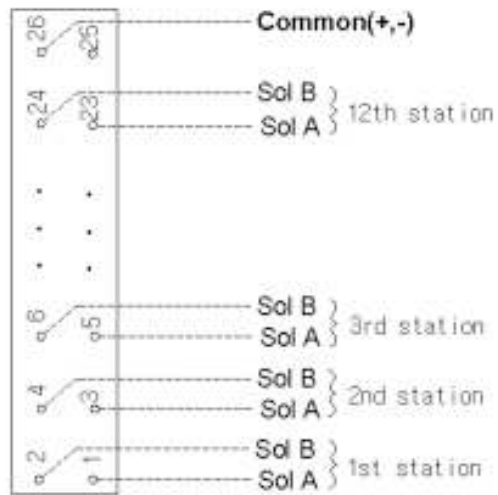

Dimensional Data, 10mm*

25 Pin Sub-D Connector

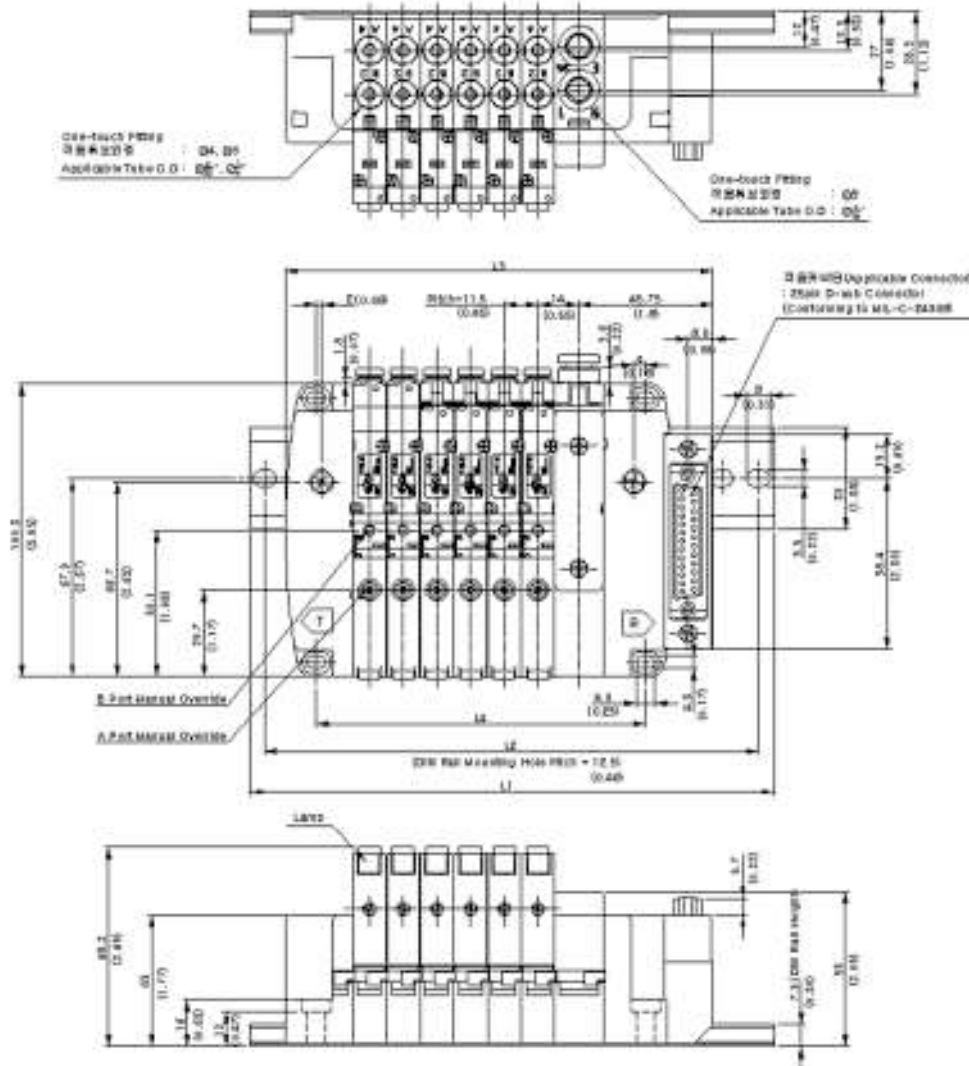

L ⁿ	2	3	4	5	6	7	8	9	10	11	12
L1	5.83 (148)	6.32 (160.5)	6.81 (173)	7.30 (185.5)	7.80 (198)	8.29 (210.5)	8.78 (223)	9.27 (235.5)	9.76 (248)	10.26 (260.5)	10.75 (273)
L2	5.41 (137.5)	5.91 (150)	6.40 (162.5)	6.89 (175)	7.38 (187.5)	7.87 (200)	8.37 (212.5)	8.86 (225)	9.35 (237.5)	9.84 (250)	10.33 (262.5)
L3	3.94 (100)	4.39 (111.5)	4.84 (123)	5.30 (134.5)	5.75 (146)	6.20 (157.5)	6.65 (169)	7.11 (180.5)	7.56 (192)	8.01 (203.5)	8.46 (215)
L4	2.62 (66.5)	3.07 (78)	3.52 (89.5)	3.98 (101)	4.43 (112.5)	4.88 (124)	5.33 (135.5)	5.79 (147)	6.24 (158.5)	6.69 (170)	7.15 (181.5)

L3, L4 Sup/Exh Block: 0.65 (16.5) x n

*Contact factory for dimensional data on 15mm valves

Dimensional Data

26 Pin Flat Cable Connector

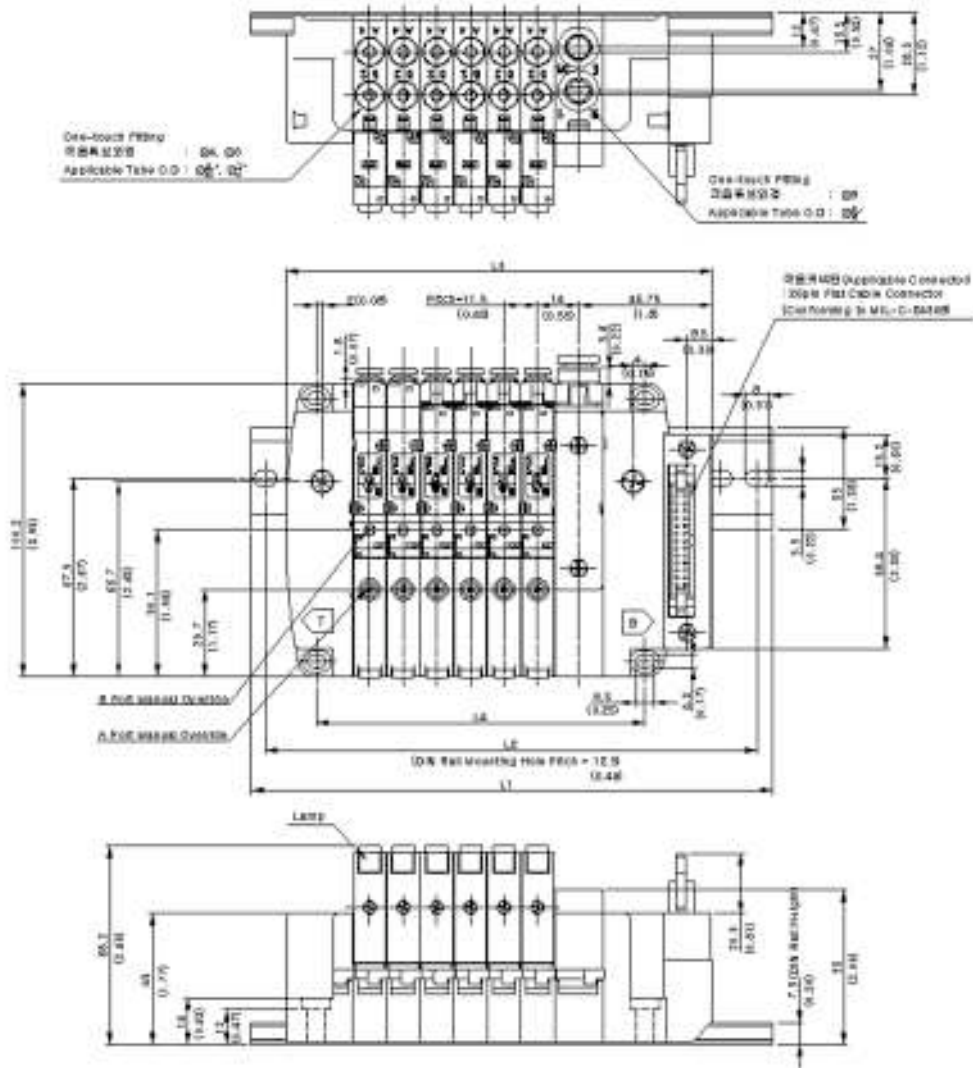

L \ n	13	14	15	16	17	18	19	20	21	22	23	24
L1	11.24 (285.5)	11.73 (298)	12.22 (310.5)	12.72 (323)	13.21 (335.5)	13.71 (348)	14.19 (360.5)	14.69 (373)	15.18 (385.5)	15.67 (398)	16.16 (410.5)	16.65 (423)
L2	10.83 (275)	11.32 (287.5)	11.81 (300)	12.30 (312.5)	12.80 (325)	13.29 (337.5)	13.78 (350)	14.27 (362.5)	14.76 (375)	15.26 (387.5)	15.75 (400)	16.24 (412.5)
L3	8.92 (226.5)	9.37 (238)	9.82 (249.5)	10.28 (261)	10.73 (272.5)	11.18 (284)	11.63 (295.5)	12.09 (307)	12.54 (318.5)	12.99 (330)	13.44 (341.5)	13.90 (353)
L4	7.60 (193)	8.05 (204.5)	8.50 (216)	8.96 (227.5)	9.41 (239)	9.86 (250.5)	10.31 (262)	10.77 (273.5)	11.22 (285)	11.67 (296.5)	12.13 (308)	12.58 (319.5)

Features

Valve Performance Features

- CAT Series Valves are available as single station units, bar manifold or assembled as a stack.
- CAT Series valves are suitable for air or inert gas.
- Plugging the exhaust port allows single station valves to be plumbed as 2-way valves. See page 34 to order the optional exhaust port plug.
- CAT Series valves are available with a variety of coil options. See Pg. 80.
- Class F coils are rated for 100% duty cycle.

CAT Series Valve Features and Benefits

- Quick change coil can be easily interchanged or replaced. Simply remove the top nut, slide off the coil and replace it with a new coil.
- The coil accepts DIN-style connectors, or automotive spade type connections. This helps reduce installation time and provides a secure electrical hook-up. See page 80.
- When mounted individually, the coil can be rotated to face one of four ways. As a stack, the coils can be mounted in two directions.
- Coils are UL-listed and comply with CSA standards. UL file #MH13513, CSA File #LR51090. NEMA 4 option available.



Single CAT Series Valve



Two Valve CAT Series Stack



High Flow Cat Valve

Performance Specifications

- Pressure Range:** 0 to 115 PSI Low Watt
Pressure Range: 0 to 150 PSI (10.4 bar)
Temperature Rating: 0° to 122°F (-17° to 50°C)
Flow:

1/8" Individual, Bar Manifold and Stacking Valves:

- CAT33P: Cv = .062 (2.2 SCFM), Seat Orifice .051, Stem .070
 CAT33S: Cv = .048 (1.8 SCFM), Seat Orifice .051, Stem .070
 CAT44P: Cv = .056 (2.0 SCFM), Seat Orifice .039, Stem .051
 CATXXB: Cv = .062 (2.2 SCFM), Seat Orifice .051, Stem .070

Operating Medium: Compressed Air

Response Time: 5 - 9 ms



Six-Station Cat Valve Bar Manifold

Ordering

1/8" Individual and Stacking Valves

Model Number:	Port Size	Valve Function	Body Style
CAT33P-XXX-X	1/8"	Non-Passing	Ported
CAT33S-XXX-X	1/8"	Non-Passing	Stackable
CAT44P-XXX-X	1/8"	Passing	Ported

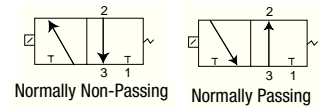

To stack CAT Series valves, tie-rod mounting kits are required. Order kits separately from the menu below.

Coil Options

Code	Voltage	Current	Code	Voltage	Current
000-N	Valve with <i>No</i> Coil		024-D	24 Volt	DC
005-D	5 Volt	DC	120-A	120 Volt	AC
012-A	12 Volt	AC	240-A	240 Volt	AC
012-D	12 Volt	DC	*005-L	5 Volt Low Watt	DC
024-A	24 Volt	AC	*012-L	12 Volt Low Watt	DC
			*024-L	24 Volt Low Watt	DC

If coil option A or D is selected, a coil connector must be ordered. See Pg. 79 for coil & connector information.

* Available on CAT33P-XXX-L & CAT33S-XXX-L only.

Accessories

Exhaust Plug

59632-1 (10-32 Thread)

Plugs exhaust port to convert normally non-passing 3-way valve to 2-way.

NOTE: To make a normally passing 3-way valve to a 2-way valve requires a DC plug.

Stacking Tie-Rod Kits

116345-2 2 Valve Stack

116345-3 3 Valve Stack

116345-4 4 Valve Stack

116345-5 5 Valve Stack

116345-6 6 Valve Stack

Tie-Rod Kits include tie rods, nuts, o-rings and a plug.

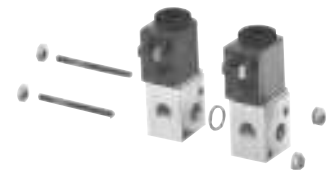

CAT Series Valve Stack and 116345-X Stacking Kit

Dimensional Data

Dimensions given in Inches and (Millimeters)

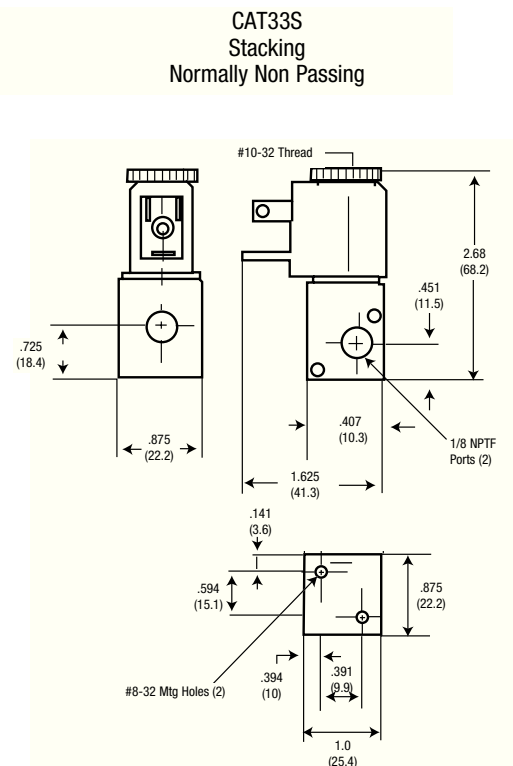
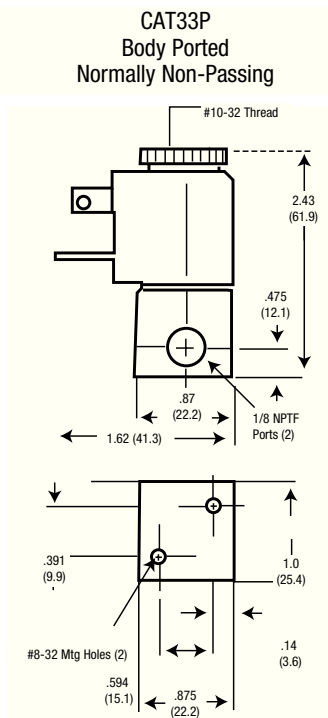
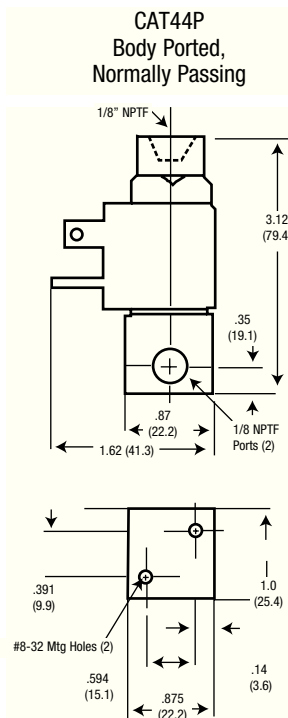

High Flow Cat Valve

Model Number:	Port Size	Valve Function	Body Style
CAT66P-XXX-X*	1/4"	Normally Closed	Ported
CAT77S-XXX-X*	1/4"	Normally Closed	Stacking
CAT88P-XXX-X*	1/4"	Normally Open	Ported

* Coil Voltage

012-D	12 Volt DC
120-A	120 Volt AC
024-D	24 Volt DC
000-N	No Coil
*012-L	Low Watt DC
*024-L	Low Watt DC

*Available on normally closed valves only.



High Flow Cat Valve

Performance Specifications

Pressure Range:	0 to 150 PSI
Temperature Rating:	0° to 122° F
Operating Medium:	Compressed Air
High-Flow Valves:	CAT66P: Cv = .2 (6.9 SCFM)
	CAT77S: Cv = .2 (6.9 SCFM)
	CAT88P: Cv = .2 (6.9 SCFM)

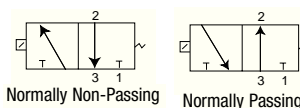

Normally Non-Passing

Normally Passing

To stack CAT Series valves, tie-rod mounting kits are required. Order kits separately from the menu below.

Dimensional Data

High Flow Cat Valve

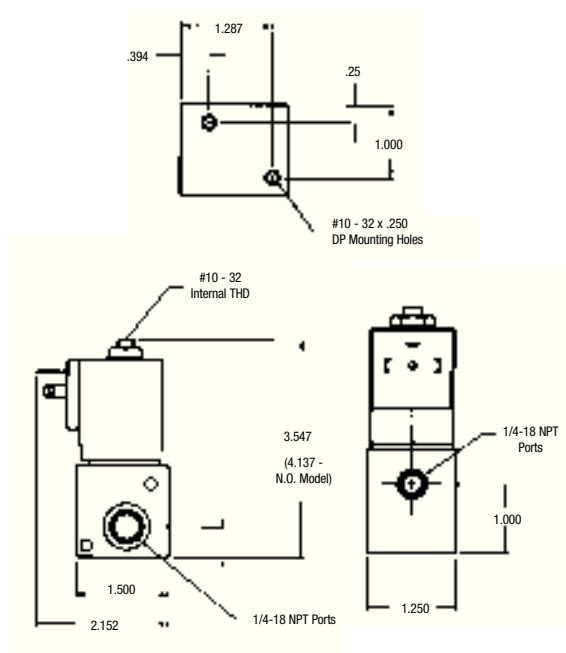

Accessories

High-Flow Tie-Rod Kits

Stacking Tie-Rod Kits

119698-2	(2 Stations)
119698-3	(3 Stations)
119698-4	(4 Stations)
119698-5	(5 Stations)
119698-6	(6 Stations)
119698-7	(7 Stations)

Connector

CDW-30	30-mm connector with wire.
CSN-30	30-mm connector, strain relief.
CHW-30	30-mm connector, molded cable.
119690-XX	See Page 79 for Coil information.

Ordering

Cat Valve Bar Manifold

C A T X X B - X X X - X

No. of Stations		Coil Options			Code Voltage Current		
02	10	Code	Voltage	Current	Code	Voltage	Current
03	11	000-N	Valve with <i>No</i> Coil		240-A	240 Volt	AC
04	12	005-D	5 Volt	DC	005-L	5 Volt Low Watt	DC
05	13	012-A	12 Volt	AC	012-L	12 Volt Low Watt	DC
06	14	012-D	12 Volt	DC	024-L	24 Volt Low Watt	DC
07	15	024-A	24 Volt	AC			
08	16	024-D	24 Volt	DC			
09		120-A	120 Volt	AC			
		120-D	120 Volt	DC			

See Page 79 for Connectors and other Coil options.

Dimensional Data Dimensions given in Inches and (Millimeters)

Cat Valve Bar Manifold

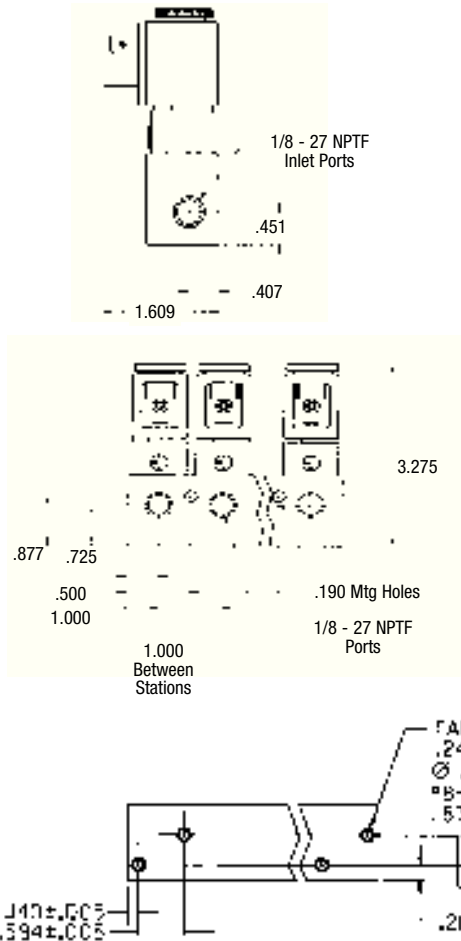

Six-Station Cat Valve Bar Manifold

Miniature 3-Way and 4-Way Valves Ordering Information:

Model	Description
P114400	END PLATE FOR 3-WAY OR 4-WAY VALVE STACK
114806	MOUNTING BRACKET FOR INLINE VALVES
114807	ISOLATOR PLUG KIT FOR STACKING VALVES
CSN-MICRO	CONNECTOR, STRAIN RELIEF
P251SS-012-D	3-WAY BODY PORTED, LEAD WIRE, 12 DC
P251SS-012-E	3-WAY BODY PORTED, PLUG-IN, 12 DC
P251SS-024-D	3-WAY BODY PORTED, LEAD WIRE, 24 DC
P251SS-024-E	3-WAY BODY PORTED, PLUG-IN, 24 DC
P251SS-120-A	3-WAY BODY PORTED, LEAD WIRE, 120 AC
P251SS-120-B	3-WAY BODY PORTED, PLUG-IN, 120 AC
P261SS-012-D	3-WAY STACKING, LEAD WIRE, 12 DC
P261SS-012-E	3-WAY STACKING, PLUG-IN, 12 DC
P261SS-024-D	3-WAY STACKING, LEAD WIRE, 24 DC
P261SS-024-E	3-WAY STACKING, PLUG-IN, 24 DC
P261SS-120-A	3-WAY STACKING, LEAD WIRE, 120 AC
P261SS-120-B	3-WAY STACKING, PLUG-IN, 120 AC
P211SS-012-D	4-WAY BODY PORTED, LEAD WIRE, 12 DC
P211SS-012-E	4-WAY BODY PORTED, PLUG-IN, 12 DC
P211SS-024-D	4-WAY BODY PORTED, LEAD WIRE, 24 DC
P211SS-024-E	4-WAY BODY PORTED, PLUG-IN, 24 DC
P211SS-120-A	4-WAY BODY PORTED, LEAD WIRE, 120 AC
P211SS-120-B	4-WAY BODY PORTED, PLUG-IN, 120 AC
P211SC-012-D	4-WAY BODY PORTED W/SPEED CONTROL, LEAD WIRE, 12 DC
P211SC-012-E	4-WAY BODY PORTED W/SPEED CONTROL, PLUG-IN, 12 DC
P211SC-024-D	4-WAY BODY PORTED W/SPEED CONTROL, LEAD WIRE, 24 DC
P211SC-024-E	4-WAY BODY PORTED W/SPEED CONTROL, PLUG-IN, 24 DC
P211SC-120-A	4-WAY BODY PORTED W/SPEED CONTROL, LEAD WIRE, 120 AC
P211SC-120-B	4-WAY BODY PORTED W/SPEED CONTROL, PLUG-IN, 120 AC
P221SS-012-D	4-WAY STACKING, LEAD WIRE, 12 DC
P221SS-012-E	4-WAY STACKING, PLUG-IN, 12 DC
P221SS-024-D	4-WAY STACKING, LEAD WIRE, 24 DC
P221SS-024-E	4-WAY STACKING, PLUG-IN, 24 DC
P221SS-120-A	4-WAY STACKING, LEAD WIRE, 120 AC
P221SS-120-B	4-WAY STACKING, PLUG-IN, 120 AC
P221SC-012-D	4-WAY STACKING W/SPEED CONTROL, LEAD WIRE, 12 DC
P221SC-012-E	4-WAY STACKING W/SPEED CONTROL, PLUG-IN, 12 DC
P221SC-024-D	4-WAY STACKING W/SPEED CONTROL, LEAD WIRE, 24 DC
P221SC-024-E	4-WAY STACKING W/SPEED CONTROL, PLUG-IN, 24 DC
P221SC-120-A	4-WAY STACKING W/SPEED CONTROL, LEAD WIRE, 120 AC
P221SC-120-B	4-WAY STACKING W/SPEED CONTROL, PLUG-IN, 120 AC



3-Way Body Ported



4-Way Body Ported



4-Way Body Ported with Speed Controls



3-Way and 4-Way Stacking Valves



114806 Mounting Bracket

Kit is designed for use with both 3-Way and 4-Way valves. Kit consists of a bracket, two #6-32 screws, and two nuts.



P114400 End Plate Kit

Kit consists of two end plates, two o-rings, and two bolts. One kit required for each valve stack. Can be used for 3-Way or 4-Way valves, or any combination of valves.



CSN-MICRO Connector

Plug-in DIN type connector conforms to Industrial Micro Type C. Order separately.

114807 Isolator Plug Kit

Kit consists of two plugs. Plugs can be used on stacking valves to convert 4-ways to 3-ways, or 3-ways to 2-ways. Also can be used to provide multiple pressures to a valve stack.

3-Way Valves

- Quick Response
- Direct Acting/Single Solenoid
- Non-Locking Manual Override
- Continuous Duty Coil
- 1/8" NPT
- 2-Position/Spring Return
- Can be used as a Diverter or Selector Valve

4-Way Valves

- Quick Response
- Can be used in a variety of 2-, 3-, and 4-Way functions
- Direct Acting/Single Solenoid
- Non-Locking Manual Override
- Continuous duty Coil
- 1/8" NPT
- 2-Position/Spring Return
- Optional Built-In Dual Flow Controls

Performance Specifications:

Port Size-NPT	1/8" NPT
Media	Air or Inert Gas
Operating Pressure	3-Way, 0 to 125 PSI 4-Way, Vac to 125 PSI
Ambient Temperature Range	32 to 125 F (0 to 50 C)
Cv Factor	.144
Coil Rated Voltage	120VAC (50/60Hz); 12, 24 VDC
Allowable Voltage Fluctuation	+ or - 10% of Rated Voltage
Coil Insulation Type	Class B Rated, 100% Duty Cycle
Power Consumption	DC 4.5 Watts
Electrical Entry	24" Lead Wire (22 AWG) Plug-In DIN Connector (Industrial Micro Type C)
Manual Override	Yes, Top of Coil, Non-Locking
Materials	Seals; Buna-N, Coil: Acetal Body; Aluminum, Brass and Stainless
Response Time (On/Off)	.012/.010 (DC), .012/.020 (AC) Sec.
Max. Cycle Rate	2700 (DC), 1875 (AC)
SCFM @ 100 PSIG	>10
Leak Rate (Max. Allowed)	4cc/Min. @ 100 PSIG
Lubrication	None Required, Factory Pre-Lubed
Weight	3-Way; .26 lbs (116g) 4-Way; .28 lbs. (128g)

Dimensional Data

4-Way Body Ported

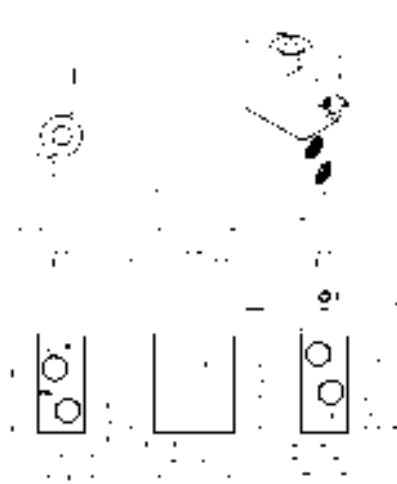

3-Way Body Ported

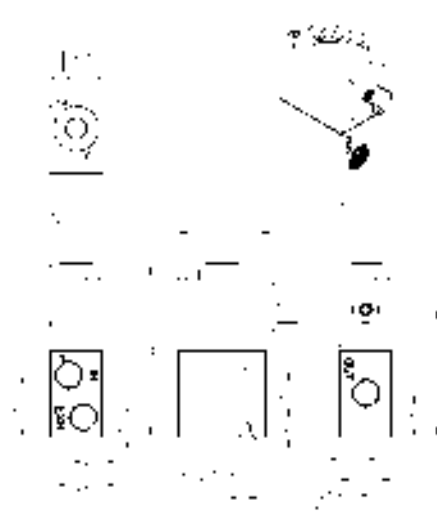

Stacking Valves



2-Way Direct Acting Solenoid Valves

- Valves are direct acting normally closed for fast response and are excellent for low operating pressure applications.
- Die-cast brass body, stainless steel stem and buna-n diaphragm provide excellent durability.
- Suitable for use with water, air, lightweight oil, liquid gas and vacuum*.
- Available with 12 VDC, 24 VDC, AND 120 VAC coils.

TB011B-XXX-X

Port Size: 1/8" NPT
 Orifice: 1.2 mm, 3/64"
 Cv: 0.1, SCFM: 3
 Pressure Range: AC = 120 PSI
 DC = 100 PSI



TB022B-XXX-X

Port Size: 1/4" NPT
 Orifice: 2.3 mm, 3/32"
 Cv: 0.18, SCFM: 5
 Pressure Range: AC = 120 PSI
 DC = 100 PSI



TB034B-XXX-X

Port Size: 3/8" NPT
 Orifice: 8.0 mm, 5/16"
 Cv: 1.0, SCFM: 28
 Pressure Range: AC = 140 PSI
 DC = 100 PSI



TB035B-XXX-X

Port Size: 3/8" NPT
TB045B-XXX-X
 Port Size: 1/2" NPT
 Orifice: 13 mm, 33/64"
 Cv: 4.5, SCFM: 126
 Pressure Range: AC = 120 PSI
 DC = 100 PSI



TB066B-XXX-X

Port Size: 3/4" NPT
 Orifice: 20 mm, 25/32"
 Cv: 8.6, SCFM: 240
 Pressure Range: AC = 120 PSI
 DC = 85 PSI



TB087B-XXX-X

Port Size: 1" NPT
 Orifice: 25 mm, 1"
 Cv: 11, SCFM: 308
 Pressure Range: AC = 100 PSI
 DC = 70 PSI

Technical Data

Temperature Range: 0 - 180 F
 Duty Cycle: 100 %
 Power consumption: 22 VA
 Response Time: 30 ms

Ordering Information

Replace XXX-X with voltage needed
 000-N = No Coil
 012-D = 12 VDC
 024-D = 24 VDC
 024-A = 24 VAC
 120-A = 120 VAC
 (Viton Seals Available, Consult Factory)

NOTE: All valves are shown with a CSN (1/8" and 1/4" ports) or CSN-30 (3/8" & larger) connector. Connector is to be ordered separately. See page 79 for ordering information.

* Vacuum operation only available with TB011B-X, TB022B-X and TB034B-X.

2-Way Solenoid/Pilot Acting Valves

- Valves are internally piloted, normally closed and excellent for high flow applications.
- Die-cast brass body, stainless steel stem and buna-n diaphragm provide excellent durability.
- Suitable for use with water, air, lightweight oil, and liquid gas.
- Available in 12 VDC, 24 VDC, AND 120 VAC coils.



TB03EB-XXX-X
 Port Size: 3/8" NPT
 Orifice: 13 mm, 33/64"
 Cv: 4.5, SCFM: 126
 Pressure Range: 10-150 PSI



TB04EB-XXX-X
 Port Size: 1/2" NPT
 Orifice: 13 mm, 33/64"
 Cv: 4.5, SCFM: 126
 Pressure Range: 10-150 PSI



TB06HB-XXX-X
 Port Size: 3/4" NPT
 Orifice: 25 mm, 1"
 Cv: 12, SCFM: 336
 Pressure Range: 10-150 PSI

TB08HB-XXX-X
 Port size: 1" NPT
 Orifice: 25 mm, 1"
 Cv: 12, SCFM: 336
 Pressure Range: 10-150 PSI



TB12JB-XXX-X
 Port Size: 1 1/4" NPT
 Orifice: 38 mm, 1 1/2"
 Cv: 22, SCFM: 615
 Pressure Range: 10-150 PSI

TB14JB-XXX-X
 Port size: 1 1/2" NPT
 Orifice: 38 mm, 1 1/2"
 Cv: 22, SCFM: 615
 Pressure Range: 10-150 PSI

Ordering Information

Replace XXX-X with voltage needed
 000-N = No Coil
 012-D = 12 VDC
 024-D = 24 VDC
 024-A = 24 VAC
 120-A = 120 VAC

Technical Data

Temperature Range: 0 - 180 F
 Duty Cycle: 100 %
 Power consumption: 22 VA
 Response Time: 50 ms

NOTE: All valves are shown with a CSN-30 connector.
 Connector is to be ordered separately.
 See page 79 for ordering information.

2-Way Stainless Steel Solenoid/Pilot Acting Valves

- Valves are internally piloted, normally closed and excellent for high flow applications.
- # 304 stainless steel body, stainless steel stem and viton diaphragm provide excellent durability.
- Suitable for use with beverage dispensing, water, air, lightweight oil, and liquid gas and most chemical liquids.
- Available in 12 VDC, 24 VDC, AND 120 VAC coils.



TS03EV-XXX-X

Port Size: 3/8" NPT
Orifice: 13 mm, 33/64"
Cv: 4.5, SCFM: 126
Pressure Range: 10-150 PSI



TS06HV-XXX-X

Port Size: 3/4" NPT
Orifice: 25 mm, 1"
Cv: 12, SCFM: 336
Pressure Range: 10-150 PSI

TS04EV-XXX-X

Port size: 1/2" NPT
Orifice: 13 mm, 33/64"
Cv: 4.5, SCFM: 126
Pressure Range: 10-150 PSI

TS08HV-XXX-X

Port size: 1" NPT
Orifice: 25 mm, 1"
Cv: 12, SCFM: 336
Pressure Range: 10-150 PSI



TS12JV-XXX-X

Port Size: 1 1/4" NPT
Orifice: 38 mm, 1 1/2"
Cv: 22, SCFM: 615
Pressure Range: 10-150 PSI



TS14JV-XXX-X

Port Size: 1 1/2" NPT
Orifice: 38 mm, 1 1/2"
Cv: 30, SCFM: 839
Pressure Range: 10-150 PSI



TS20KV-XXX-X

Port Size: 2" NPT
Orifice: 50 mm, 2"
Cv: 48, SCFM: 1343
Pressure Range: 10-150 PSI

Ordering Information

Replace XXX-X with voltage needed
000-N = No Coil
012-D = 12 VDC
024-D = 24 VDC
024-A = 24 VAC
120-A = 120 VAC

Technical Data

Temperature Range: 0 - 180 F
Duty Cycle: 100 %
Power consumption: 22 VA
Response Time: 50 ms

NOTE: All valves are shown with a CSN-30 connector. Connector is to be ordered separately. See page 79 for ordering information.

2-Way Direct Acting

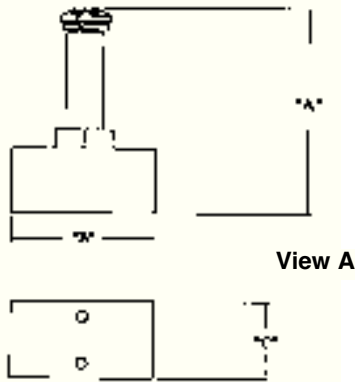

View A

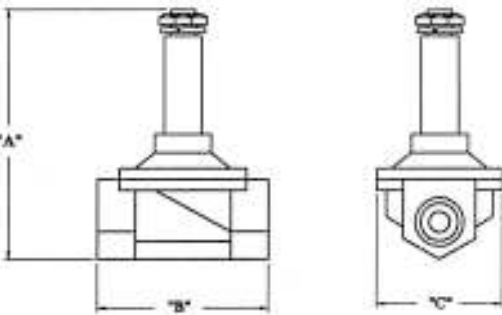

View B

P/N	VIEW	"A"	"B"	"C"	PORT SIZE	REPAIR KIT
TB011B-XXX-X	A	2.835	.866	.866	1/8	-
TB022B-XXX-X	A	2.972	1.378	1.000	1/4	-
TB034B-XXX-X	A	3.130	2.165	1.181	3/8	-
TB035B-XXX-X	B	4.232	2.618	1.890	3/8	SK-T035B
TB045B-XXX-X	B	4.232	2.618	1.890	1/2	SK-T045B
TB066B-XXX-X	B	4.449	2.795	2.283	3/4	SK-T066B
TB087B-XXX-X	B	4.921	3.780	2.756	1	SK-T087B

2-Way Solenoid/Pilot Acting

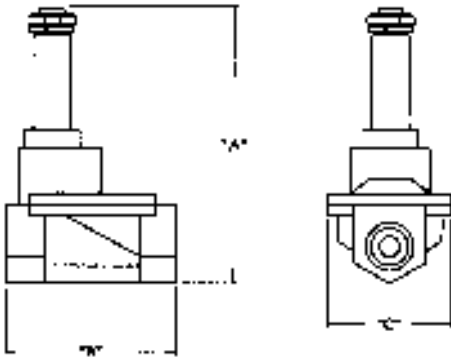

P/N	"A"	"B"	"C"	PORT SIZE	REPAIR KIT
TB03EB-XXX-X	4.193	2.618	1.890	3/8	SK-T03EB
TB04EB-XXX-X	4.193	2.618	1.890	1/2	SK-T04EB
TB06HB-XXX-X	4.961	3.780	2.756	3/4	SK-T06HB
TB08HB-XXX-X	4.961	3.780	2.756	1	SK-T08HB
TB12JB-XXX-X	5.728	5.157	3.780	1-1/4	SK-T12JB
TB14JB-XXX-X	5.728	5.157	3.780	1-1/2	SK-T14JB

2-Way Stainless Steel

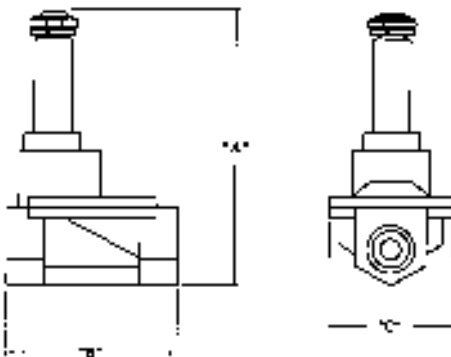

P/N	"A"	"B"	"C"	PORT SIZE	REPAIR KIT
TS03EV-XXX-X	4.193	2.618	1.890	3/8	SK-T03EV
TS04EV-XXX-X	4.193	2.618	1.890	1/2	SK-T04EV
TS06HV-XXX-X	4.980	3.937	2.756	3/4	SK-T06HV
TS08HV-XXX-X	4.980	3.937	2.756	1	SK-T08HV
TS12JV-XXX-X	5.728	5.157	3.780	1-1/4	SK-T12JV
TS14JV-XXX-X	5.728	5.157	3.780	1-1/2	SK-T14JV
TS20KV-XXX-X	6.319	6.299	4.409	2	SK-T20KV

Features

50 Series 3-Way & 4-Way Valves

- Numerous Styles and Options.
3-Way or 4-Way Configurations.
- Six Actuator Styles.

Hand Lever	Cam Stem
Palm Button	Pilot
Roller Cam	Manual Bleed
- Compact Size provides greater design flexibility.
- Perfect for low to moderate flow applications requiring manual or mechanical valve operation.

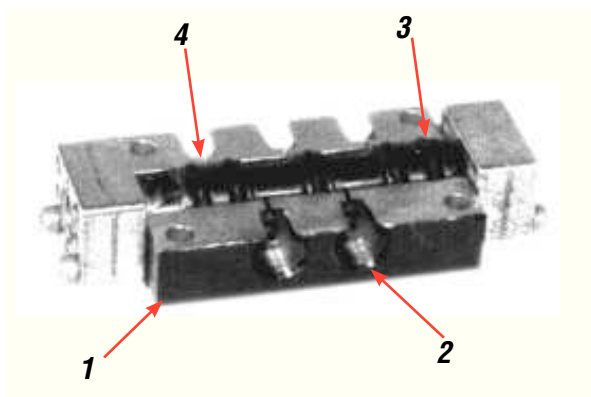

Comprehensive Valve Design

- 1. Aluminum Body**
50 Series Valves feature an extruded aluminum body for less porosity, greater durability and lighter weight.
- 2. Body Threaded Ports**
Port threads are 1/8" NPTF
- 3. Buna N Seals**
The standard spool seals are Buna N. For high temperature applications, Viton seals are available. Consult the factory for ordering information.
- 4. Sturdy Valve Spools**
Spools are steel on mechanical and manually actuated valves. Pilot and bleed actuator valves feature aluminum spools.



Hand Lever



Palm Button



Roller Cam



Cam Stem



Pilot



Manual Bleed

Ordering

3-Way and 4-Way Valves

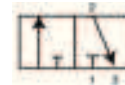

3-Way

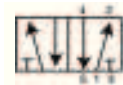

4-Way

50 X X - XX

50 Series Valves

Valve Function	
Code	Description
3	3-Way
4	4-Way

Body Style	
Code	Description
0	1/8" Side Ports
1*	1/8" Side Ports with panel mounting

*Available only with Palm Button Actuators (02, 12, 21, 22, 32, 41)

Actuator / Return	
Code	Actuator/Return
01	Hand Lever/Spring
10	Hand Lever/Manual
20	Hand Lever/Pilot
02	Palm Button/Spring
12	Palm Button/Manual
21	Palm Button/Pilot
22	Palm w/o Button/Spring
32	Palm w/o Button/Manual
41	Palm w/o Button/Pilot
05	Roller Cam/Spring
06	Cam Stem/Spring
24	Cam Stem/Pilot
07	Pilot/Spring
35	Pilot/Pilot
33	Manual Bleed/Manual Bleed

Optional Palm Buttons

Code	Description
13111	Plastic, Black
119243	Metal, Plain
119244	Metal, Red
119245	Metal, Green
MP3651-7	Plastic, Red

For 22, 32 or 41 Actuators

Performance Specifications

Pressure Range:	20-150 PSI Max. 50-150 PSI Max. (Manual Bleed Actuator)
Flow:	16 SCFM
Cv Factor:	.43 Cv
Temperature Rating:	-10° to 180°F (-23° to 82°C)
Minimum Pilot Pressure:	30 PSI (2.1 Bar) Pilot Return 60 PSI (4.2 Bar) Pilot Actuator/Spring Return Valves
Lubrication:	Valves use O-ring seals. For maximum performance and life expectancy, standard air line lubrication should be used.

Dimensional Data Dimensions given in Inches and (Millimeters)

Basic 3-Way Valve

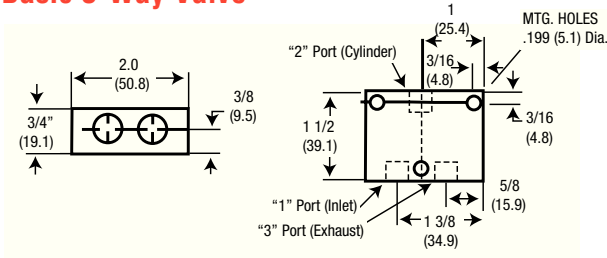

Basic 4-Way Valve

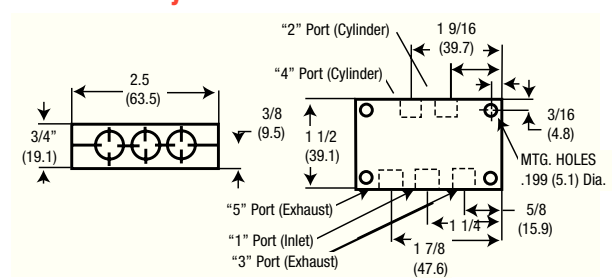

Hand Lever Valves

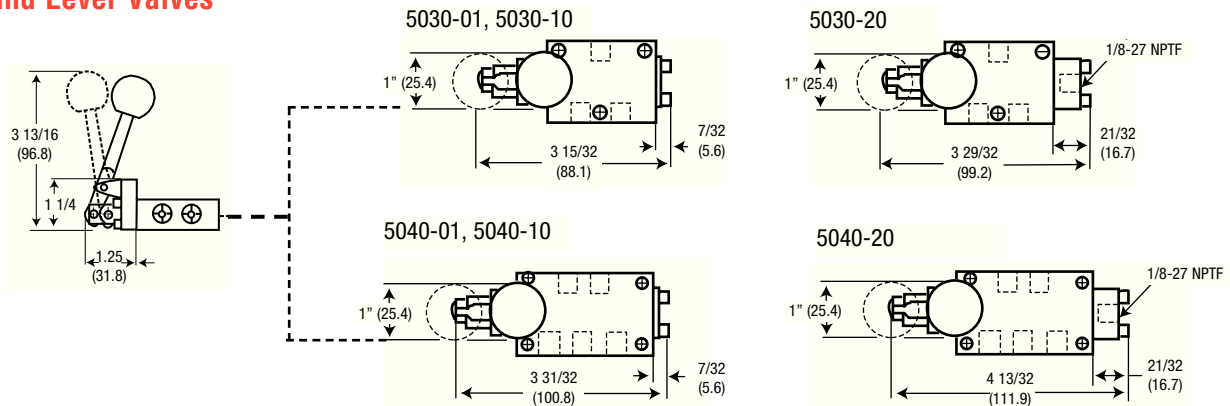

Palm Button Valves

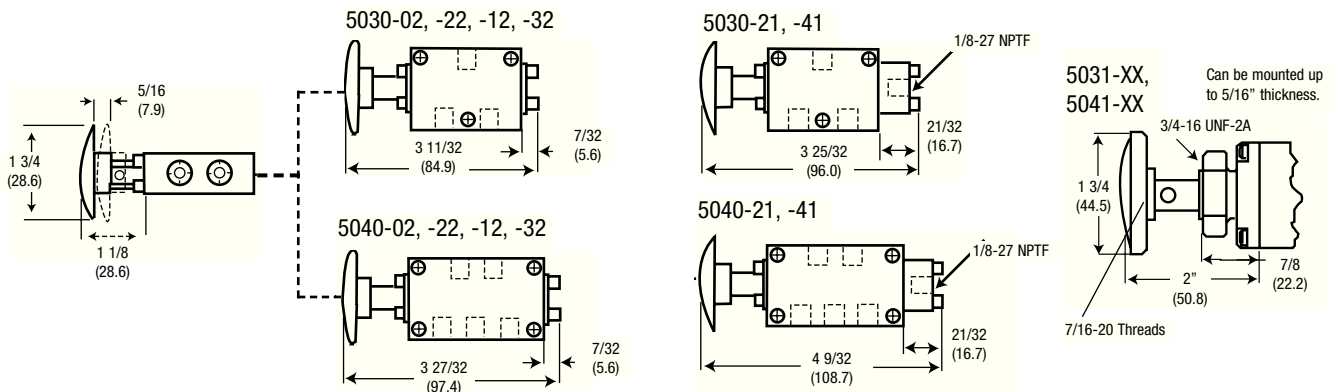

Roller Cam Valves

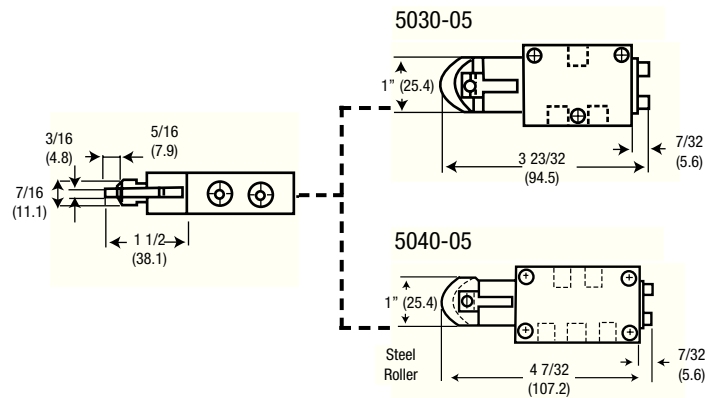

Dimensional Data Dimensions given in Inches and (Millimeters)

Cam Stem Valves

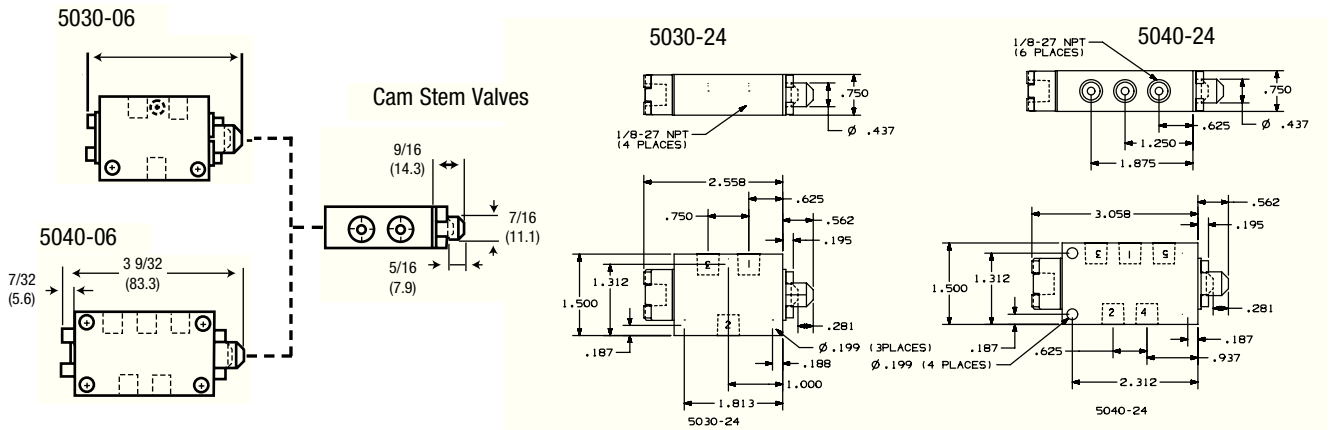

Pilot Valves

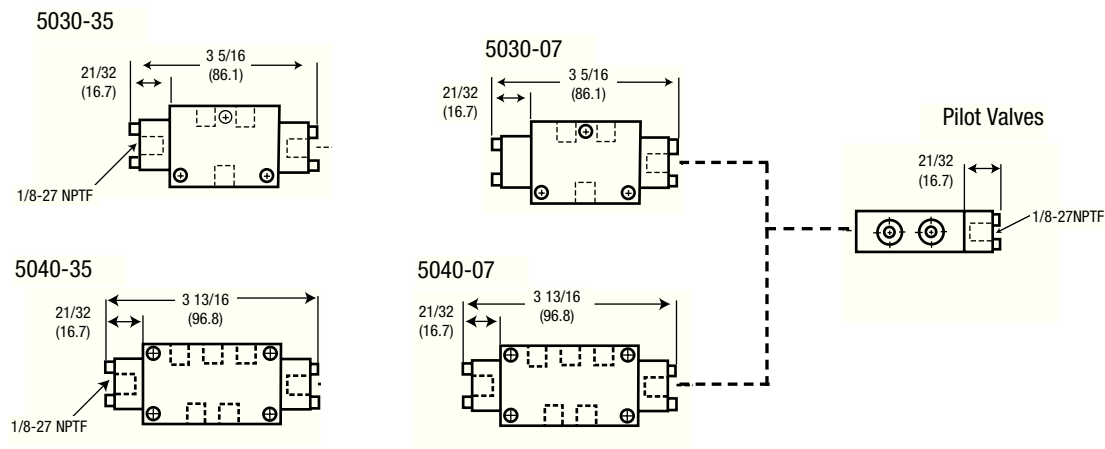

Manual Bleed Valves

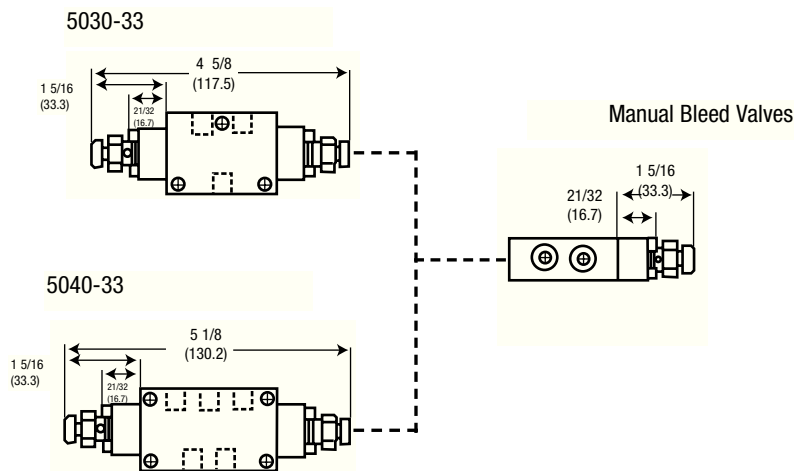

Features

3-Way and 4-Way Hand Lever Valves 1/4" and 3/8" NPT Ports

- Light weight aluminum bodies and Buna-N seals are standard
- Ideal for packaging, material handling and air motor applications.
- Hand levers available with lever parallel or perpendicular to valve body.
- Parallel lever can be manifold mounted.
See pg. 16 for manifold ordering information.
- 1/4" perpendicular hand lever valves can be panel mounted.



Perpendicular Levers

Performance Specifications

CV (Lever)	1/4" = .70, 3/8" = 1.14
Operating Medium	Non-lubricated or lubricated air
Pressure Range	20 -140 PSI
Temperature Range	15° to 122°F (-10° to 50°C)
Port Size NPT	1/4", 3/8"
Filtration	40 micron recommended



Parallel Levers

Ordering

MODEL	DESCRIPTION
Levers Perpendicular to Body	
M212LM	1/4", 4-Way, 2-Position, Lever/Manual
M212LS	1/4", 4-Way, 2-Position, Lever/Spring
M312LS	1/4", 4-Way, 3-Position, All Ports Blocked
M213LS	3/8", 4-Way, 2-Position, Lever/Spring
M213LM	3/8", 4-Way, 2-Position, Lever/Manual
M252LM	1/4", 3-Way, 2-Position, Lever/Manual
M252LS	1/4", 3-Way, 2-Position, Lever/Spring
Levers Parallel to Body	
M212LM-R	1/4", 4-Way, 2-Position, Lever/Manual
M212LS-R	1/4", 4-Way, 2-Position, Lever/Spring



Panel Mounting is standard on 1/4" NPT Perpendicular Valves

Dimensional Data

See page 21

Replacement Accessories

MODEL	DESCRIPTION
114420	Black Knob
114421	Red Knob
114418	Boot for 1/4" Valve
114419	Boot for 3/8" Valve
114822	Lever

Dimensional Data

4-Way Hand Lever (Parallel)

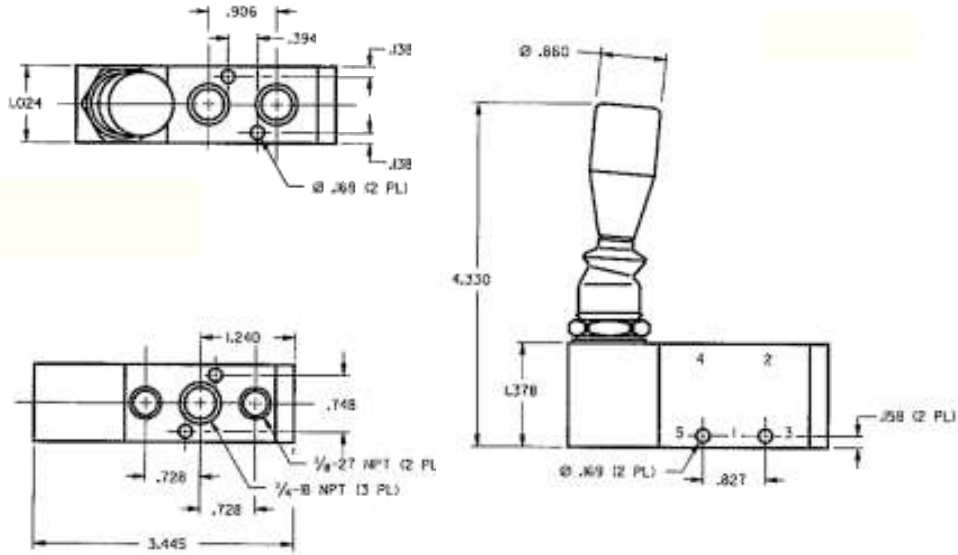

3-Way Hand Lever (Perpendicular)

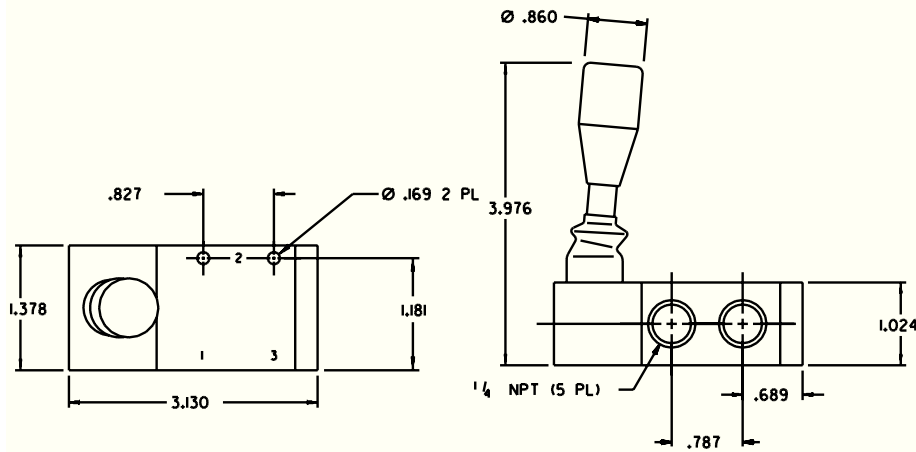

Features

4-Way, 2 & 3-Position Rotary Lever Valves 1/4" & 3/8" 1/2" NPT Ports

- Light weight aluminum bodies and Buna-N seals are standard
- Ideal for packaging, material handling and air motor applications.
- Rotary lever valve is a 3-position, all ports blocked, manual return.
- Panel mount nut is supplies as standard.



M512LR
M513LR
M514LR

Performance Specifications

SCFM	1/4" = 40, 3/8" = 65, 1/2" = 85
CV (Rotary Lever)	1/4" = 1.25, 3/8" = 2.0, 1/2" = 2.4
Operating Medium	Non-lubricated or lubricated air
Pressure Range	20 -140 PSI
Temperature Range	15° to 122°F (-10° to 50°C)
Port Size NPT	1/4", 3/8", 1/2"
Filtration	40 micron recommended

Ordering

Model	Description
Rotary Hand Lever	
M112LR	1/4", 4-Way, 2-Position, Manual
M113LR	3/8", 4-Way, 2-Position, Manual
M114LR	1/2", 4-Way, 2-Position, Manual
M512LR	1/4", 4-Way, 3-Position, Manual
M513LR	3/8", 4-Way, 3-Position, Manual
M514LR	1/2", 4-Way, 3-Position, Manual

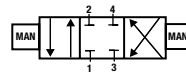

4-Way 3-Position (Rotary Hand)

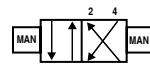

4-Way 2-Position (Rotary Hand)

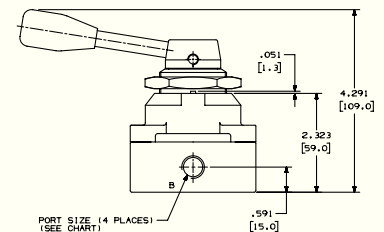
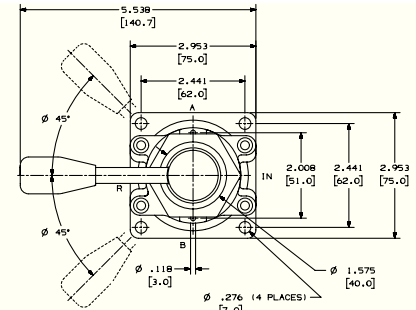

Features

3-Way & 4-Way Foot Pedal Valves

- Rugged aluminum alloy housing and pedal provide excellent durability and are light weight.
- Valves are available with a mechanical detent or as spring return.
- Mechanical detent 3-way and 4-way valves have a guard for applications where accidental actuation may result in injury or damage.
- Guard is safety yellow composite construction.



M252FS
Foot Pedal Valve

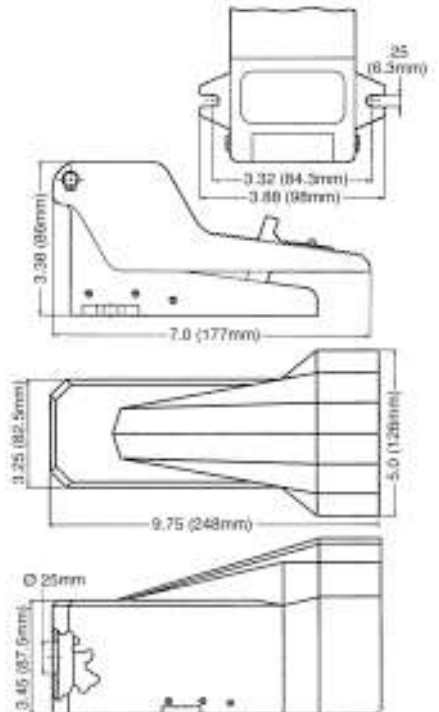

Performance Specifications

Port Size:	1/4" NPT
Pressure Range:	30-150 PSI
Temperature Range:	32° to 160°F (0° to 71°C)
Media	Compressed Air

Ordering

Model	Description
M252FS	3-Way, Spring Return, No Guard
M212FS	4-Way, Spring Return, No Guard
M252TM	3-Way, Mechanical Detent, With Guard
M212TM	4-Way, Mechanical Detent, With Guard
114417	Guard only
M252TS	3-Way, Spring Return, With Guard
M212TS	4-Way, Spring Return, With Guard
114645	Clip (Foot Pedal)



Foot Pedal Valve
Show with Guard



- Rugged aluminum body is lightweight and durable.
- Valves are available with roller cam, cam stem, push button, or selector, with spring return.
- Ideal for sensing the position and controlling moving devices such as cylinders, slides and gates.
- 1/4" 3-way valves can be plumbed to perform as normally passing, normally non-passing, or selector. 1/8" 3-way can only be used as normally non-passing.
- Stock the basic cam stem valve and a selection of actuators to meet most application needs.

3-Way, 1/8"

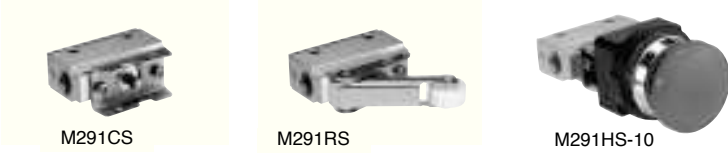

Technical Data

Port size:	1/8" NPT
Pressure Range:	0-150 PSI
Temperature: Range	32-160 F (0-71 C)
Media:	Compressed Air
Flow:	C _v =.2, 8 scfm

3-Way, 1/4"



Technical Data

Port size:	1/4" NPT
Pressure Range:	0-150 PSI
Temperature: Range	32-160 F (0-71 C)
Media:	Compressed Air
Flow:	C _v =.7, 26 scfm

4-Way, 1/4"

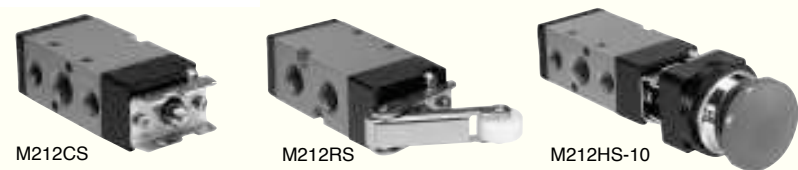

Technical Data

Port size:	1/4" NPT
Pressure Range:	0-150 PSI
Temperature: Range	32-160 F (0-71 C)
Media:	Compressed Air
Flow:	C _v =.7, 26 scfm



M291HS-15



M291HS-11



M291HS-13



M291LS-10



M291LS-11



M291LS-10-2

Ordering Information | 3-Way, 1/8" NPT

Complete Models Basic Valves

M291HS-17	3-Way, Standard Palm Button, Spring Return (Green)
M291HS-10	3-Way, Standard Palm Button, Spring Return (Red)
M291HS-15	3-Way, Palm Button w/Detent, Spring Return
M291HS-11	3-Way, Palm without Guard, Spring Return
M291HS-13	3-Way, Palm w/Guard, Spring Return
M291LS-10	3-Way, Standard Selector, Manual
M291LS-11	3-Way, Long Knob Selector, Manual
M291RS	3-Way, Roller Lever, Spring Return
M291CS	Basic Valve, 3-Way, Cam Stem, Spring Return
M291LS-10-2	3-Way, Two Valve Kit (Both valves actuate at same time)

Actuators Only

114597-10	Standard Palm Button Actuator (Red)
114597-11	Palm Button without Guard (Red)
114597-13	Palm Button w/Guard (Red)
114597-15	Palm Button w/Detent (e-stop) (Red)
114598-10	Standard Knob (Black)
114598-11	Long Knob (Black)
114599	Roller Lever
114597-17	Standard Palm Button Actuator (Green)



M252HS-15



M252HS-11



M252HS-13



M252LS-10



M252LS-11

Ordering Information | 3-way, 1/4" NPT

Complete Models

M252HS-17	3-Way, Standard Palm Button, Spring Return (Green)
M252HS-10	3-Way, Standard Palm Button, Spring Return (Red)
M252HS-15	3-Way, Palm Button w/Detent
M252HS-11	3-Way, Palm without Guard, Spring Return
M252HS-13	3-Way, Palm w/Guard, Spring Return
M252LS-10	3-Way, Standard Selector, Manual
M252LS-11	3-Way, Long Knob Selector, Manual
M252RS	3-Way, Roller Lever, Spring Return
M252CS	Basic Valve, 3-Way, Cam Stem, Spring Return

Actuators Only

114597-10	Standard Palm Button Actuator (Red)
114597-11	Palm Button without Guard (Red)
114597-13	Palm Button w/Guard (Red)
114597-15	Palm Button w/Detent (e-stop) (Red)
114598-10	Standard Knob (Black)
114598-11	Long Knob (Black)
114599	Roller Lever
114597-17	Standard Palm Button Actuator (Green)



M212HS-15



M212HS-11



M212HS-13



M212LS-10



M212LS-11

Ordering Information | 4-Way, 1/4" NPT

Complete Models

M212HS-17	4-Way, Standard Palm Button, Spring Return (Green)
M212HS-10	4-Way, Standard Palm Button, Spring Return (Red)
M212HS-15	4-Way, Palm Button w/Detent, Spring Return
M212HS-11	4-Way, Palm without Guard, Spring Return
M212HS-13	4-Way, Palm w/Guard, Spring Return
M212LS-10	4-Way, Standard Selector, Manual
M212LS-11	4-Way, Long Knob Selector, Manual
M212RS	4-Way, Roller Lever, Spring Return
M212CS	Basic Valve, 4-Way, Cam Stem, Spring Return

Actuators Only

114597-10	Standard Palm Button Actuator (Red)
114597-11	Palm Button without Guard (Red)
114597-13	Palm Button w/Guard (Red)
114597-15	Palm Button w/Detent (e-stop) (Red)
114598-10	Standard Knob (Black)
114598-11	Long Knob (Black)
114599	Roller Lever
114597-17	Standard Palm Button Actuator (Green)

Features

3-Way & 4-Way Valves

Several Styles and Options

3-Way or 4-Way Configurations. 2-and 3-position configurations.

Numerous Actuator Styles

<u>Manual</u>	<u>Mechanical</u>	<u>Electric</u>	<u>Pneumatic</u>
Hand Lever	Cam Stem	Single Solenoid	Pilot
Palm Button	Roller Cam	Double Solenoid	Bleed
Pedal			
Treadle			

Many Performance Features

Buna-N spool seals are standard. Viton seals are available for high temperature applications. Consult the factory for ordering information.

The E Series Valve has a low profile. An extruded aluminum body provides excellent durability and lighter weight.

An External Solenoid Supply Port allows service in low pressure applications. This requires a #116153 plug Kit. See Page 56 for operation and ordering information.

Solenoid Override

Manual locking override is standard on solenoid models. Turn override to operate.

Solenoid override is a convenient means to set-up and trouble shoot circuits. Air pressure at the solenoid exhaust will also override the solenoid.

Coils

Coils are UL and CSA Listed (Files: UL #MH13513; CSA #LR51090).

Performance Specifications

Pressure Ranges:	Min. Pilot Press	
	PSI (Bar)	PSI (Bar)
Manual Actuators		
Manual, Spring, and Spring Centered Returns:	20-150 (1.4-10.2)	30 (2)
Mechanical Actuators		
Manual, Spring, and Spring Centered Returns:	20-150 (1.4-10.2)	30 (2)
Electric Actuators		
Spring Return	30-150 (2-10.2)	
Spring Centered Return	35-150 (2.4-10.2)	
Solenoid Return	20-150 (1.4-10.2)	
Pneumatic Actuators		
Pilot/Spring Return	20-150 (1.4-10.2)	30 (2)
Pilot/Spring Centered	20-150 (1.4-10.2)	35 (2.4)
Pilot/Pilot Return	20-150 (1.4-10.2)	15 (1)
Bleed/Spring Return	20-150 (1.4-10.2)	
Bleed/Bleed	20-150 (1.4-10.2)	

Flow: 26 SCFM

Cv Factor: .70 Cv

Temperature Ratings: -10° to 180° F (-23° to 82° C)

Weight: Solenoid Valves 1.8 to 3.4 oz. (.82 to 1.5 g)
Non-Solenoid Valves .7 to 1.3 oz. (.32 to .6 g)

Lubrication: Valves use O-ring seals. For maximum performance and life expectancy, standard air line lubrication should be used.



Hand Lever



Palm Button



Pedal



Treadle



Cam Stem



Roller Cam



Solenoids



Pilot



Bleed

Ordering

E X X 2 XX - XXX - X

E Series Valves

Valve Type

Code	Description
1	2 Position Detent
2	2 Position
3	3 Position Spring Centered
5	3 Position Detent (3 & 5, all ports blocked)
6	3 Position Detent (inlet ports blocked, cylinder ports open)
7	3 Position Spring Centered (6 & 7, inlet ports blocked, cylinder ports open)

Body Style

Code	Description
1	4 Way Side Ported
4*	4 Way Bottom Ported
5	3 Way Side Ported

*Solenoid and Pilot Models only.

Port Size

Code	Description
2	1/4" NPT

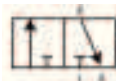

3-Way



4-Way, 2-Position

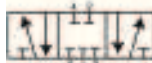

4-Way, 3-Position
all ports blocked



4-Way, 3-Position inlet ports
blocked, cylinder ports open

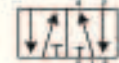

4-Way, 2-Position Bleed
Valve

Current Type

Code Description

A	AC
D	DC
N	No Coil

Required only on Solenoid Valves.

If coil option A or D is selected, a coil connector must be ordered. See Pg. 79 for coil & connector information.

Coil Voltage

Code	Description	Code	Description
000	No Coil	024	24V (AC or DC)
005	5V (AC or DC)	120	120V (AC or DC)
012	12V (AC or DC)	240	240V AC

Required only when ordering Solenoid Valves.

Actuator / Return

Code	Actuator/Return
BD	Bleed Double
BS	Bleed/Spring
CS	Cam Stem/Spring
US	Cam Stem/Spring, 1/4" Spool travel, 3-way valve only.
RS	Roller Cam/Spring
HM	Palm/Manual
HP	Palm/Pilot
HS	Palm/Spring
WM	Palm w/o Button/Manual
WP	Palm w/o Button/Pilot
WS	Palm w/o Button/Spring

Actuator / Return

Code	Actuator/Return
LM	Hand Lever/Manual
LP	Hand Lever/Pilot
LS	Hand Lever/Spring
PD	Pilot/Double
PS	Pilot/Spring
SD	Double Solenoid
SN	Solenoid/Spring-N.O.
SS	Solenoid/Spring
FS	Pedal/Spring
TM	Treadle/Manual
TS	Treadle/Spring

Numbering ends here if a Non-Solenoid Valve is being selected.

Accessories

Palm Buttons

For use with **WM**, **WP** or **WS** Actuators.

13111	Plastic, Black
119243	Metal, Plain
119244	Metal, Red
119245	Metal, Green
MP3651-7	Plastic, Red



20965-1

Foot Pedal Guards

Recommended for applications where accidental actuation may result in damage or injury. Model 20965-1 is designed to comply with ANSI No. B11.1-1971 specifications and OSHA regulations.

20965-1	Pedal Guard with Flapper
20965-2	Pedal Guard without Flapper

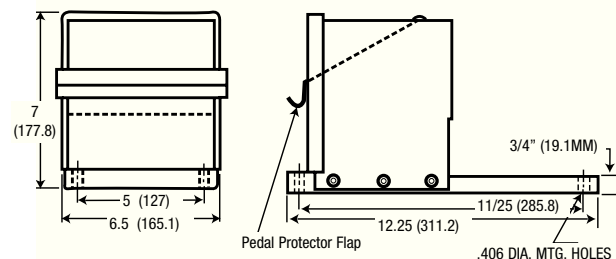

NOTE: Not for use with treadle actuator

Dimensional Data Dimensions given in Inches and (Millimeters)

Palm Button Valves

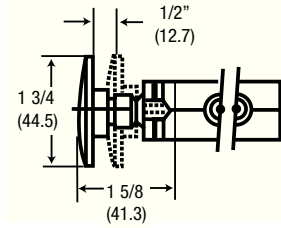

Palm Button Valves may be panel mounted. 1/8" Max. panel thickness utilizing two 10-24 UNC tapped holes in end cap
Not Available on detent models:
 E152HM or -WM
 E112HM or -WM

3 Way Valves

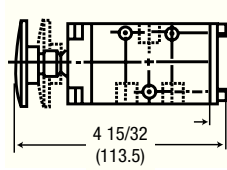

E252HM or -WM
 E152HM or -WM

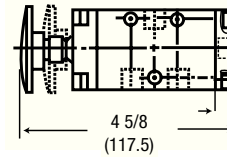

E252HP or -WP

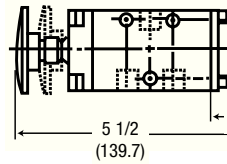

E252HS or -WS

4 Way Valves

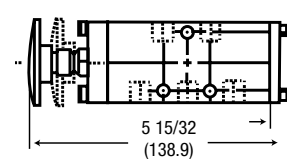

E212HM or -WM
 E112HM or -WM

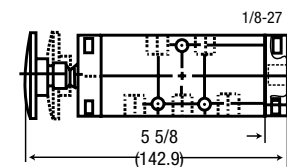

E112HP or -WP
 E212HP or -WP

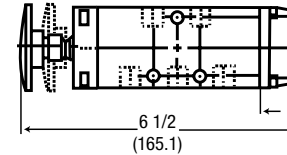

E212HS or -WS

Roller Cam Valves

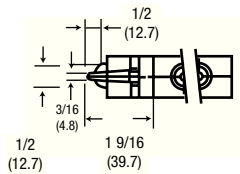

3 Way Valves

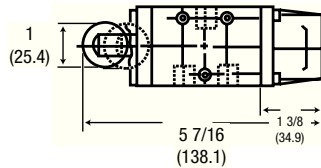

E252RS

4 Way Valves

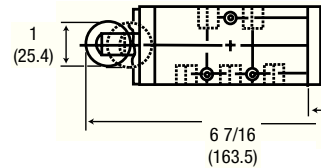

E212RS

Cam Stem Valves

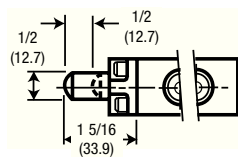

3 Way Valves

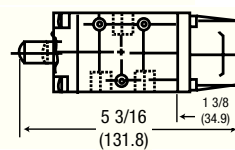

E252CS

4 Way Valves

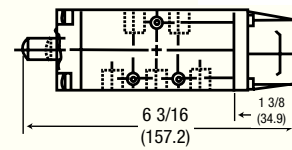

E212CS

Pilot Valves

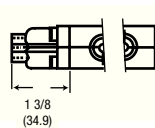

3 Way Valves

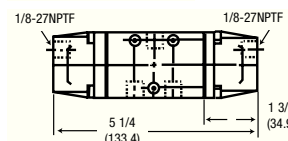

E252PS
 E252PD

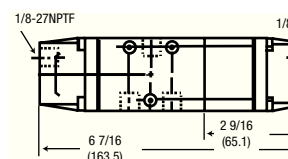

E152PD

4 Way Valves

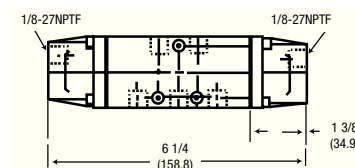

E212PS
 E212PD

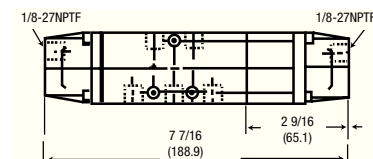

E112PD
 E312PD
 E712PD

Dimensional Data Dimensions given in Inches and (Millimeters)

Treadle Valves

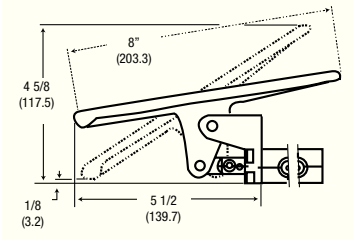

3 Way Valves

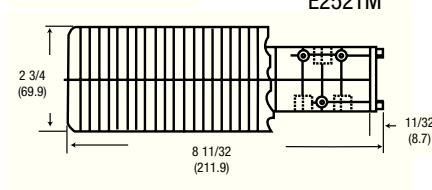

4 Way Valves

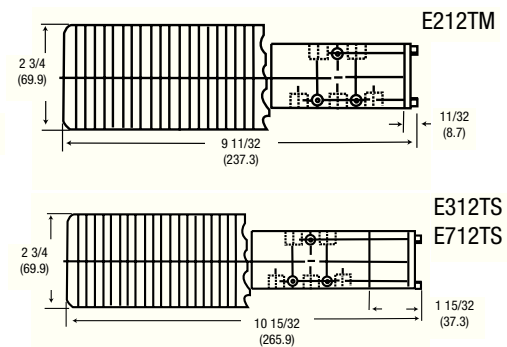

Bleed Valves

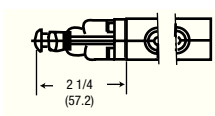

3 Way Valves

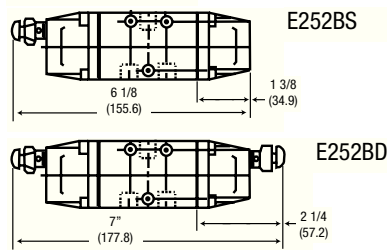

4 Way Valves

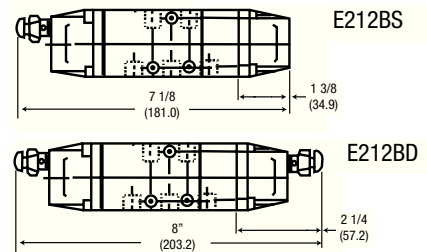

Solenoid Valves

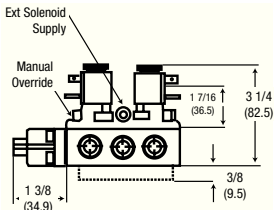
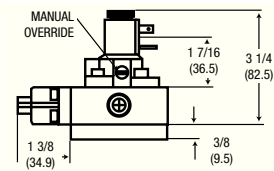

3 Way Valves

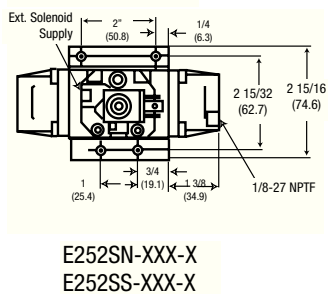

4 Way Valves

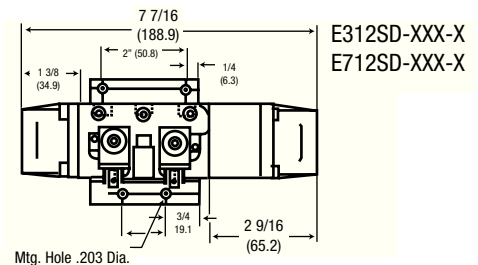
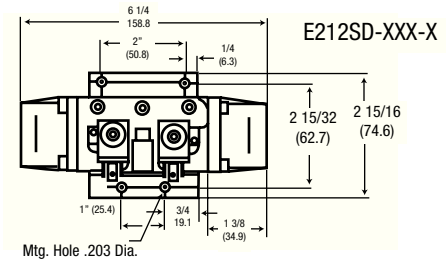
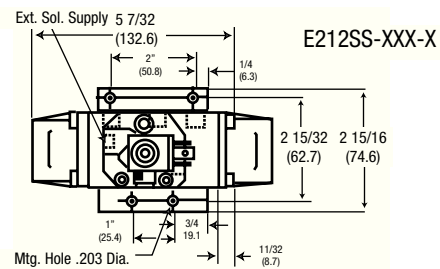

Accessories

116153 Plug Kit

Kit needed for low pressure applications requiring an external Solenoid Supply Pressure. To use, remove and discard the standard pipe plug in the solenoid base. Thread the Plug/O-ring assembly into the threaded port. This blocks the internal supply connection. Finish by connecting an external air supply to the 1/8 NPTF port.

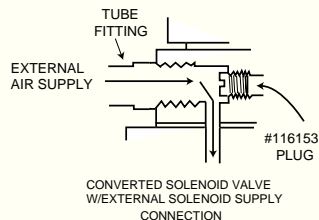
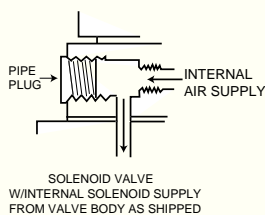

Features

Styles and Options.

5-Port, 4-Way, 2 and 3-position directional control valves.

Seven Actuator Styles.

Manual	Electric	Pneumatic
Hand Lever	Single Solenoid	Pilot
Pedal	Double Solenoid	Bleed
Treadle		
Palm Button		

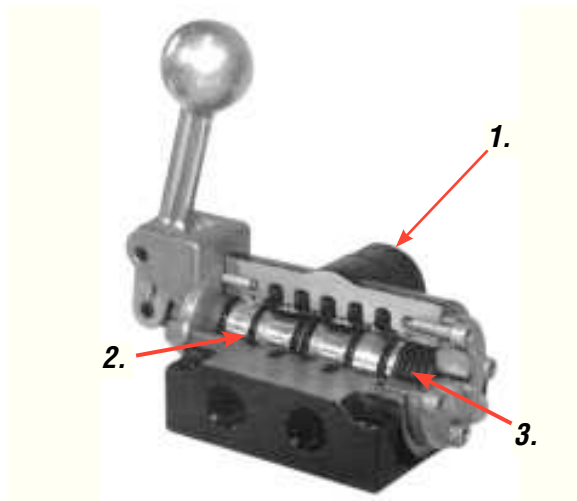

Comprehensive Valve Design

1. Aluminum Body

Sand cast aluminum body provides a rugged, reliable valve.

2. Buna N Seals

Standard seals are Buna N, for extended valve life. Viton seals are available for high temperature applications. Consult factory for ordering information.

3. Sturdy Spools

K-Series valves have an aluminum spool. This slides in a hard anodized Teflon non-stick aluminum sleeve (3/8" or 1/2" models) The sleeves are brass on 3/4" or 1" models.

4. Standard Solenoid Override Feature

3/8" and 1/2" models only.

5. External Solenoid

External Solenoid supply port enables valve operation for vacuum service or low pressure operations. For proper supply connection, consult factory. (Remove end cap and rotate gasket 90° for remote solenoid supply.)



Hand Lever



Pedal



Treadle



Solenoids



Pilot



Bleed

Ordering

K X X X XX - XXX - X

K Series Valves

Valve Type

Code	Description
2	2 Position
3	3 Position Spring Centered
5	3 Position Detent (3 & 5 all ports blocked in neutral)
6	3 Position Detent (inlet ports blocked, cylinder ports open in neutral)
7	3 Position Spring Centered (6 & 7 inlet ports blocked, cylinder ports open in neutral)

Body Style

Code	Description
1	4 Way Side Ported

Current Type

Code	Description
A	AC
D	DC
N	No Coil

Only on Solenoid Valves.

Coil Voltage

Code	Description
000	No Coil
005	5V (DC only)
012	12V (AC or DC)
024	24V (AC or DC)
120	120V (AC or DC)
240	240V (AC only)

Required only with Solenoid Valves

Actuator / Return

Code	Actuator/Return
BD	Bleed/Bleed
BS	Bleed/Spring
*FP	Pedal/Pilot
*FS	Pedal/Spring
**HS	Palm/Spring
*LM	Hand Lever/Manual
*LS	Hand Lever/Spring
PD	Pilot/Pilot
PS	Pilot/Spring
SD	Solenoid/Solenoid
SS	Solenoid/Spring
*TM	Treadle/Manual

*FP, FS, LM, LS & TS available in 3/8" and 1/2" port sizes only.
Numbering ends here if a Non-Solenoid valve is being selected.
**HS available in 3/8" port size only.

Port Size

Code	Description
3	3/8" NPT
4	1/2" NPT
6	3/4" NPT
8	1" NPT

2-Position 3-Position, inlet ports blocked 3-Position, inlet blocked, cylinder ports open

20965-X Foot Pedal Guards, for use with Pedal Style valves.
See Pg. 53 (bottom) for details.

Performance Specifications

Pressure Ranges:

Actuator Type		PSI (Bar)	Min. Pilot Press PSI (Bar)
Manual Actuators	Manual, Spring, and Pilot	0-150 (0-10.4)	20 (1.4)
	Manual, Spring, and Pilot	0-150 (0-10.4)	20 (1.4)
Mechanical Actuators	Spring Return	50-150 (3.5-10.4)	
	Spring Centered Return	60-150 (4.1-10.4)	
	Solenoid Return	20-150 (1.4-10.4)	
Electric Actuators	Pilot/Spring Return	0-150 (0-10.4)	50 (3.5)
	Pilot/Spring Centered	0-150 (0-10.4)	60 (4.1)
	Pilot/Pilot Return	50-150 (3.5-10.4)	20 (1.4)
	Bleed/Spring Return	50-150 (3.5-10.4)	
	Bleed/Bleed	20-150 (1.4-10.4)	

Flow & Cv Factor:

Port Size	Flow	Cv Factor
3/8"	83 SCFM	2.30
1/2"	90 SCFM	2.57
3/4"	270 SCFM	7.54
1"	280 SCFM	7.80

Temperature Ratings: -10° to 180° F (-23° to 82° C)

Lubrication:

Valves use O-ring seals. For maximum performance and life expectancy, standard air line lubrication should be used.

Dimensional Data Dimensions given in Inches and (Millimeters)

Basic Valves

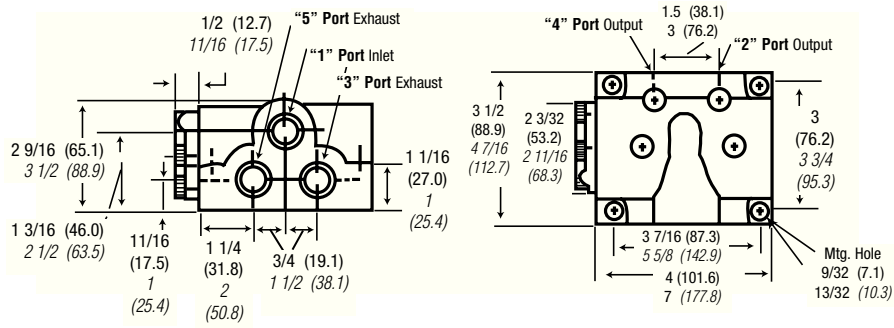

Pilot and Bleed Valves

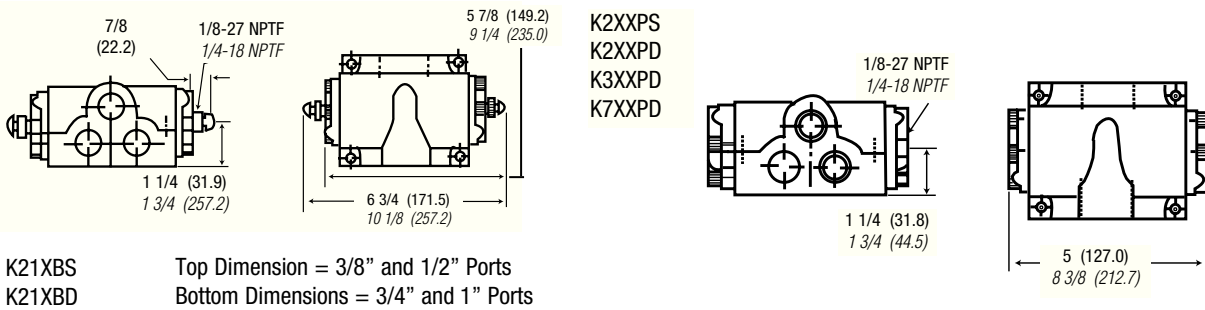

Palm Valves

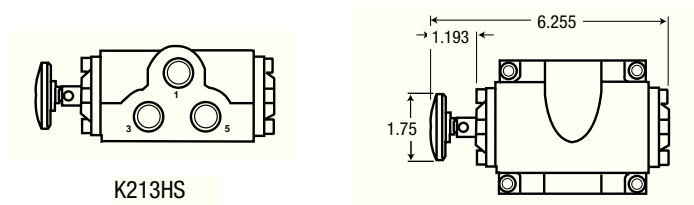

Dimensional Data Dimensions given in Inches and (Millimeters)

Hand Lever

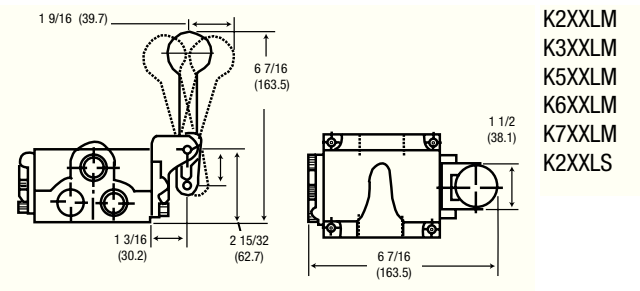

Top Dimension = 3/8" and 1/2" Ports
Bottom Dimensions = 3/4" and 1" Ports

Pedal

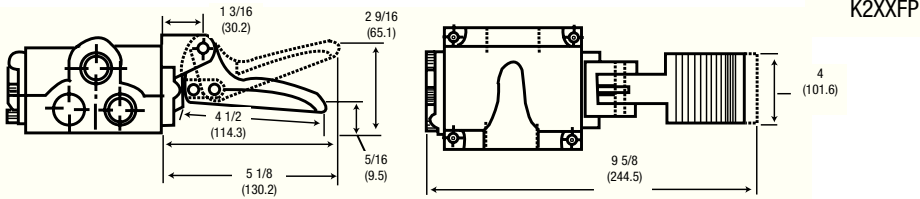

Treadle

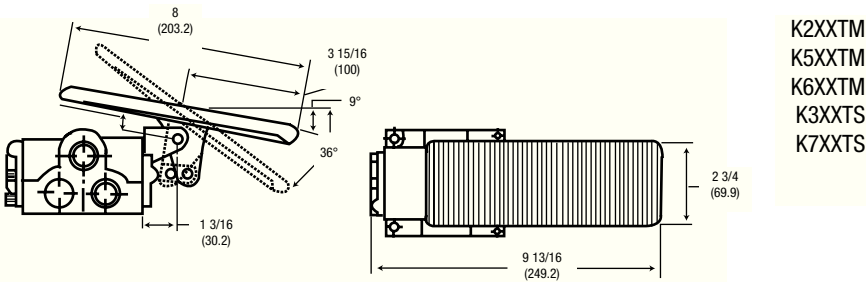

Solenoid

Double Solenoid

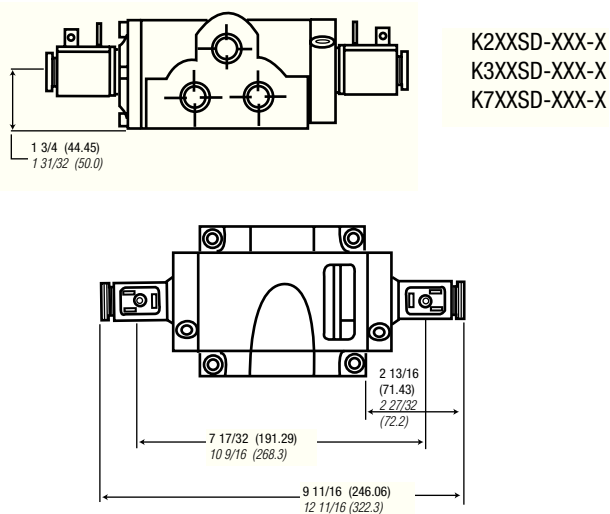

Single Solenoid

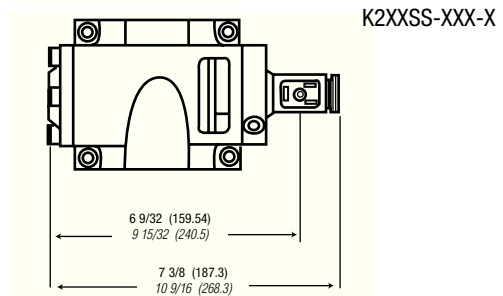

Top Dimension = 3/8" and 1/2" Ports
Bottom Dimensions = 3/4" and 1" Ports

Features

- H-Series Valves feature high-flow and fast response.
- Numerous Styles and Options.
- 3-Way and 4-Way 2-position Poppet Valves
- Several Actuator Styles.
- Override is not available with “H” Series Valves

Electric

- 3-Way Single Solenoid
- 4-Way Single Solenoid
- 4-Way Double Solenoid

Pneumatic

- 3-Way Pilot
- 4-Way Pilot
- 4-Way Pilot Bleed
- 4-Way Manual Bleed

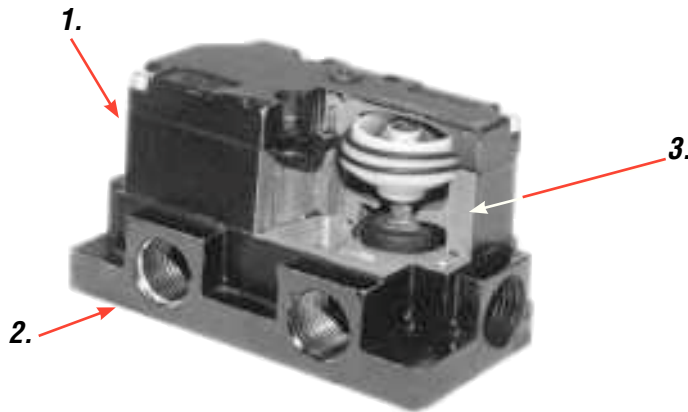

Comprehensive Valve Design

1. Durable Valve Body

Valve body is die-cast Zinc, with a zinc chromate coating for added corrosion resistance in harsh environments.

2. Superior Performance

Large, unrestricted air passages produce high flow and fast response times.

3. Superior Design

3-Way valves feature a single poppet. 4-Way valves (as shown) have two simultaneously driven poppets to provide the 4-way function.



3-Way Pilot



3-Way Solenoid



4-Way Solenoid



Manual Bleed



Pilot Bleed



4-Way Pilot

Ordering

H 2 X X XX - XXX - X

H Series Valves

Valve Type
Code Description
2 2 Position

Body Style
Code Description
1 4 Way Side Ported
5 3 Way Side Ported

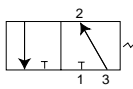

3-Way,
2-Position N.O.

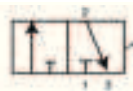

3-Way,
2-Position N.C.

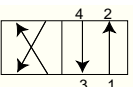

4-Way,
2-Position

Port Size
Code Description
2 1/4" NPT
3 3/8" NPT
4 1/2" NPT

Current Type
Code Description
A AC
D DC
N No Coil
Only on Solenoid Valves.

Coil Voltage
Code Description
000 No Coil
005 5V (DC only)
012 12V (AC or DC)
024 24V (AC or DC)
120 120V (AC or DC)
240 240V (AC only)
Required only with Solenoid Valves.

Actuator / Return
Code Actuator/Return
3-Way Valves
PS Pilot/Spring
SS Solenoid/Spring
4-Way Valves
BD Manual Bleed/Manual Bleed
PA Pilot/Internal Pilot
PD Pilot/Pilot
SA Solenoid/Internal Pilot
SD Solenoid/Solenoid
Numbering ends here for Non-Solenoid Valves

If coil option A or D is selected, a coil connector must be ordered. See Pg. 79 for coil & connector information.

Performance Specifications

Valve Performance Data

3-Way Valves

Actuator	Return	Pressure Range PSI (bar)	Minimum Pilot Press PSI (bar)
Pilot	Spring	30-150 (2.1-10.4)	30 (2.1)
Solenoid	Spring	30-150 (2.1-10.4)	

3-Way Valve Flow SCFM

Port Size	Side Ported	Cv Factor
1/4"	55	1.51
3/8"	81	2.27
1/2"	85	2.40

4-Way Valves

Actuator	Return	Pressure Range PSI (bar)	Minimum Pilot Press PSI (bar)
Pilot	Internal Pilot	20-150 (1.4-10.4)	20 (1.4)
Manual Bleed	Manual Bleed	20-150 (1.4-10.4)	
Pilot Bleed	Pilot Bleed	20-150 (1.4-10.4)	20 (1.4)
Solenoid	Internal Bleed or Solenoid	25-135 (1.7-9.3)	

4-Way Valve Flow SCFM

Port Size	Side Ported	Cv Factor
1/4"	50	1.40
3/8"	88	2.38
1/2"	100	2.80

Response Time @ 100 PSI

3-Way Valves

Energized	De-energized
N.O. - 23 ms	20 ms
N.C. - 22 ms	26 ms

4-Way Valves

Energized	De-energized
44 ms	27 ms

Dimensional Data Dimensions given in Inches and (Millimeters)

3-Way Basic Valves

1/4" and 3/8" Side Port

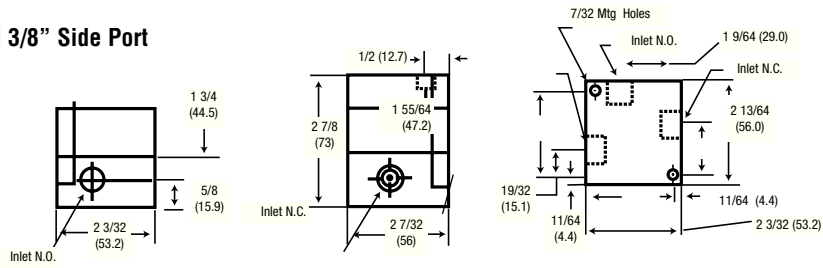

1/2" Side Port

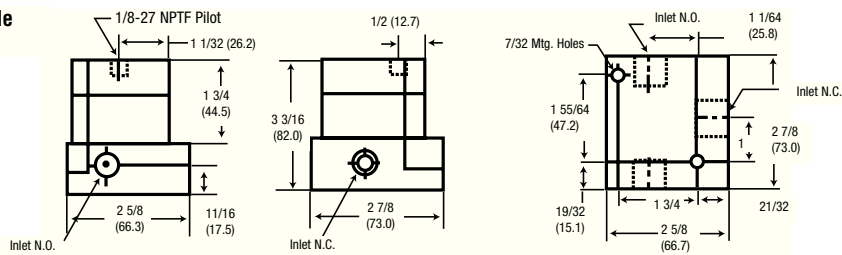

4-Way Basic Valves

1/4" and 3/8" Side Port

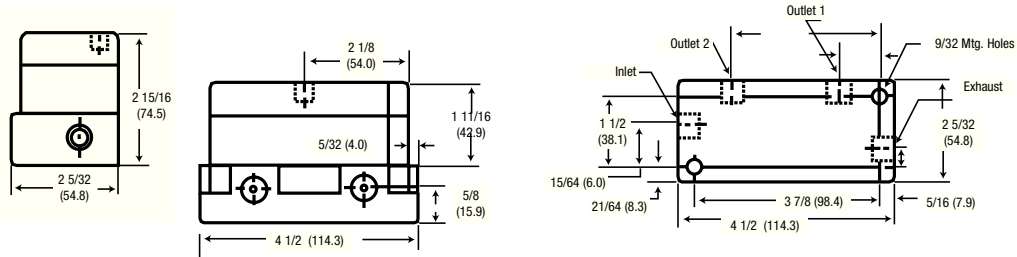

1/2" Side Port

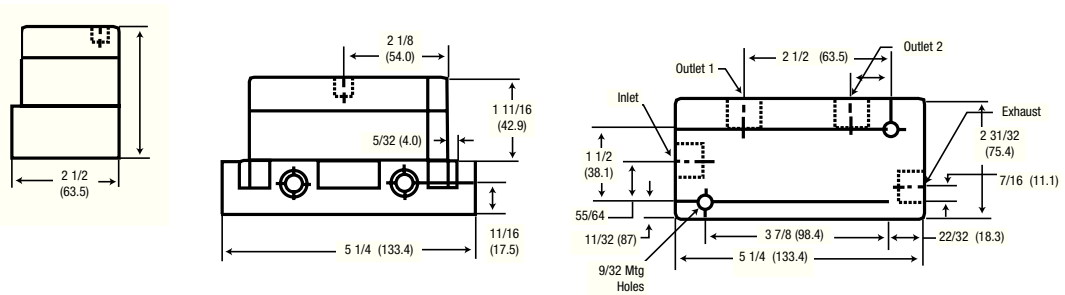

Dimensional Data Dimensions given in Inches and (Millimeters)

Pilot Valves

3-Way Pilot

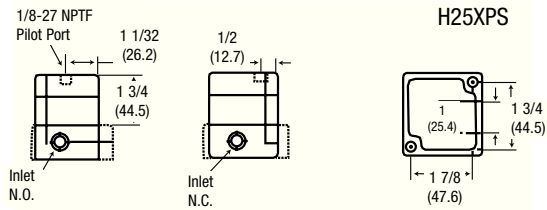

4-Way Pilot

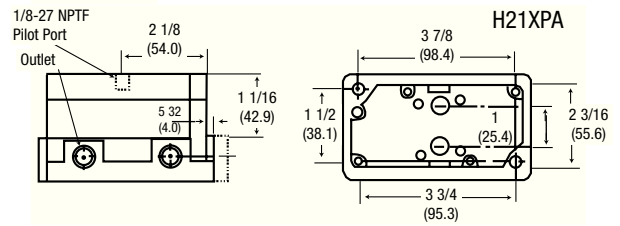

Bleed Valves

4-Way Manual Bleed

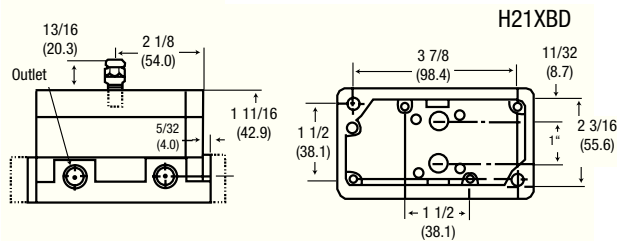

4-Way Pilot Bleed

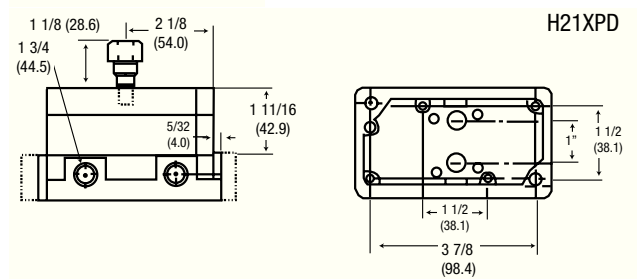

Solenoid Valves

4-Way Double Solenoid

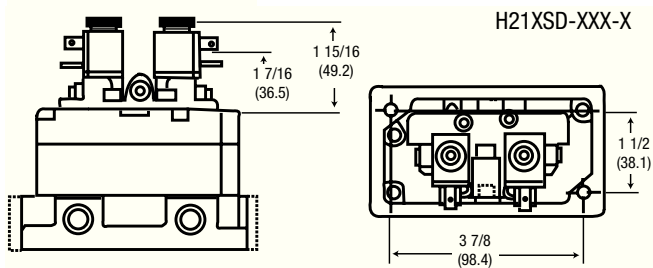

3-Way Single Solenoid

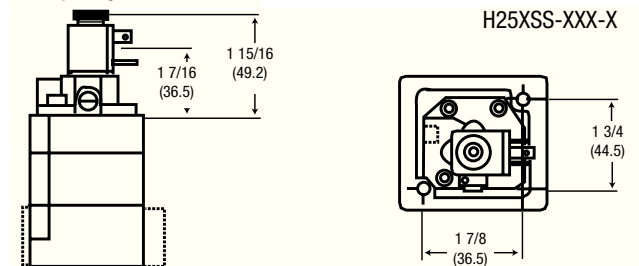

4-Way Single Solenoid

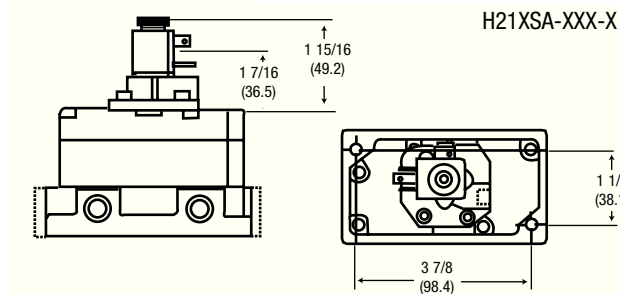

Features

- 200-Series valves can be plumbed to perform as normally passing, normally non passing, selector or any 2-way function.
- Ideal for sensing the position of moving devices such as cylinders, slides or gates.
- Mounting holes are standard 1" electrical centers
- Numerous Actuator Styles:

Mechanical

- Short Roller Lever
- Long Roller Lever
- One-Way, Short Lever
- One Way, Long Lever
- Pin Plunger

- Short Ball Roller
- Long Ball Roller
- Straight Plunger
- Roller Plunger
- Cross-Roller Plunger

Manual

- Plain Lever
- Fingertip Lever
- Centering Toggle
- Retained Toggle
- Panel Button

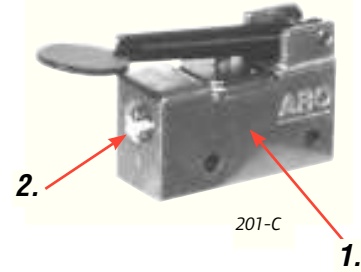

Comprehensive Valve Design

1. Durable Valve Body.

Body is die cast zinc for high wear resistance. Valve also features a stainless steel, PTFE coated spool, with Viton O-ring seals and Buna-N static seals.

2. Two Plumbing Options.

Available with 1/8" NPTF ports, or instant tube fittings for use with 5/32" (4mm) nylon tubing.

3. Numerous Actuator Styles.

Five manual, ten mechanical and one pilot actuators to choose from. Eight can be panel mounted.

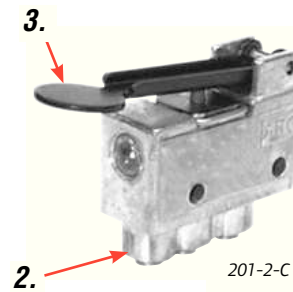

Performance Specifications

Pressure Range:

30 to 150 PSIG (2.1 to 10.4 bar)

Temperature Range:

32 to 160 F (0 to 71 C)

Actuating Force:

Actuator	Force Oz.(N)	Stroke In (mm)	Travel In (mm)
200	20 (5.56)	.195 (4.95)	.055 (1.40)
201	20 (5.56)	.289 (7.34)	.086 (2.18)
202	36 (10.0)	.086 (2.18)	.024 (0.61)
203	21 (5.84)	.160 (4.06)	.040 (1.02)
204	34 (9.45)	.089 (2.26)	.027 (.69)
205	23 (6.39)	.164 (4.17)	.043 (1.09)
209	57 (15.9)	.069 (1.57)	.015 (.38)
212	57 (15.9)	.069 (1.57)	.015 (.38)
213	57 (15.9)	.069 (1.57)	.015 (.38)
214	57 (15.9)	.062 (1.57)	.089 (2.26)
215	57 (15.9)	.062 (1.57)	.089 (2.26)
216	57 (15.9)	.062 (1.57)	.089 (2.26)
222	24 (6.67)	70°	----
223	24 (6.67)	70°	----
224	57 (15.9)	.062 (1.57)	.025 (3.18)

Flow & Cv Factor:

1/8" Ports: 7.5 SCFM Cv = .195
 5/32" (4mm) Tube Fittings: 4.0 SCFM Cv = .104

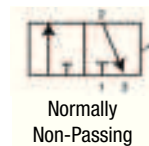
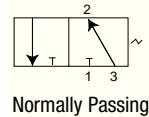

206 consist of a 212-C and a model 296 actuator



206-C Minimum Pilot Pressure PSIG (bar)

Supply Pressure	25 (1.7)	50 (3.4)	75 (5.1)	100 (6.9)	125 (8.6)	150 (10.4)
Piped IN - N.N.P.	11.5 (.8)	12.0 (.8)	12.5 (.9)	13.0 (.9)	13.5 (.9)	14.0 (1.0)
Piped IN - N.P.	14.5 (1.0)	17.0 (1.2)	19.5 (1.3)	22.0 (1.5)	24.5 (1.7)	27.0 (1.9)

Ordering

2 XX - X

200 Series		Port Type	
Actuator Type		Code Description	
Code	Description	Code	Description
00	Plain Lever	12	Short Ball Roller
01	Fingertip Lever	13	Long Ball Roller
02	Short Roller Lever	14	Straight Plunger
03	Long Roller Lever	15	Roller Plunger
04	One-Way, Short Lever	16	Cross-Roller Plunger
05	One Way, Long Lever	22	Centering Toggle
06	Pilot Actuated	23	Retained Toggle
09	Pin Plunger	24	Panel Button

Stacking Kit

Kit	# of Valves
225-2	2 Valves
225-3	3 Valves
225-4	4 Valves
225-5	5 Valves

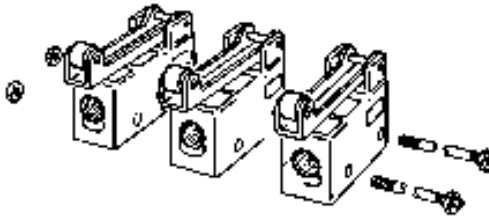

Dimensional Data

Dimensions given in Inches and (Millimeters)

Basic Valves

1/8" NPT Ports

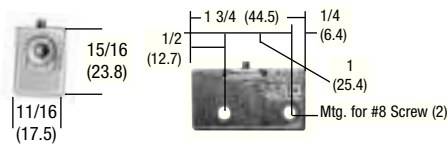

5/32" Tubing Ports

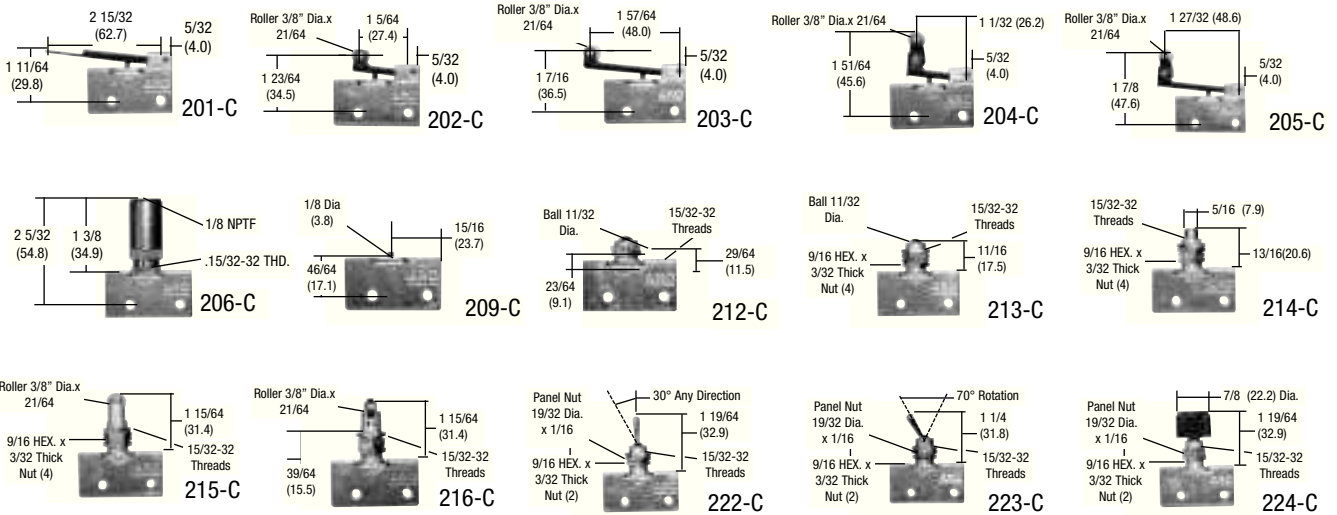
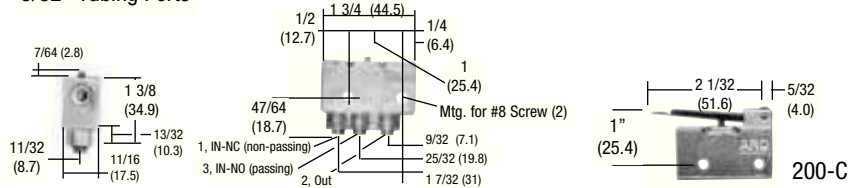

Low-Pressure Pilot Actuator Switch

- Use on 212-C ball roller limit valve.
- For use in low pilot pressure applications.
- Maximum pilot pressure is 100 pSIG (6.9 bar)
- 1/8" NPTF air inlet ports.
- Aluminum-alloy construction with low friction Buna-N cup seal.
- Order Model 20368 and 212-C Aro ball roller limit valve separately.

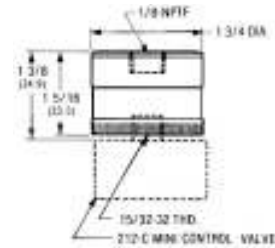

Supply Pressure	Min. Pilot Pressure PSIG (bar)					
	25 (1.7)	50 (3.5)	75 (5.2)	100 (6.9)	125 (8.6)	150 (10.4)
Piped IN-N.N.P.	5.5 (0.4)	6.0 (0.4)	6.5 (0.4)	7.0 (0.5)	7.5 (0.5)	8.0 (0.6)
Piped IN-N.P.	5.5 (0.4)	6.0 (0.4)	6.5 (0.4)	7.0 (0.5)	7.5 (0.5)	8.0 (0.6)

Features

Miniature Control Valves

- Ball Poppet valve provides fast response.
- Slotted Mounting holes for easy placement and adjustment.
- 100 Series Mini Valves are non-passing, non-lube limit valves.
- 33% glass reinforced polyester body is strong, lightweight and corrosion resistant.
- Available with 5/32" tube fittings. Both ports are on one side for ease of plumbing and maintenance.
- Seals are Buna-N, Stainless Steel Spring, Brass Plunger and Delrin Roller.

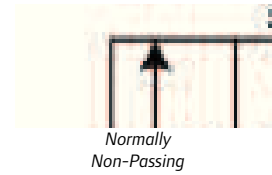

Performance Specifications

Pressure Range: 0 to 150 PSIG (0 to 10.4 bar)
Temperature Range: -10° to 180° F (-23° to 82° C)
Flow & Cv Factor: 3.4 SCFM at 100 PSIG (7 bar)
 input 85 PSI (5.8 bar) output. Cv = .09

Actuating Force:
Straight Plunger:
 52 oz. at 100 PSIG
 (14.46 N at 7 bar)
Levers:
 25 oz. at 100 PSIG
 (6.95 N at 7 bar)

Travel Operation:
Straight Plunger:
 .03125" (.8mm) to actuate
 .109375" (2.8mm) total
Levers:
 .0625" (1.6mm) to actuate
 .21875" (5.5mm) total

Ordering

Model #:	Port Size:	Actuator Type:
103-2-A	5/32" Tube	Roller Lever
105-2-A	5/32" Tube	90° Roller Lever
109-2-A	5/32" Tube	Straight Plunger

100 Series Dimensional Data Dimensions given in Inches and (Millimeters)

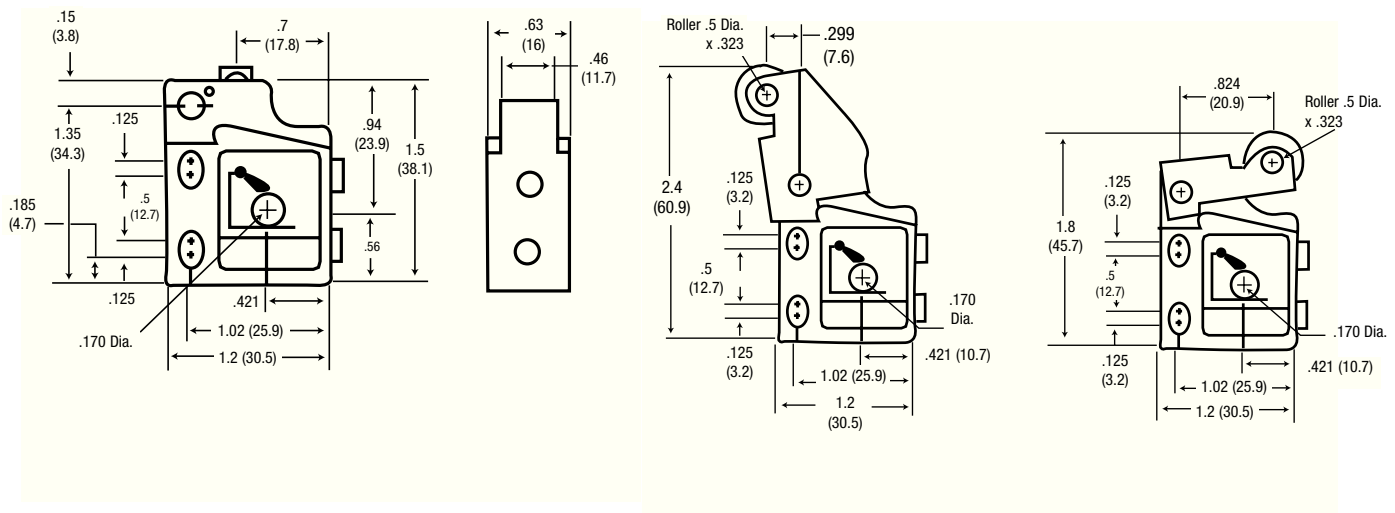

Features

MaxAir 3-Way and 4-Way, 1/8" Manual and Mechanical Valves

- Rugged aluminum alloy body is lightweight and durable.
- 3-way valves can be plumbed to perform as normally passing, normally non-passing, or selector.

Performance Specifications

Port size: 1/8" NPT Media: Compressed Air
 Pressure Range: 0-150 PSI Flow: 3-Way = 7 scfm
 Temp. Range: 32-160 F (0-71 C) 4-Way = 9 scfm

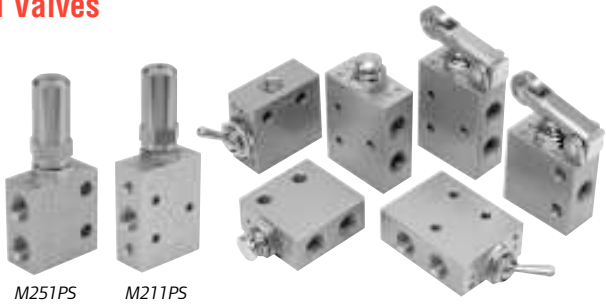

Accessory Attachments for use on M251HS & M211HS Valves

- | | | |
|----------------|--------------------------|--|
| 104484 | One-way roller lever | |
| 104485 | Ball plunger attachment | *Air pilot attachment can be ordered already assembled with valve. |
| 104486* | Air pilot attachment | M251PS 3-Way |
| 104487 | Finger button attachment | M211PS 4-Way |

M211HS 4-Way, Push Button, Spring Return**

M251HS 3-Way, Push button, Spring Return**

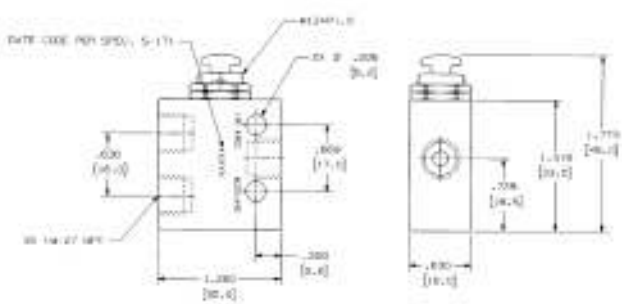
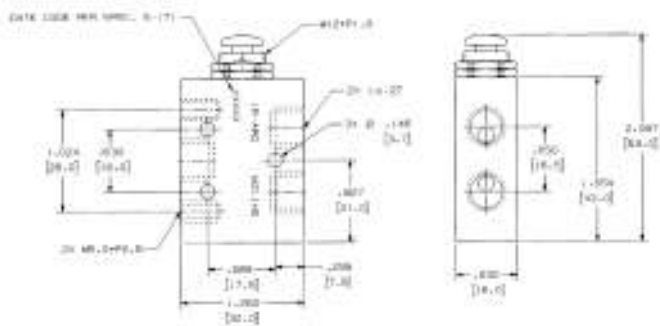

M211LS 4-Way, Toggle, Maintained

M251LS 3-Way, Toggle, Maintained

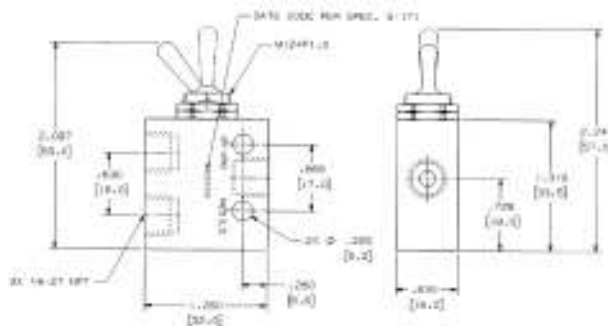
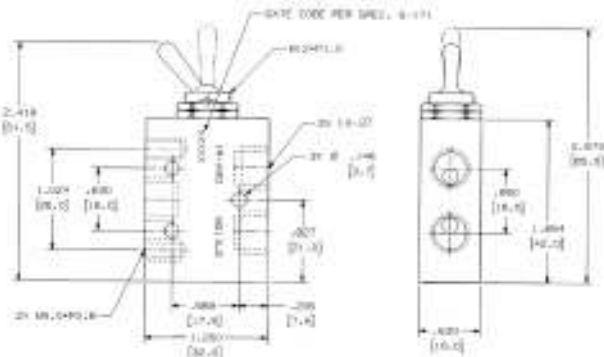

M211RS 4-Way, Roller, Spring Return

M251RS 3-Way, Roller, Spring Return

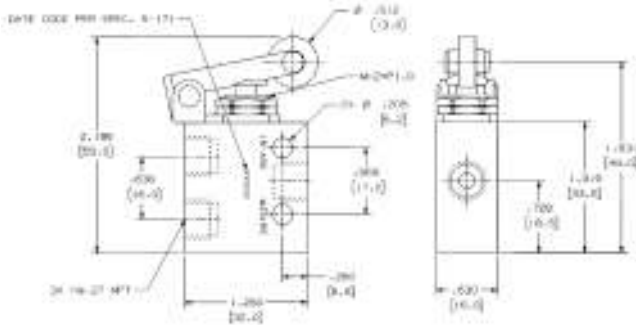
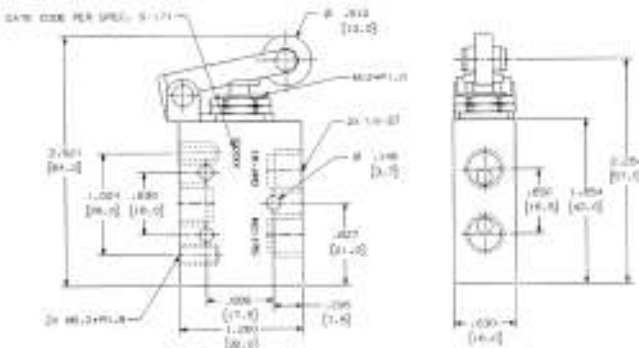

** Accessories can be mounted on push button valves for additional actuating styles

Features

3-Way Limit Valves

- Plumb 400 Series valves as normally passing, normally non-passing, selector or any 2-way valve function.
- Ports available with either 1/8" NPTF threads or 5/32" tube fittings.
- Four actuator options: Nylon Roller, Steel Roller, Rod Lever or Adjustable Roller Lever. Actuators must be ordered separately. See menu below.
- Operating head may be adjusted to any of four positions.
- Outer case protects working parts from dirt.

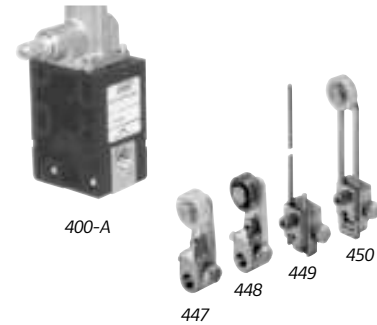

Performance Specifications

Pressure Range: 30 to 150 PSIG (2.1 to 10.4 bar)	Flow & Cv Factor: <u>1/8" Ports</u> 7.5 SCFMa Cv = .195	Actuating Force:		Actuating Torque 2.4 in. lbs.
		<u>Actuator</u>	<u>Force (lbs.)</u>	
Temperature Range: 32 to 160 F (0 to 71 C)	<u>5/32" (4mm) Tube Fittings</u> 4.0 SCFM Cv = .104	447	1.6	Normally Passing
		448	1.6	
		449	0.5	
450	0.8	Normally Non-Passing		

119605 Side Plate Cover. Used to cover body cavities.

Ordering

Valves:

<u>1/8" Ports</u>	<u>Tube Fittings</u>	<u>Valve Action</u>
400-A	400-1-A	One Way, Clockwise
401-A	401-1-A	One Way, Counterclockwise
402-A	402-1-A	Clockwise & Counterclockwise

Actuators:

<u>Code</u>	<u>Description</u>
447	Nylon Roller
448	Steel Roller
449	Rod Lever
450	Adjustable Roller

Dimensional Data

Dimensions given in Inches and (Millimeters)

400 Series

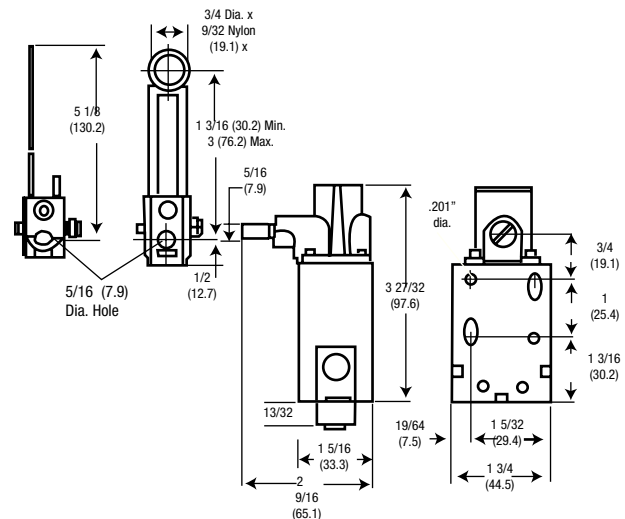
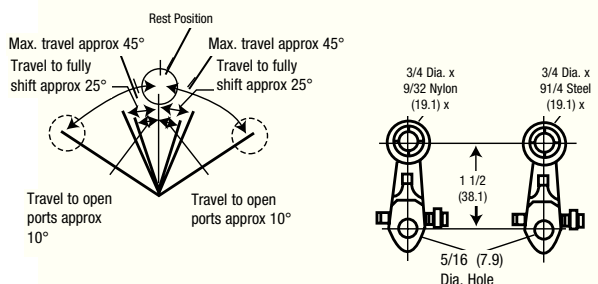

Features

Palm Button Control Valves

- Plumb each to perform as normally passing, normally non-passing, selector or any 2-way valve function.
- Ports available with either 1/8" NPTF threads or 5/32" tube fittings.
- 2 1/2" Buttons (63.5mm) are available in four colors. If needed, order 20975 guard separately.
- 460-5 and 461-5 models use buttons that are threaded on rather than pushed on, making them more tamper resistant.



460-X

461-X with 20975 Guard



461-5 with 119244 Button

Performance Specifications

Pressure Range:

30 to 150 PSIG (2.1 to 10.4 bar)

Temperature Range:

32 to 160 F (0 to 71 C)

Actuating Force:

3 lbs.

Flow & Cv Factor:

1/8" Ports

7.5 SCFM

Cv = .195

5/32" (4mm) Tube Fittings

4.0 SCFM

Cv = .104

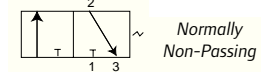
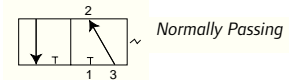

Ordering

Port Size		Button Color	
Code	Description	Code	Description
0	1/8" NPT	-1	Black
1	5/32" Tubing	-2	Red
		-3	Green
		-4	Yellow
		-5	Valve W/O Button

(Order button for 7/16"-20 TH'd separately)

Accessories

20975 Button Guard	† 13111	Plastic, Black
* 20973-1 Black Button	† 119243	Metal, Plain
* 20973-2 Red Button	† 119244	Metal, Red
* 20973-3 Green Button	† 119245	Metal, Green
* 20973-4 Yellow Button	† MP3651-7	Plastic, Red
		† (Buttons for -5 models only)

* Tolerance ring 20972 must be ordered with accessory buttons. (Replacement buttons for -1, -2, -3, -4 options only.)

Dimensional Data

Dimensions given in Inches and (Millimeters)

460 Series

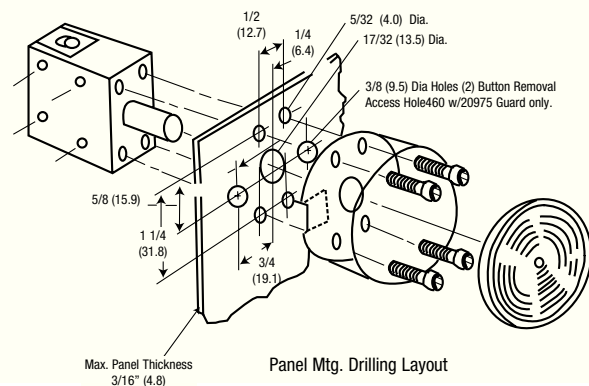
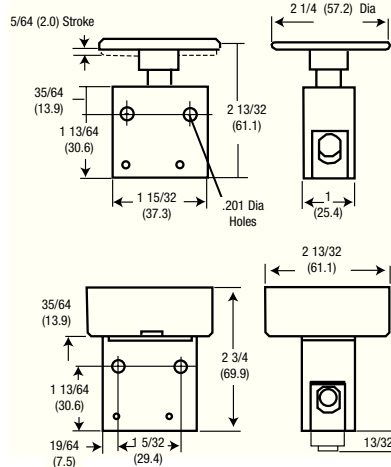

Features

Button Bleeders

- Provides remote control of bleeder pilot-operated valves.
- Reduces air pressure on valve, so valve can shift.
- Mounting blocks provide remote location of bleeder valve.
- 1/8" NPT thread. Maximum operating pressure of 150 PSIG (10.4 bar)

Pilot Bleeder Valve

- Similar to button bleeder valves, but operated by a pressure signal.
- 1/8" NPT threads. Operating Pressures 20-150 PSIG (1.4 - 10.4 bar)

Quick Exhaust Valves

- Provides quick dump of exhaust at cylinder.
- Eliminates need for large diameter piping or selector valves.
- Die cast aluminum body.

Single Pulse Relay Valve

- Converts continuous inlet supply to a momentary pressure pulse.
- Ideal where input signal remains pressurized, but output must go "off" after performing its task.
- Locate PR10 as close to pilot port of valve as possible.



24130

24135



9600



EV30-A



PR10

Dimensional Data Dimensions given in Inches and (Millimeters)

Button Bleeders

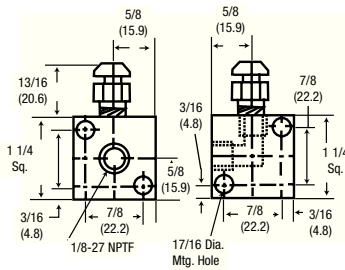

Quick Exhaust Valves

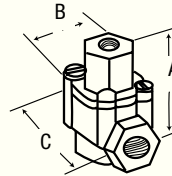

A	B	C
1 7/16 (36.5)	1 23/32 (43.7)	1 1/2 (38.1)
2 1/8 (54.0)	2 7/32 (56.4)	2 1/1 (52.4)
2 1/8 (54.0)	2 7/32 (56.4)	2 1/1 (52.4)
3 1/8 (79.4)	3 1/2 (88.9)	4 1/32 (102.4)
3 1/8 (79.4)	3 1/2 (88.9)	4 1/32 (102.4)

Single Pulse Relay Valve

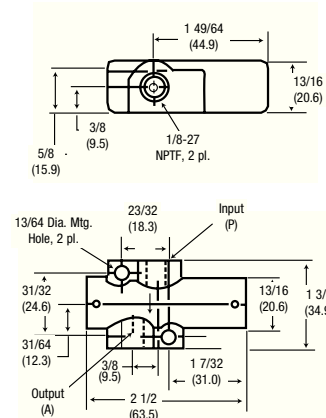

Performance Specifications/Ordering

Button Bleeders

Model Number	Description
24130	1/2" (12.7) Dia. Head
24135	1 1/8" (28.6) Dia. Head
24125	Mounting Block

Quick Exhaust Valves

Model Number	Inlet Port	Cyl. Port	Exh Port	Pres Range PSI (bar)
EV 125	1/8"	1/8"	1/4"	1-125 (.07-8.6)
EV 250	1/4	1/4	3/8	1-125 (.07-8.6)
EV 375	3/8	3/8	3/8	1-125 (.07-8.6)
EV 30-A	1/2	1/2	3/4	5-125 (.35-8.6)
EV 35-A	3/4	3/4	3/4	5-125 (.35-8.6)

Single Pulse Relay Valve

Supply Press. (bar)	PSIG (bar)	Pulse Duration	Reset Time
50	(3.5)	125ms	300 ms
75	(5.2)	110ms	300 ms
100	(6.9)	105ms	300 ms
125	(8.6)	100ms	300 ms

Features

Shuttle Valves

- Allows one of two input sources to get the output. Prevents either input from exhausting at other input source.
- Check ball moves from inlet with the greatest pressure and against the port having the least pressure. Minimum pressure difference of 10 PSIG(.7 bar) is necessary to effect shuttle change. 200 PSIG (13.8 bar) maximum.

Ordering

Shuttle Valves

Model Number	Inlet Ports	Outlet
SV10-C	1/8"	1/8"
SV20-C	1/4"	1/4"

Microswitch

20370 Microswitch Actuator

Pressure Range 25-125 PSIG (1.7-8.6 bar)
 Temperature Range 0-180 F (-18-82 C)

20467 Microswitch

Can be wired normally open or normally closed.
 Single pole, double throw:
 15 Amps, 125, 250 or 480 V-AC
 1/2 Amp, 125 V-DC; 1/4 Amp, 250 V-DC
 1/8 H.P., 125 V-AC; 1/4 H.P., 250 V-DC



SV20-C



20370

20467

Dimensional Data

Dimensions given in Inches and (Millimeters)

Shuttle Valves

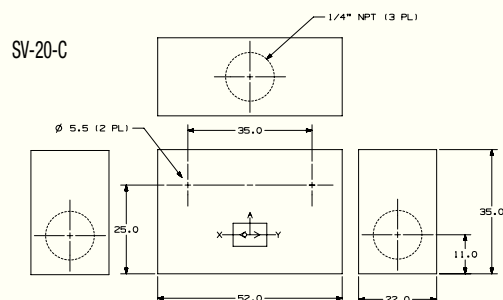
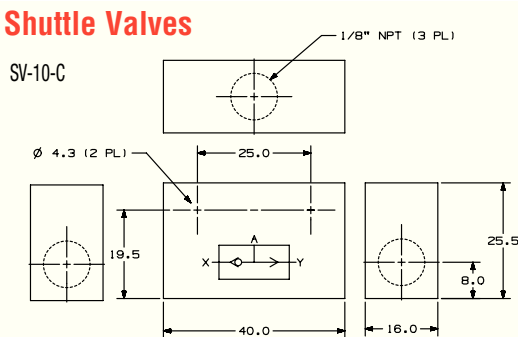

Microswitch

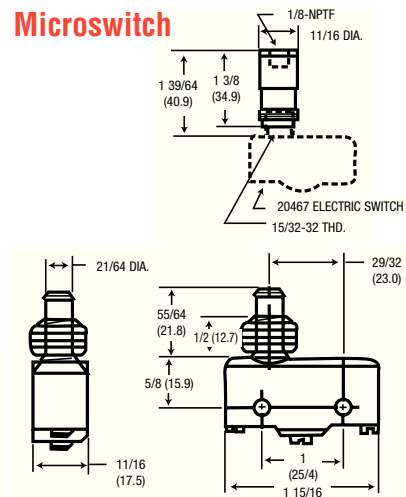

Features

Breather Vents

- Use on valves and single acting cylinders to prevent dirt from entering ports open to atmosphere. Other uses are for vacuum relief or pressure equalization on gear boxes, reservoirs and air tanks.
- 40 micron filtration. Selection based on thread size.
- Nickel plated steel body.



20311-X

Muffler

- Use on valve exhaust ports.
- Sintered bronze construction. Air muffler and exhaust diffuser.
- 40 micron nominal filtration; sound deadening qualities with low pressure drop.
- Nickel plated steel body.



20312-X

Speed Controls

- Controls air flow on exhaust ports of air valves.
- Change cylinder operating speed by adjusting screw. Secure with lock nut.



20313-X

Silencer

- Reduces noise of air powered motors and valves.
- For high SCFM applications. High flow, low back pressure with no build up.
- 300 PSI Max.



20308-X

Ordering

Breather Vents

Model Number	Port Size	Length In. (mm)	Hex
20311-1	1/8"	7/16 (11.1)	7/16
20311-2	1/4"	5/8 (15.9)	9/16
20311-3	3/8"	3/4 (19.1)	11/16
20311-4	1/2"	7/8 (22.2)	7/8
20311-6	3/4"	1 (25.4)	1-1/16
20311-8	1"	1-5/16 (33.3)	1-5/16

Speed Controls

Model Number	Port Size	Length Closed	Length Open In. (mm)
20313-1	1/8"	1 3/8 (34.9)	2 (50.8)
20313-2	1/4"	1 9/16 (39.7)	2 3/16 (55.6)
20313-3	3/8"	1 7/8 (47.6)	2 13/16 (71.4)
20313-4	1/2"	2 1/4 (57.2)	3 5/16 (84.1)
20313-6	3/4"	2 3/4 (69.9)	3 13/16 (96.8)
20313-8	1"	3 1/4 (82.6)	4 5/8 (117.5)

Muffler

Model Number	Port Size	Length In. (mm)	Hex
116464	10-32	23/32 (18.2)	5/16
20312-1	1/8"	1 1/8 (28.6)	7/16
20312-2	1/4"	1 3/8 (34.9)	9/16
20312-3	3/8"	1 1/2 (38.1)	11/16
20312-4	1/2"	1 7/8 (47.6)	7/8
20312-6	3/4"	2 1/4 (57.2)	11/16
20312-8	1"	1 7/8 (73.0)	1 5/16

Silencer

Model	Ports	Diameter	Length
20308-1	1/8"	13/16	2-1/8
20308-2	1/4"	13/16	2-1/4
20308-3	3/8"	1-1/4	3-7/16
20308-4	1/2"	1-1/4	3-9/16
20308-6	3/4"	2	5-3/8
20308-8	1"	2	5-1/2

Features

3-Way Sleeve Valve

- Provides low-cost on-off control of single-acting spring return cylinders.
- Use in both ports of double-acting cylinders to isolate from circuit.

Ordering

3-Way Sleeve Valve

Max. Press: 200 PSI (13.8 bar)

Temp Range: -25° - 200°F (-32° - 93°C)

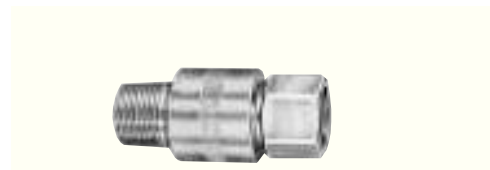

600-X

Model Number	Port Size	10 PSI Pressure Drop (SCFM)	
		100 PSI	80 PSI
600-1	1/8"	16	14.5
600-2	1/4"	40	36
600-3	3/8"	65	59
600-4	1/2"	140	127

Features

- 360° swivel eases tube alignment. Preapplied thread sealant.
- Choose threaded or instant tube fitting inlets; slotted or knob flow adjustment.
- Sturdy components include nickel-plated brass body, black anodized aluminum swivel, Buna-N seals and a stainless steel spring.
- Ready for installation on all ARO and competitive cylinders.
- Consult factory for BSP size models.



Ordering

SLOTTED ADJUST		KNOB ADJUST	
119307-XXX	119309-XXX	119308-XXX	119310-XXX
Male x Female thd	Male thd x fitting	Male x Female thd	Male thd x fitting
Description	Description	Description	Description
XXX Male x Female	xxx Male x Tubing	xxx Male x Female	XXX Male x Tubing
103 10-32x10-32	103 10-32 x 5/32"	125 1/8" x 1/8" NPT	120 1/8" x 5/32"
125 1/8" x 1/8" NPT	120 1/8" x 5/32"	250 1/4" x 1/4" NPT	125 1/8" x 1/4"
250 1/4" x 1/4" NPT	125 1/8" x 1/4"	375 3/8" x 3/8" NPT	250 1/4" x 1/4"
375 3/8" x 3/8" NPT	250 1/4" x 1/4"	500 1/2" x 1/2" NPT	255 1/4" x 3/8"
500 1/2" x 1/2" NPT	255 1/4" x 3/8"		375 3/8" x 3/8"
	375 3/8" x 3/8"		

Performance Specifications

Operating Pressure: 15-150 PSI (1-10 bar)
Operating Temperature: -32°F - 158°F

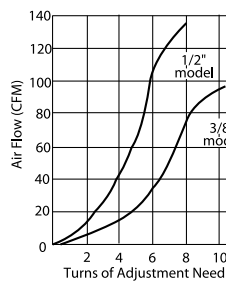
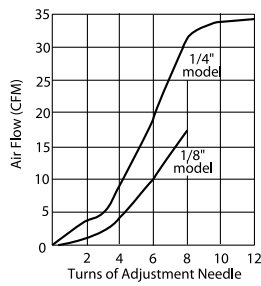
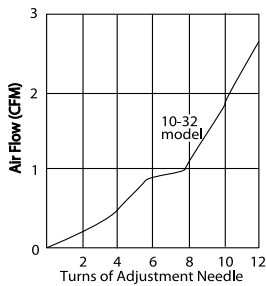
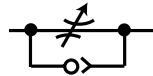

Dimensional Data

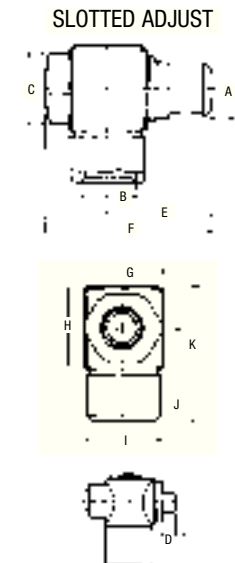
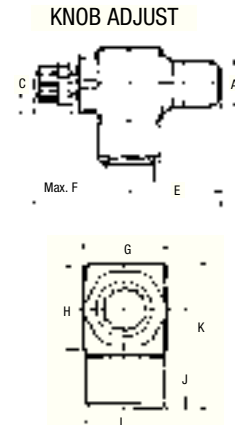

	PORT SIZE "A" & "B"	"C" inches (mm)	"D" inches (mm)	"E" inches (mm)	"F" inches (mm)	"G" inches (mm)	"H" inches (mm)	"I" inches (mm)	"J" inches (mm)	"K" inches (mm)
SLOTTED ADJUST	10/32	5/16 (8)	1/8 (3.2)	27/64 (11)	53/64 (21)	27/64 (11)	11/32 (9)	7/16 (11)	37/64 (14.7)	53/64 (21.1)
	1/8	1/2 (13)	0	25/32 (19.8)	1-17/64 (32)	19/32 (15)	19/32 (15)	33/64 (13)	47/64 (18.5)	1-3/64 (26.7)
	1/4	43/64 (17)	0	1-1/64 (25.8)	1-39/64 (41)	3/4 (19)	3/4 (19)	23/32 (18)	7/8 (22.5)	1-19/64 (32.9)
	3/8	7/8 (22)	0	1-9/64 (29)	1-27/32 (47)	29/32 (23)	29/32 (23)	29/32 (23)	1-1/8 (28.5)	1-39/64 (41)
	1/2	1-1/16 (27)	0	1-27/64 (36)	2-9/32 (58)	1-7/64 (28)	1-7/64 (28)	63/64 (25)	1-7/32 (31)	1-53/64 (46.3)
KNOB ADJUST	1/8	33/64 (13)	0	25/32 (19.8)	1-7/8 (47.5)	19/32 (15)	19/32 (15)	33/64 (13)	47/64 (18.5)	1-3/64 (26.7)
	1/4	43/64 (17)	0	1-1/64 (25.8)	2-9/32 (58)	3/4 (19)	3/4 (19)	45/64 (18)	57/64 (22.5)	1-19/64 (32.9)
	3/8	7/8 (22)	0	1-9/64 (29)	2-37/64 (65.5)	29/32 (23)	29/32 (23)	29/32 (23)	1-1/8 (28.5)	1-39/64 (41)
	1/2	1-1/16 (27)	0	1-27/64 (36)	3-5/32 (80)	1-7/64 (28)	1-7/64 (28)	63/64 (25)	1-7/32 (31)	1-53/64 (46.3)

Features

In-Line, Composite

- Four Stage, tapered needle design provides infinite control settings.
- Composite body is tough and corrosion resistant.
- Color-coded micrometer & calibrated adjustment knob provide instant reference points for repeat settings. Press red locking ring down prevents adjustment. Tamper resistant wire supplied in package.
- Units are threaded for easy remote panel mounting. Order panel nuts below.
- Needle Valve is available with stainless steel needle & inserts. Order 104104-NS2.

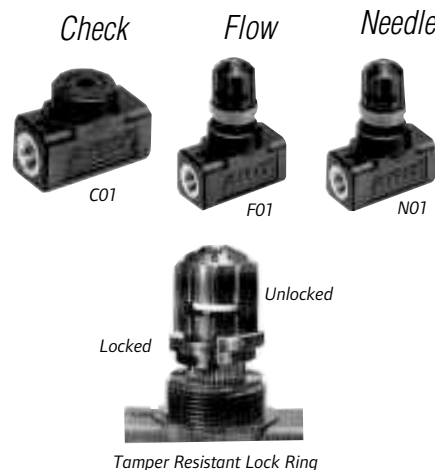

Ordering

		104104 - X XX			
Valve Type		Port Size			
Code	Description	Code	Description	Code	Description
C	Check Valve	01	1/8-27 NPTF	04	1/2-14 NPTF
F	Flow Control	02	1/4-18 NPTF	06	3/4-14 NPTF
N	Needle Valve	03	3/8-18 NPTF	* S2	1/4-18 NPTF Stainless Steel inserts & stem

* Available on needle valve only.

Panel Mounting Nuts	Port Size
104096	1/8" & 1/4"
104094	3/8", 1/2" & 3/4"

Performance Specifications

Operating Pressure:
200 PSI (13.8 bar)

Operating Temperature:
0° - 200°F (-18° - 93°C)

Flow:
100 PSI Inlet

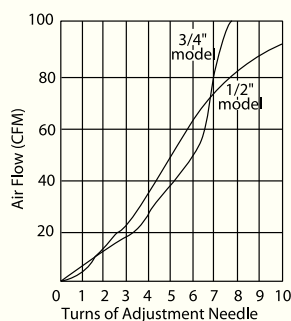
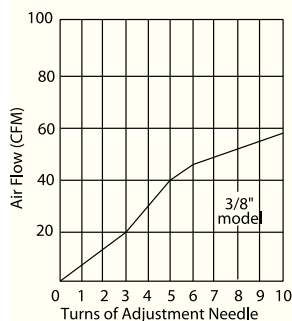
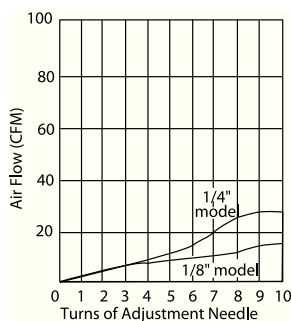

MODEL	PORT* NPT(F)	A	B	C		D	E	F
		inches (mm)	inches (mm)	Min.	Max.	inches (mm)	inches (mm)	inches (mm)
01	1/8-27	15/16 (23.8)	1-11/32 (34.1)	2-33/64 (63.9)	2-53/64 (71.6)	15/16 (23.8)	1-29/32 (48.4)	1-20 UNEF-2A
02	1/4-18	15/16 (23.8)	1-11/32 (34.1)	2-33/64 (63.9)	2-53/64 (71.6)	15/16 (23.8)	1-29/32 (48.4)	1-20 UNEF-2A
03	3/8-18	1-5/16 (33.3)	1-11/16 (42.9)	3-23/64 (85.3)	3-55/64 (97.8)	1-5/16 (33.3)	2-27/32 (72.2)	1-3/16-18 UNEF-2A
04	1/2-14	1-5/16 (33.3)	1-11/16 (42.9)	3-23/64 (85.3)	3-55/64 (97.8)	1-5/16 (33.3)	2-27/32 (72.2)	1-3/16-18 UNEF-2A
06	3/4-14	1-9/16 (39.7)	2 (50.8)	3-43/64 (93.3)	4-11/64 (105.7)	1-9/16 (39.7)	3 (76.2)	1-3/16-18 UNEF-2A

Dimensional Data

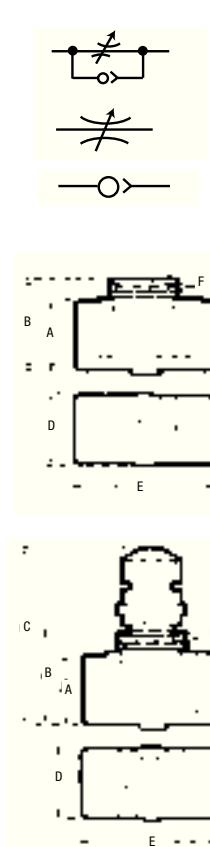

Features

In-Line, Brass

CPXX-B Check Valve

FXX-BK Flow Control

NXX-BK Needle Valve

- High Pressure (up to 2000 PSI) flow control for either pneumatic or hydraulic applications.
- Heavy-duty brass construction provides good corrosion resistance.
- Valve bodies, needle housings, locknuts & plugs are machined from brass stock.

• **Cracking Pressure**

CP10 - 1-1/2 PSI

CP20 - 1-1/2 PSI

CP25 - 2 PSI

CP30 - 3 PSI

CP35 - 4 PSI



Ordering

In-Line, Brass

Replace the "XX" with valve number corresponding to port size desired.

Example: F10-BK
Flow Control Valve
1/8" Ports

MODEL	VALVE NO. (XX)	NPTF PORT	P D HEX	E	L	G
	10	1/8	11/16	1-1/4	1-1/2	9/32
FXX-BK	20	1/4	7/8	1-1/4	2	5/16
NXX-BK	25	3/8	1-1/16	1-3/8	2-1/4	11/32
CPXX-B	30	1/2	1-5/16	1-3/8	2-21/32	3/8
	35	3/4	1-5/8	1-7/8	3	15/32

CP35-B Not available.

Dimensional Data

In-Line, Brass

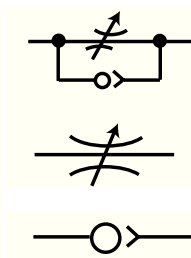
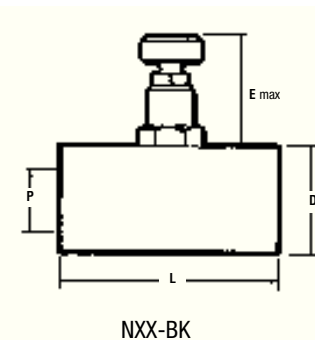
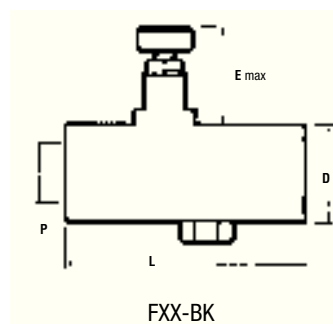
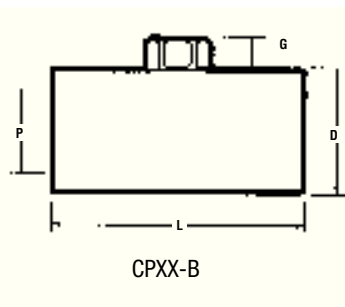

Features

Coils

- Coils are Class F rated for 100% duty cycle (311°F/155°C) applications.
- AC and DC coils are interchangeable on the same solenoid stem.
- Low “inrush” and “holding” current keeps heat rise to a minimum. This maximizes coil life and reduces power consumption.

Code / Voltage

-31 = 12V AC
 -33 = 120V AC
 -35 = 240V AC
 -37 = 5V DC

Code / Voltage

-38 = 24V AC or
 12V DC
 (22mm Coils only)
 -39 = 24V DC



Connectors

- Protect electrical connections from humidity and moisture. Meet NEMA 4 classifications
- Each is its own junction box, eliminating need to wire solenoid to another box.

Hazardous Location Coil

Coils are CSA certified and meet the requirements for use in hazardous locations. Environmental Code: Division 1, Class I, II, III, Group A-G
 FM Certification: 3006713
 Electrical Entry: 1/2" - 14 NPT-1 w/24" Lead Wires
 Class “H” rated, 100% duty cycle
 Available in 120V AC & 24V DC only



Ordering

Coils

(Replace XX on model number with coil voltage required.)

115046-XX Cable Coil (NEMA 4, 22mm)

10' AWG UL-listed elastomer cable. No solenoid connector needed.

115064-XX Low Watt Coil (DC only) (NEMA 4, 22mm)

Low DIN coil. DC only, for use with 3-prong connectors. 5, 12 and 24V DC only. Used only on valves ordered as low wattage.

116218-XX Standard Coil CSA & UL-listed (NEMA 4, 22mm)

AC or DC DIN coil for use with 3-prong connectors.

116647-XX Coil with Molded Leads CSA & UL-listed (NEMA 4, 22mm)

AC or DC lead wire coil with 18" molded leads. No solenoid connector needed.

*119690-XX Oversize (NEMA 4, 30 mm)

High Flow Cat Valve and 2-way Valve coil. Available in -32, -33, -35, -37, -38 and -39 voltages

* NOTE: -38 option is 12 VDC only on 30mm coils. 24 VAC is not available
 See Page 81 for Voltage Operating Ranges and Voltage Ratings.

Connectors

22-mm Connectors:

(Replace XXX with voltage and type from chart below)

- CHW** Straight connector with cable (36") located on top.
- CBW** Straight connector with cable (36") located on back.
- CHL-XXX** Straight connector (36") with indicator light located on back.
- CSN** Strain Relief, without indicator light or cable.
- CSL-XXX** Strain Relief with indicator light located on back.
- CDN** 1/2" Conduit without lights or lead wires.
- CDW** 1/2" Conduit without lights, 18" lead wires.
- CDL-XXX** 1/2" Conduit with light and 18" lead wires.

30-mm Connectors:

Use with High Flow Cat and intrinsically safe Genesis Valves

- CDW-30** Connector with wire.
- CSN-30** Connector, strain relief.
- CHW-30** Connector, molded cable.

Voltage (-XXX)

005 = 5V DC 120 = 120V AC
 012 = 12V AC/DC 240 = 240V AC/DC
 024 = 24V AC/DC

Performance Specifications

Coils

Coil Voltage Ratings	Voltage Operating Ranges	
	Operating Range $\pm 10\%$	
	AC	DC
5	--	4.5-5.5
2	11-13	11-13
24	22-26	22-26
120	108-132	108-132
240	216-264	--
380	342-418	--
22 mm Coil	Current (Amps)	Watts
5 DC	0.97	4.9
12 DC	0.38	4.8
24 DC	0.20	4.8
120 DC	0.04	4.8
5, 12, 24 DC	.05	1.1
30 mm Coil	Current (Amps)	Watts
12 DC	0-.62	15
24 DC	0.62	15
24 DC	(Hazardous Duty)	5

22 mm Coil Voltage Ratings

Coil Voltage Rating	50/60 Hz Current (Amps)		50/60 Hz Volt-Amps,	
	Inrush	Holding	Inrush	Holding
12AC	.70/.63	.50/.42	8.4/7.5	6.0/5.0
24AC	.46/.40	.36/.27	11.0/9.4	8.4/6.5
120AC	.09/.08	.07/.05	11.0/9.4	8.4/6.5
240AC	.05/.04	.04/.03	11.0/9.4	8.4/6.5
380AC	.03/.026	.024/.019	11.4/9.9	9.1/6.9

30 mm Coil Voltage Ratings

Coil Voltage Rating	50/60 Hz Current (Amps)		50/60 Hz Volt-Amps,	
	Inrush	Holding	Inrush	Holding
24AC	--	--	23	20
120AC	--	--	23	20
120AC	(Hazardous Duty)		11.5	8.5

Dimensional Data

Connectors

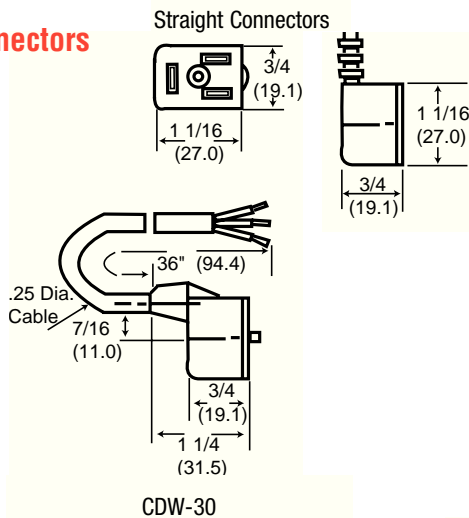

CSN 22 mm Strain Relief

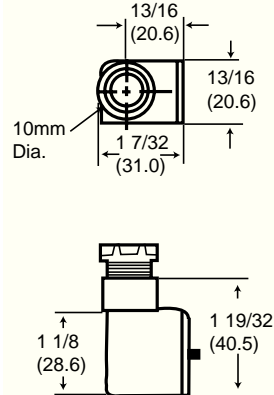

1/2" Conduit Connector

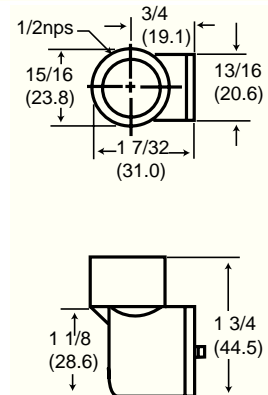

CSN-30 30 mm Strain Relief

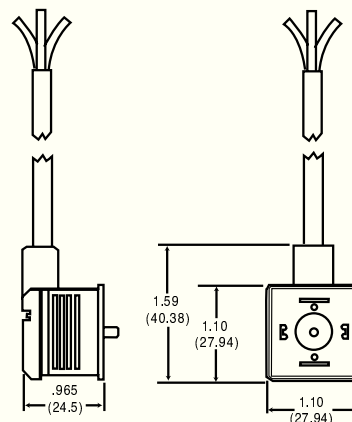
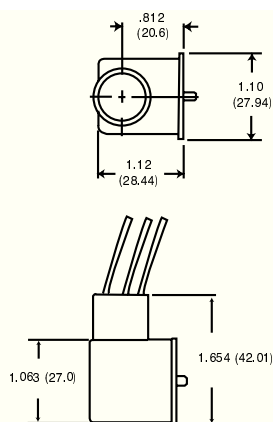
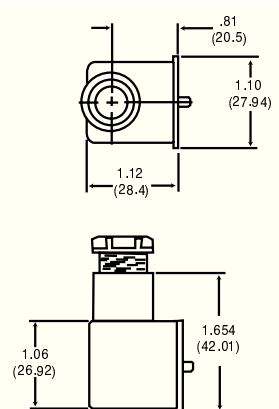

Features

Valve/Cylinder Manifold

- Mount any Alpha subbase valve to any NFPA cylinder
- Obtain maximum cylinder response and speeds
- Provides “clean” valve mounting method
- Mounts at cap or head end of cylinder
- Operates any NFPA Cylinder up to 2-1/2” bore
- Any stroke length (Minimum 3”)



Dimensional Data

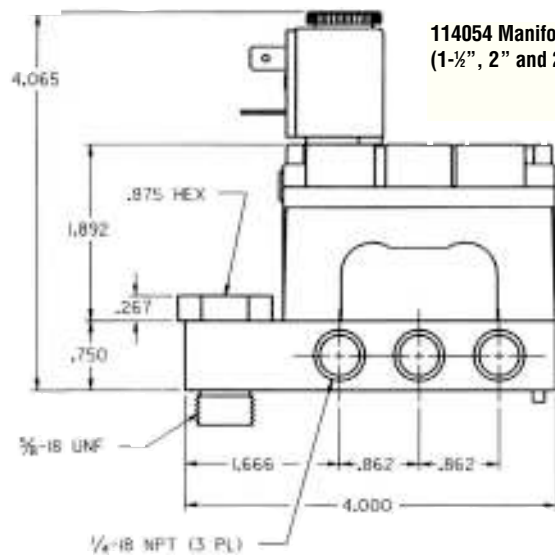

114054 Manifold Kit
(1-1/2", 2" and 2-1/2" bores)

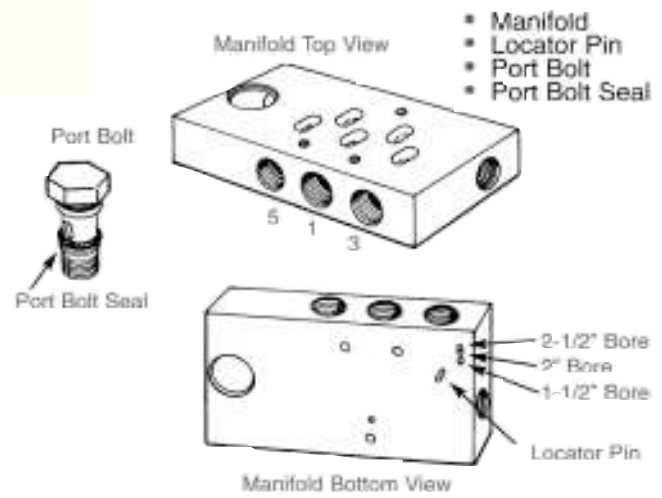

Ordering

Alpha Valves

Valve Model	Kit Number
All 2-Position, Spring Return, Urethane	118597-2
All 2-Position, Pilot or Solenoid Return, Urethane	118597-12
All 2-Position, Spring Return, Viton	118598-4
All 2-Position, Pilot or Solenoid Return, Viton	118598-14
3-Position, Closed, Urethane	118597-3
3-Position, Open, Urethane	118597-7
3-Position, Closed, Viton	118598-8
3-Position, Open, Viton	118598-9

Genesis Valves

GXXX XX - XXX - X

Plug-On Valves			Plug-In Valves		
Code	Rebuild Kit	Gasket Kit	Code	Rebuild Kit	Gasket Kit
GN12	118820-3	118824	GP12	118820-1	118823
GN13	118822-3	118824	GP13	118822-1	118823
GN14	118820-4	118824	GP14	118820-2	118823
GN17	118821-3	118824	GP17	118821-1	118823
GN18	118822-4	118824	GP18	118822-2	118823
GN19	118821-4	118824	GP19	118821-2	118823

Rebuild Kit selection is determined by the first four model numbers.
 [GX1X] XX-XXX-X (The positions within the brackets)

MaxAir Valves

Model	Repair Kit
M212LM	RKM212-LM
M212-LS	
M212PD	RKM212-PD
M212PS	RKM212-PS
M212SD-XXX-X	RKM212-SD
M212SS-XXX-X	RKM212-SS
M213LM	RKM213-LM
M213LS	RKM213-LS
M213PD	RKM213-PD
M213PS	RKM213-PS
M213SD-XXX-X	RKM213-SD
M213SS-XXX-X	RKM213-SS
M214-PD	RKM214-PD
M214PS	RKM214-PS
M214SD-XXX-X	RKM214-SD
M214SS-XXX-X	RKM214-SS
M2X2FS	114645
M2X2TM	114645
M312PD	RKM312-PD
M312SD-XXX-X	RKM312-SD
M313PD	RKM313-PD
M313SD-XXX-X	RKM313-SD
M314PD	RKM314-PD
M314SD-XXX-X	RKM314-SD

Sierra Valves

Model Number	Repair Kit
All Sierra Model 15	MQ3620
M812SS-XXX-X	RKM812-SS
M812SD-XXX-X	RKM812-SD
M813SD-XXX-X	RKM813-SD

50-Series Valves

Model Number	Repair Kit
All Models	7000

Genesis Pressure Regulators

Model	Rebuild Kit	Press Adj. Kit
118573-X2	119213	119212-30
118573-X3	119213	119212-60
118573-X4	119213	119212-120

E-Series Valves

Model	Repair Kit	Model	Repair Kit	Model	Repair Kit	Model	Repair Kit	Model	Repair Kit
E112HM	116772	E212JD	116702	E252BD	116773	E252LP	116772	E712LS	116773
E112LM	116772	E212KD-XXX-X	116702	E252BS	116772	E252LS	116772	E312SD-XXX	116773
E112PD	116773	E212KS-XXX-X	116702	E252CA	116772	E252PA	116772	E512LM	116772
E152HM	116772	E212LA	116772	E252CS	116772	E252PD	116773	E612LM	116772
E152LM	116772	E212LM	116772	E252CP	116772	E252PE	116772	E712SD-XXX-X	116773
E152PD	116773	E212LP	116772	E252FA	116772	E252PS	116772	Solenoid Operator	
E212BS	116772	E212LS	116772	E252FP	116772	E252RA	116772	E212KD-XXX-X	116575
E212BD	116773	E212PA	116772	E252FS	116772	E252RP	116772	E212KS-XXX-X	116573
E212CA	116772	E212PD	116773	E252GA	116772	E252RS	116772	E212SA-XXX-X	116573
E212CS	116772	E212PE	116772	E252GS	116772	E252SA-XXX-X	116772	E212SP-XXX-X	116573
E212CP	116772	E212PS	116772	E252HA	116772	E252SN-XXX-X	116772	E212SD-XXX-X	116575
E212FA	116772	E212RA	116772	E252HM	116772	E252SP-XXX-X	116773	E212SS-XXX-X	116573
E212FP	116772	E212RP	116772	E252HP	116772	E252SS-XXX-X	116772	E252KS-XXX-X	116573
E212FS	116772	E212RS	116772	E252HS	116772	E252TM	116772	E252SA-XXX-X	116573
E212HA	116772	E212SA-XXX-X	116772	E252JS	116702	E252UA	116772	E252SN-XXX-X	116573
E212HM	116772	E212SD-XXX-X	116773	E252JD	116702	E252US	116772	E252SP-XXX-X	116573
E212HP	116772	E212SP-XXX-X	116773	E252KS-XXX-X	116702	E312LS	116773	E252SS-XXX-X	116573
E212HS	116772	E212SS-XXX-X	116772	E252LA	116772	E312PD	116773	E312SD-XXX-X	116575
E212JS	116702	E212TM	116772	E252LM	116772	E312TS	116773	E712SD-XXX-X	116575

Ordering

H-Series

Model	Repair Kit	Model	Repair Kit	Model	Repair Kit	Model	Repair Kit
H212BD	7103	H214PD	7103	H243SD-XXX-X	7103	SOLENOID OPERATOR	
H212PA	7103	H214SA-XXX-X	7103	H252PS	7102	H212SA-XXX-X	116572
H212PD	7103	H214SD-XXX-X	7103	H252SS-XXX-X	7102	H212SD-XXX-X	116574
H212SA-XXX-X	7103	H242BD	7103	H253PS	7102	H213SA-XXX-X	116572
H212SD-XXX-X	7103	H242PA	7103	H253SS-XXX-X	7102	H213SD-XXX-X	116574
H213BD	7103	H242PD	7103	H254PS	7102	H214SA-XXX-X	116572
H213PA	7103	H242SA-XXX-X	7103	H254SS-XXX-X	7102	H214SD-XXX-X	116574
H213PD	7103	H242SD-XXX-X	7103	H282PS	7102	H242SA-XXX-X	116572
H213SA-XXX-X	7103	H243BD	7103	H282SS-XXX-X	7102	H242SD-XXX-X	116574
H213SD-XXX-X	7103	H243PA	7103	H283PS	7102	H243SA-XXX-X	116572
H214BD	7103	H243PD	7103	H283SS-XXX-X	7102	H243SD-XXX-X	116574
H214PA	7103	H243SA-XXX-X	7103	-	-	H252SS-XXX-X	116572
						H253SS-XXX-X	116572
						H254SS-XXX-X	116572
						H282SS-XXX-X	116572

K-Series

Model	Repair Kit	Model	Repair Kit	Model	Repair Kit	Model	Repair Kit	Model	Repair Kit	Model	Repair Kit
K213BS	7006	K233PD	7006	K244BD	7006	K314BD	7006	K713SD-XXX-X	7006	SOLENOID OPERATOR CONT.	
K213FP	7006	K233PS	7006	K244BS	7006	K334TS	7006	K713TS	7006	K234SD-XXX-X	116578
K213FS	7006	K233RS	7008	K244FP	7006	K336PD	7010	K714LS	7006	K234SS-XXX-X	116578
K213HS	7006	K233SD-XXX-X	7006	K244FS	7006	K336SD-XXX-X	7010	K714PD	7006	K236SD-XXX-X	116579
K213LM	7006	K233SS-XXX-X	7006	K244LM	7006	K338PD	7010	K714SD-XXX-X	7006	K236SS-XXX-X	116579
K213LS	7006	K233TM	7006	K244LS	7006	K338SD-XXX-X	7010	K714TS	7006	K238SD-XXX-X	116579
K213PD	7006	K234BD	7006	K244PD	7006	K343LS	7006	K716PD	7010	K238SS-XXX-X	116579
K213PS	7006	K234BS	7006	K244PS	7006	K343PD	7006	K716SD-XXX-X	7010	K243SD-XXX-X	116578
K213RS	7008	K234FP	7006	K244RS	7008	K343SD-XXX-X	7006	K718PD	7010	K243SS-XXX-X	116578
K213SD-XXX-X	7006	K234FS	7006	K244SD-XXX-X	7006	K343TS	7006	K718SD-XXX-X	7010	K244SD-XXX-X	116578
K213SS-XXX-X	7006	K234LM	7006	K244SS-XXX-X	7006	K344LS	7006	K733PD	7006	K244SS-XXX-X	116578
K213TM	7006	K234LS	7006	K244TM	7006	K344PD	7006	K733LS	7006	K246SD-XXX-X	116579
K214BS	7006	K234PD	7006	K246BD	7010	K344SD-XXX-X	7006	K733SD-XXX-X	7006	K246SS-XXX-X	116579
K214BD	7006	K234PS	7006	K246BS	7010	K344TS	7006	K733TS	7006	K248SD-XXX-X	116579
K214FP	7006	K234RS	7008	K246PD	7010	K346PD	7010	K734PD	7006	K248SS-XXX-X	116579
K214FS	7006	K234SD-XXX-X	7006	K246PS	7010	K346SD-XXX-X	7010	K734LS	7006	K313SD-XXX-X	116578
K214LM	7006	K234SS-XXX-X	7006	K246RS	7012	K348PD	7010	K734SD-XXX-X	7006	K314SD-XXX-X	116578
K214LS	7006	K234TM	7006	K246SD-XXX-X	7010	K348SD-XXX-X	7010	K734TS	7006	K316SD-XXX-X	116579
K214PS	7006	K236BD	7010	K246SS-XXX-X	7010	K513LM	7007	K736PD	7010	K318SD-XXX-X	116579
K214PD	7006	K236BS	7010	K248BD	7010	K513TM	7007	K736SD-XXX-X	7010	K333SD-XXX-X	116578
K214RS	7008	K236PD	7010	K248BS	7010	K514LM	7007	K738PD	7010	K334SD-XXX-X	116578
K214SD-XXX-X	7006	K236PS	7010	K248PD	7010	K514TM	7007	K738SD-XXX-X	7010	K336SD-XXX-X	116579
K214SS-XXX-X	7006	K236RS	7012	K248PS	7010	K533LM	7007	K743LS	7006	K338SD-XXX-X	116579
K214TM	7006	K236SD-XXX-X	7010	K248RS	7012	K533TM	7007	K743SD-XXX-X	7006	K343SD-XXX-X	116578
K216BD	7010	K236SS-XXX-X	7010	K248SD-XXX-X	7010	K534LM	7007	K743TS	7006	K344SD-XXX-X	116578
K216BS	7010	K238BS	7010	K248SS-XXX-X	7010	K534TM	7007	K744LS	7006	K346SD-XXX-X	116579
K216PD	7010	K238BD	7010	K313LS	7006	K543LM	7007	K744PD	7006	K348SD-XXX-X	116579
K216PS	7010	K238PD	7010	K313PD	7006	K543TM	7007	K744SD-XXX-X	7006	K713SD-XXX-X	116578
K216RS	7012	K238PS	7010	K313TS	7006	K544LM	7007	K744TS	7006	K714SD-XXX-X	116578
K216SD-XXX-X	7010	K238RS	7012	K314LS	7006	K544TM	7007	K746PD	7010	K716SD-XXX-X	116579
K216SS-XXX-X	7010	K238SD-XXX-X	7010	K314PD	7006	K613LM	7007	K746SD-XXX-X	7010	K718SD-XXX-X	116579
K218BD	7010	K238SS-XXX-X	7010	K314SD-XXX-X	7006	K613TM	7007	K748PD	7010	K733SD-XXX-X	116578
K218BS	7010	K243BD	7006	K314TS	7006	K614LM	7007	K748SD-XXX-X	7010	K734SD-XXX-X	116578
K218PD	7010	K243BS	7006	K316PD	7010	K614TM	7007	SOLENOID OPERATOR			
K218PS	7010	K243FP	7006	K316SD-XXX-X	7010	K633LM	7007	K213SD-XXX-X	116578	K738SD-XXX-X	116579
K218RS	7012	K243FS	7006	K318PD	7010	K633TM	7007	K213SS-XXX-X	116578	K743SD-XXX-X	116578
K218SD-XXX-X	7010	K243LM	7006	K318SD-XXX-X	7010	K634LM	7007	K214SD-XXX-X	116578	K744SD-XXX-X	116578
K218SS-XXX-X	7010	K243LS	7006	K333LS	7006	K634TM	7007	K214SS-XXX-X	116578	K746SD-XXX-X	116579
K233BD	7006	K243PD	7006	K333PD	7006	K643LM	7007	K216SD-XXX-X	116579	K748SD-XXX-X	116579
K233BS	7006	K243PS	7006	K333SD-XXX-X	7006	K643TM	7007	K216SS-XXX-X	116579		
K233FP	7006	K243RS	7008	K333TS	7006	K644LM	7007	K218SD-XXX-X	116579		
K233FS	7006	K243SD-XXX-X	7006	K334LS	7006	K644TM	7007	K218SS-XXX-X	116579		
K233LM	7006	K243SS-XXX-X	7006	K334PD	7006	K713LS	7006	K233SD-XXX-X	116578		
K233LS	7006	K243TM	7006	K334SD-XXX-X	7006	K713PD	7006	K233SS-XXX-X	116578		

Features

Aro Pneumatic Logic Control Overview

Elements: Elements are miniature diaphragm operated poppet valves designed to perform specific functions. This includes “Or,” “And,” “Not,” plus various “Memory” and “Delay” functions. Elements are designed so response times, shift ratios, flow and exhaust capacities are closely matched and all are compatible in a total system. This compatibility simplifies circuit design.

Circuit Board Construction: Aro’s patented circuit board construction uses a gasket and two metal plates to create a custom air manifold. Interconnections between the elements are cut into the gasket (module) and sealed between the metal plates. The result is a completely interconnected circuit without tubing or fittings. Two gasket modules are used for more complex circuits. Circuit Boards produce a smaller circuit package at lower cost; increased tamper resistance; and provide a clean, neat assembly.

Function Base Assembly Method: A Function Base can be used when circuits require four or less elements. This consists of a gasket module, a thin metal plate and a porting strip. Interconnections between the elements are cut into the module. The porting strip has 1/8” NPTF ports, eliminating the need for porting blocks. This method can be mounted on any flat surface; it provides a neat, durable assembly; and it increases tamper resistance.

Back Tubulation Construction: This method uses a thin metal plate (base plate) and porting blocks for each element. Each block has built in fittings for 5/32” (4mm) tubing. Element interconnections are made by connecting tubes to these fittings. Back tubulation is often used for “bread boarding” new circuits, air circuit training and if circuits are frequently changed.



Individual Elements



Circuit Board Construction



Function Base Assembly



Back Tubulation

Performance Specifications

Air Supply Preparation

Recommended Filtration: Filter air with a 40 micron filter or better. Additional screens in the base of timing function elements and amplifiers prevent large particles from entering the element.

Recommended Lubrication: None required for individual elements, or for circuits including timing functions or amplifiers.

Moisture: All metal parts are chromate plated to resist corrosion from moisture and many chemicals. A dry air supply is recommended for maximum repeatability of timing and sensing functions.

Operating Air:

Operating Pressure: 30-150 PSI (2-10 bar). Two-hand anti-tie-down devices require 50-125 PSI (3.5-9 bar).

Shift Pressures:

Snap-Acting Elements (And, Not, Inhibitor, S/R -- Mem, Delay and Pulse) shift when the pilot pressure exceeds 70% of the supply. They return when pilot pressure is less than 40% (Inhibitor 5%) of the supply.

Non-Snap-Acting Elements (Or -- Flip-Flop) have a shift pressure of 50% of supply pressure.

Flow & Cv Factors:

Dependent on specific elements and flow paths.
Flow = 9.3-16.2 SCFM, Cv = .14-.28

Identification:

Symbols: Each element has a symbol based on the National Standard for diagramming moving part logic control (attached method).

Port Identification: Letters cast into the cover and base of each element correspond to input and output designations.

Mounting: Elements have 5/8” (15.9mm) bolt extensions. All mounting hardware and seals are provided with each element.

Test Ports: Many elements have 1/8” NPT ports connected to the “C” (output) port. These can be used as optional output ports, or as test ports.

Anticipated Life:

Element Life: APLC elements have proven extremely durable, operating many millions of cycles, or several years, without failure. If needed, repair kits or parts are available for most elements.

Features

- Ideal for machines where position of operator’s hands must be monitored.
- Actuate and hold both air valve buttons concurrently to maintain an output air signal. If either push button is released, the output air signal is exhausted, indicating the operator’s hands are no longer in position.
- Operating Pressures: 50-125 PSI (3.5-8.6 bar). Designed to comply with OSHA regulations.

Warning: These provide only the anti-tie down logic function and are not stroke limiting devices. On machines with full revolution clutches and/or where repeat cycles can occur, approved safety and/or single stroke devices must be used in conjunction with the anti-tie down units.

Elements

59191 Base Mounted

- Element has three 1/8” NPTF ports on top. 2 inputs, 1 output.
- Element is base mounted.
- See page 101 for additional information

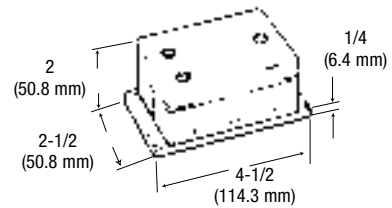

Packages

59808

- Includes two enclosures with green push button valves separated by a length of flexible conduit. External supply and output to machine is made by 5/32” (4mm) instant tube fittings.
- Comes assembled with all internal connections ready to install on machine.
- Palm Buttons are 30” center to center.

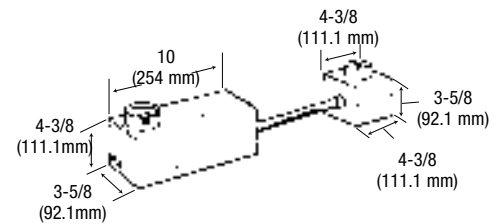
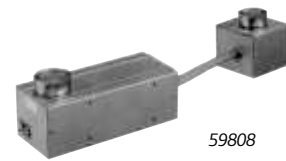

59809

- Green push buttons located on opposite ends of a single enclosure. External supply and output to machine is made by 5/32” (4mm) instant tube fittings.
- Comes assembled with all internal connections ready to install on machine.

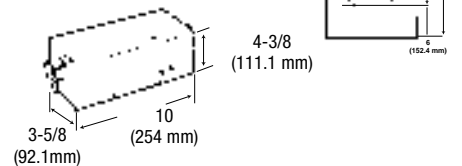

59003-842

- Unassembled package.
- Includes 59191 anti-tie-down block, two 461-3 palm buttons with 20975 guards, 10 feet of 5/32” tubing and fittings for 59191.
- Customer can custom fit components to machine.

59003-842 CONTROL ASM.
10' of 5/32" Tubing

59756*4 (3) BOW FITTINGS FOR 5/32" TUBING

59191 LOGIC CONTROL ASM.

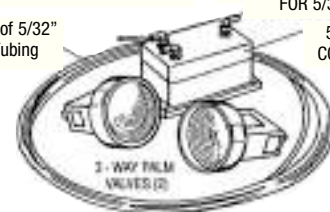

Features

Flex 6

Designed to Control Sequential Type Machines

- Simplifies design & installation of control circuits.
- Circuit changes or additions can be accomplished in seconds.
- Very economical for simple air operated machines and fixtures.
- Ideal for harsh and explosive environments.
- All ports are 10/32 threads.
- Use filtered, dry, non-lubricated air. 50-125 psi (3.5-8.6 bar)

Set/Reset Memory: The first step in each Flex-6 circuit is controlled by a set/reset memory. A momentary start signal pressurizes the set port, causes the memory to go on and starts the sequence. The memory remains on until the reset port is pressurized (end of cycle or emergency stop). Loss of supply pressure also resets the memory (output off).

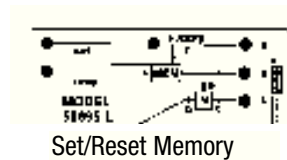

Automatic Reset Memory: Other Flex-6 memory functions automatically reset. A momentary signal at the set port causes the memory output to go on, provided the previous stage is on. The output will remain on until the entire circuit is reset. This memory has the ability to ignore signals arriving at the wrong time and will reset regardless of the set input condition. You don't need to analyze if the set signal is momentary or maintained, nor are you required to connect limit valves in series with a previous output.

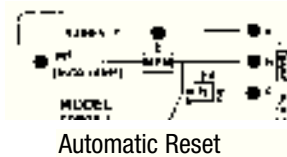

Timer Adjustment: Each time delay has a numbered dial (the numbers act as reference only). Screwdriver adjustment and fixed delay models are available on special order.

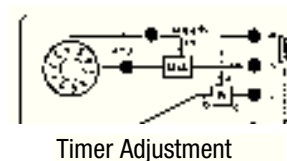

Adjustment Range: The recommended adjustment range is .1 to 3 seconds. If normal operating time is longer than 3 seconds, additional volume should be connected to the port marked "ACU." Each cubic inch additional volume connected to this port increases maximum time delay by 8 seconds.

Sequence Controlled with Input Signals: If all steps are started by input signals, use one 59897 start/stop unit and an additional 59898 unit as required to complete the sequence.

Sequence Controlled by Time Delay Functions: If all steps are started by time delay (with the exception of the start button) use one piece 59895 start/stop unit and an additional 59896 to complete the sequence.

Both Input, Inhibit and Time Delay used to Control a Sequence: Mixed circuits are easily accomplished by selecting from the units previously mentioned, plus two more. Models 59899 and 59900 provide a combination of a time delay and an input signal functions in a single unit. Using the 59899 and 59900 gives you the exact unit needed for all mixed circuits.

Inhibitor: Inhibitor models (59920 through 59925) are used as the first, second or later circuit, depending on the application requirements.

Set-Up

Steps to Connecting Flex-6 Units

1. Arrange the units in the order and sequence they are used (steps 1 & 2 top, 3 & 4 next, etc.).
2. Connect a maintained supply to the “supply in” port of the first unit. Then connect the “supply out” of the first unit to the “supply in” of the second unit. Connect subsequent units in this manner. The last “supply out” port will remain plugged.
4. Connect and “program” the outputs. Each unit has three ports on the right side marked “A,” “B,” and “C.” The “C” port is the output and is connected to the pilot valve or other device causing action for each stage. The “C” output signal can be removed by a signal (maintained) to the “A” port. The “B” ports are used to provide this maintained signal.
5. Connect the reset signal from the last step in sequence to the port marked “reset” in the first. This signal resets the circuit, making it ready to start a new cycle.

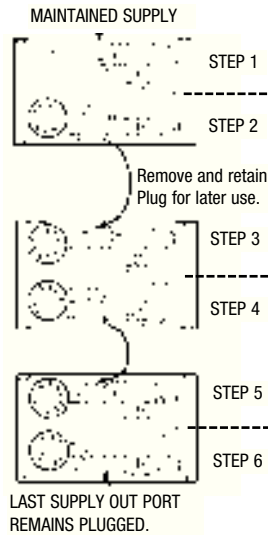

3. Connect the set input signals. The start signal and all other input signals are connected to the set ports of the units they will start.

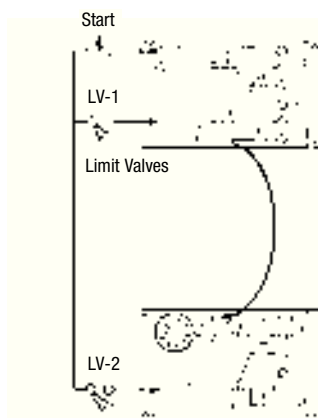

Example: Cylinder 1 extends in step 1 and retracts in step 4. The “C” port of step 1 is connected to a spring return pilot valve which extends the cylinder. The “B” port of step 4 is connected to the “A” port of step 1. This accomplishes the retract function.

NOTE: Once these connections have been made, plug all “B” and “C” ports not used. **“A” ports not used remain open.**

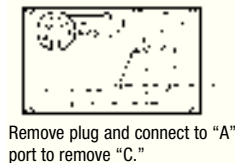
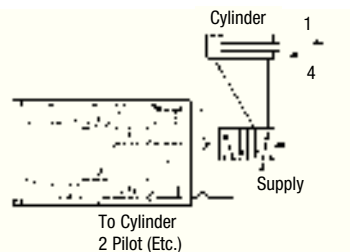

First Unit



All Ports are 10/32 Threads

Features

Individual Units

59895 S/R Mem-Delay Model

The first unit in a Flex-6 circuit when step two is a delay function. The first output is caused by the start input signal. The second output is caused by a time delay following the first output. Flex 6 Dimensional Data is located on Pg. 86.

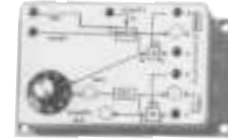

59895

59896 Double Delay

Used as the second unit, or later, in circuits when two time delay functions are needed. The first output is caused by a time delay after the supply signal is applied. The second output is caused by a time delay following the first output. Flex 6 Dimensional Data is located on Pg. 86.

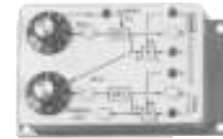

59896

59897 S/R Mem-Auto Mem Model

The first unit in Flex-6 circuits when step two is an input signal. The first output is caused by the start input signal. The second output is caused by a second input signal. Flex 6 Dimensional Data is located on Pg. 86.

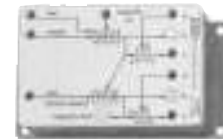

59897

59898 Double Auto Mem Model

Used as the second unit, or later, in circuits when two input signals are available. Both outputs are caused by their respective inputs and both are controlled by automatic reset memory functions. Flex 6 Dimensional Data is located on Pg. 86.

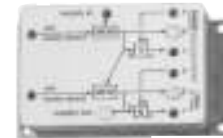

59898

59899 Auto Mem-Delay Model

Used as the second unit, or later, in Flex-6 circuits when an input signal and a delay function are required. The first output is caused by an input signal. The second output is caused by a time delay following the first output. Flex 6 Dimensional Data is located on Pg. 86.

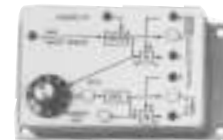

59899

59900 Delay-Auto Mem Model

Used as the second unit, or later, in circuits when a delay and an input signal are required. The first output is caused by delay function after the supply signal is applied. The second output is caused by an input signal. Flex 6 Dimensional Data is located on Pg. 86.

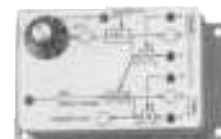

59900

Features

Individual Units

59919-1 Cycle Repeat Circuit

Cycle Repeat Circuit provides continuous recycling of a control circuit started by a momentary start signal, end of cycle stop — momentary input, single cycle operation, emergency stop and an adjustable dwell between cycles.

Add to any Flex-6 circuit so it cycles continuously.

Flex 6 Dimensional Data is located on Pg. 86.

See page 102 for additional information.



59919-1

59920 S/R Mem-Inhibitor Model

The first Flex-6 circuit when step two is an inhibitor function. The first output is caused by the start input signal. The second output is caused by the release of pressure on the inhibitor port.

Flex 6 Dimensional Data is located on Pg. 86.



59920

59921 Inhibitor-Input Model

Used as the second or later circuit when the first stage will be controlled by an inhibitor signal and the second from a pressure signal.

Flex 6 Dimensional Data is located on Pg. 86.



59921

59922 Delay-Inhibitor Model

Used as the second or later circuit when the first stage will be controlled by a delay and the second from an inhibitor signal.

Flex 6 Dimensional Data is located on Pg. 86.



59922

59923 Double Inhibitor Mem Model

Used as the second or later circuit when both stages are started by inhibitor signals.

Flex 6 Dimensional Data is located on Pg. 86.



59923

59924 Input-Inhibitor Model

Used as the second or later circuit when the first stage will be controlled by a pressure signal and the second from an inhibitor signal.

Flex 6 Dimensional Data is located on Pg. 86.

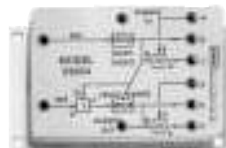

59924

59925 Inhibitor-Delay Model

Used as the second or later circuit when the first stage will be controlled by an inhibitor signal and the second from a delay.

Flex 6 Dimensional Data is located on Pg. 86.

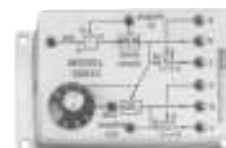

59925

Illustration 1

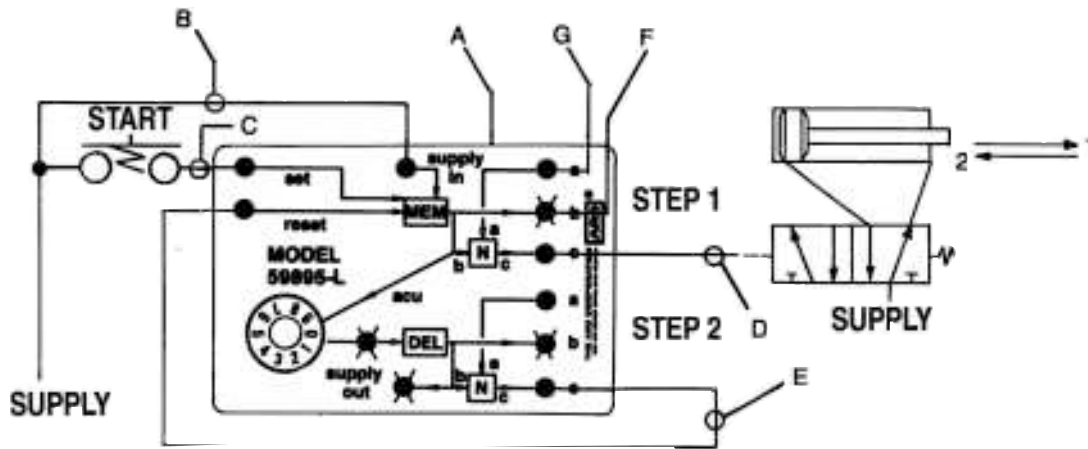

Description

Here we have a two step sequence using one cylinder. When a push button is actuated, the cylinder will extend for an adjustable period of time. When the time has elapsed, the cylinder will retract to its original position.

Connections

- A. This sequence uses a model 59895 Flex-6 unit.
- B. Supply is connected to the "Supply In" port.
- C. The output of a start push button is connected to the "Set" input port.
- D. The step 1 output (top "c" port) is connected to the pilot port of the valve which will extend the cylinder.
- E. The step 2 output (lower "c" port) is connected to the "Reset" input port.
- F. Both "b" ports, the "Supply Out" port, and the "ACU" port are plugged (new units are shipped with these plugs installed.)
- G. "a" ports, not used, remain open.

Function

1. At rest, the cylinder is retracted.
2. The operator presses the start push button. This signals the set port and step 1 output goes on immediately. The cylinder extends and the time delay is started. At this point the signal is "Locked In" and the operator can release the start push button. The time delay is adjustable. Turning the dial clockwise, extends the time setting.
3. When the adjusted time is expired, step 2 output goes on. Step 2 output signals the reset port. This causes the Flex-6 unit to reset* (unlocks the start signal) and outputs 1 and 2 go off., causing the cylinder to retract.
4. The circuit is now reset and ready for a new cycle when the start push button is again actuated.

*Set signal must be off for this to take place.

Illustration 2

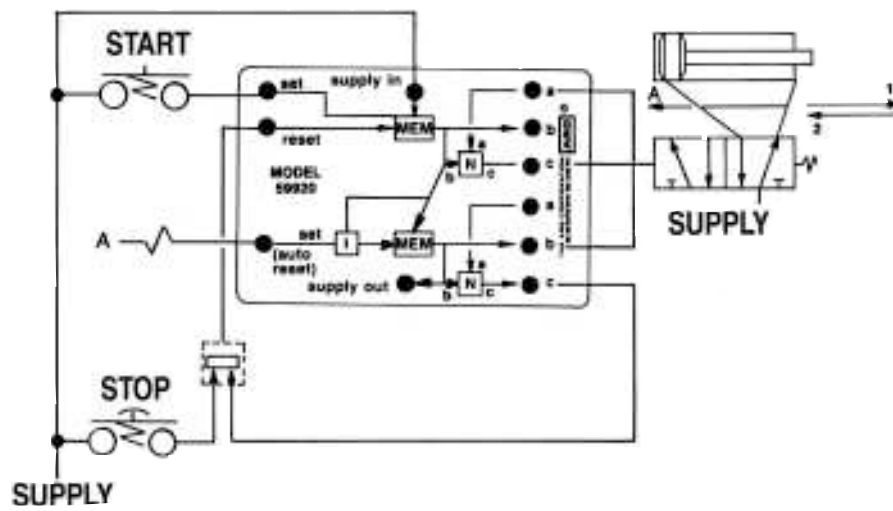

Description

Here we have a two step sequence described in Illustration 1. The difference is that the extension of the cylinder is sensed by the inhibitor element built into the 59920 Flex-6 unit. Again, when the cylinder is fully extended, the cylinder will retract.

Connections

- This sequence uses a model 59920 Flex-6 unit.
- The "A" connection is made from between the valve and the cylinder to the second set input.
- All other connections are identical to those made in Illustration 1, except that we have added a connection from "b" of step 2 to "a" of step 1. This will make the cylinder retract even if the operator continues to hold the button.

Options

The additional connection from the "b" port of the second stage at the "a" port of the first stage insures that the cylinder will return even if the operator continues to hold the start button.

An emergency stop push button has also been added. If the operator presses the emergency stop button, the circuit will reset and both cylinders will retract.

Function

- At rest, the cylinder is retracted.
- The operator presses the start push button. This signals the set port and step 1 output goes on. The operator can now release the start button.
- The cylinder now extends, and when fully extended or stopped mechanically, the signal at the second set port is fully released. This causes the step two output to go on retracting the cylinder and resetting the circuit.

Illustration 3

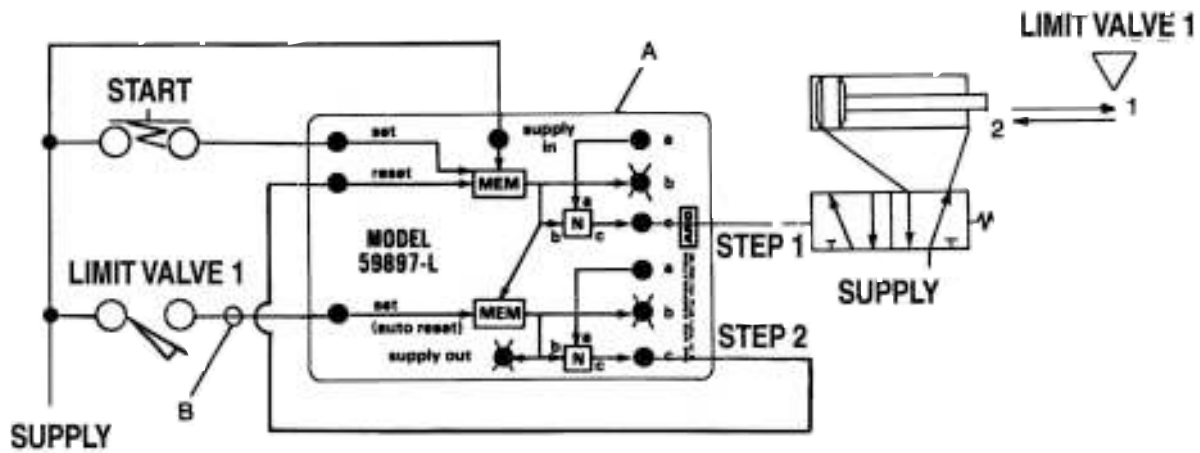

Description

Here we have a two step sequence described in Illustration 1. The difference is that this cylinder actuates a limit valve when it is fully extended. The limit valve signals the Flex-6 unit that the cylinder is extended and it is time to retract.

Connections

- A. This sequence uses a model 59897 Flex-6 unit.
- B. The limit valve output is connected to the port marked Set (Auto Reset)
- C. All other connections are identical to those made in Illustration 1.

Options

Option A, preventing the operator from holding the cylinder extended and Option B, providing an optional retract push button could be added to this circuit. These options are described in Illustration 2.

Function

1. At rest, the cylinder is retracted.
2. The operator presses the start push button. This signals the set port and step 1 output goes on immediately. At this point, the signal is “Locked In” and the operator can release the start push button.
3. The cylinder actuates the extend limit valve (LV-1). Limit valve 1 signals the step 2 set port. This causes the step 2 output to go on immediately. The step 2 output signals the reset port, which resets the circuit* removing the step 1 and 2 outputs and allows the cylinder to retract.

* Set signal must be off for this to take place.

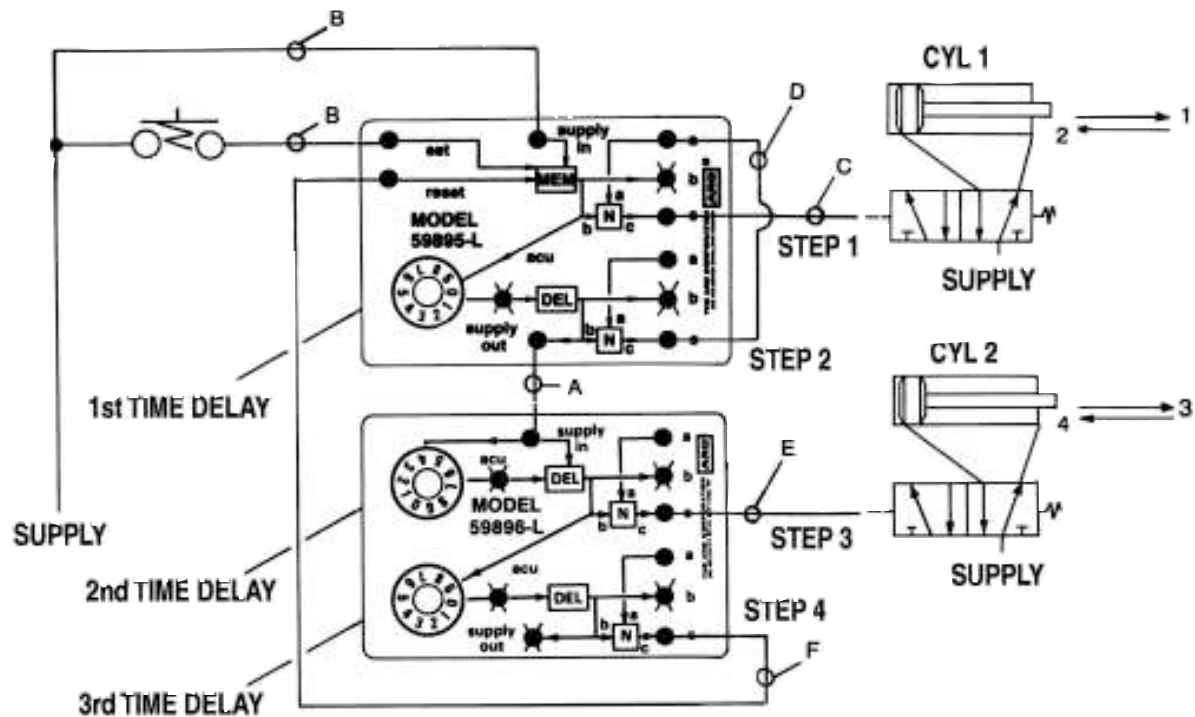
Illustration 4

Description

Here we have a two cylinder four step sequence.

1. When the push button is actuated, cylinder 1 extends. This also starts the first time delay.
2. When the first time delay times out, cylinder 1 retracts. This starts the second time delay.
3. When the second time delay times out, cylinder 2 extends. This starts the third time delay.
4. When the third time delay times out, cylinder 2 retracts. This also resets the circuit.

Connections

This circuit uses a model 59896 Flex-6 unit.

- A. The 59896 is added to the circuit simply by removing the "Supply Out" plug in the 59895 and connecting this port to the "Supply On" port of the 59896.
- B. The supply and start push buttons are connected as before.
- C. The step 1 output is connected to the valve that extends cylinder 1.
- D. The step 2 output is connected to the "a" port of step 1.
- E. The step 3 output is connected to the valve that extends cylinder 2.
- F. The step 4 output is connected to the reset port.
- G. All "b" ports, all accumulator ports and the supply out of the 59896 are plugged.
- H. All "a" ports not used are left open.

Function

Looking closely at the diagram on top of the Flex-6 units, you may be able to trace the signals as the sequence progresses.

1. When the operator presses the start push button the signal sets the memory (MEM) in the first unit (MEM output on). This goes thru a "not" (N) element and to the step 1 output (CYL 1 extends). The output from the memory element is also connected to the first time delay by a diagonal line.
2. The output of delay 1 again goes through a "not" element to provide the step 2 output. This output is connected externally to the "a" input of step 1 and internally to the "a" port of the "not" element. This removes the output signal at step 1 and retracts cylinder 1. The output of delay 1 is also connected to the second time delay via the "supply out" to "supply in" connection.
3. Time delay 2 extends cylinder 2 and starts time delay 3.
4. Time delay 3 outputs resets the entire circuit and in doing so retracts cylinder 2.

Illustration 5

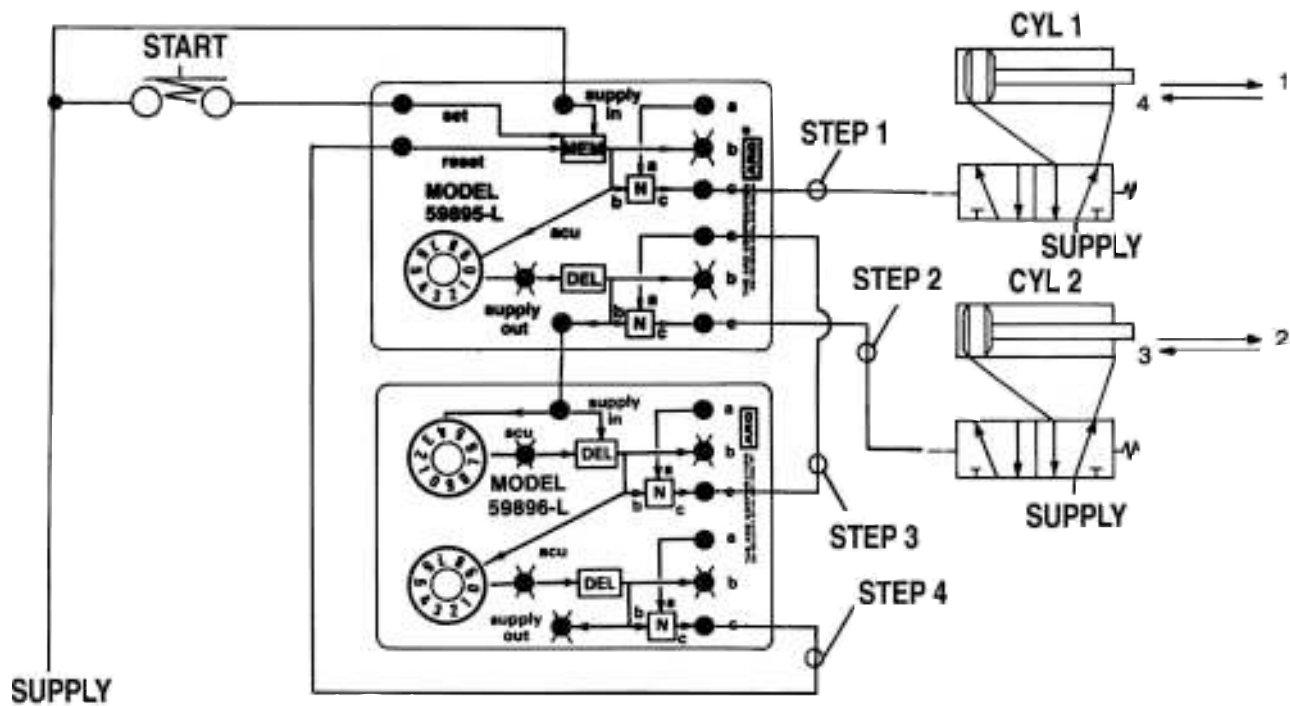

Description

Here we have a circuit similar to the one shown in Illustration 4. The difference between these circuits is the sequence that the cylinders extend and retract. This is shown by the numbered arrows to the right of the cylinders.

Connections

Notice that the change in sequence is done entirely by changing the output connections on the right hand side of the Flex-6 units.

- A. Step 1 output is connected to the valve that extends cylinder 1 (as before).
- B. Step 2 output is connected to the valve that extends cylinder 2.
- C. Step 3 output is connected to the “a” input port of step 2. This removes the step 2 output and retracts cylinder 2.
- D. Step 4 output is connected to the reset port (as before).

Thus by rearranging the output connections any sequence can be performed.

Options

- 1. To prevent the operator from holding cylinder 1 extended (by holding down the start push button), a connection can be made from the “b” port of step 4 to the “a” port of step 1.
- 2. An emergency retract push button can be added (See Illustration 2).
- 3. Additional accumulator and/or gauges can be added to each time delay (See Illustration 2).
- 4. Sequence step indicators can be added to the “b” ports (Model 59907-004).

Illustration 6

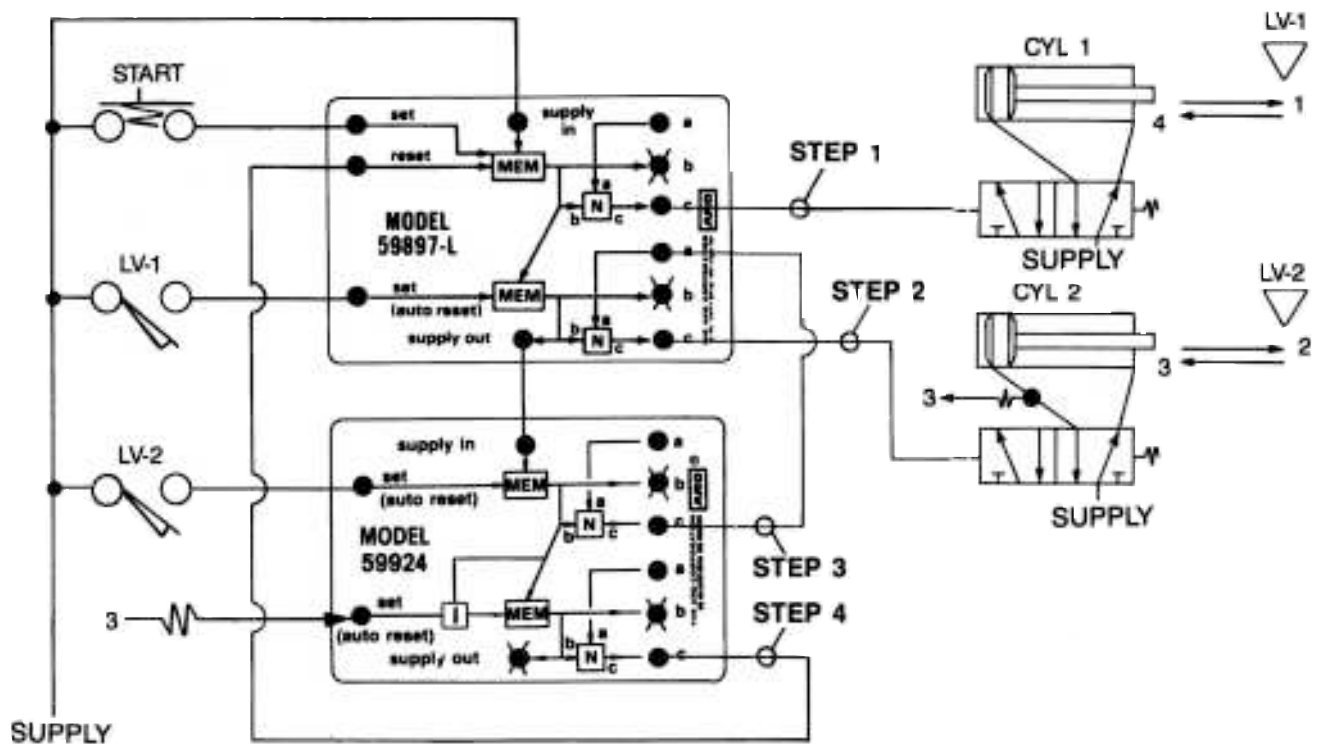

Description

This circuit is identical to the one shown in Illustration 5 except this circuit uses input signals and inhibitor function, rather than time delays, to start each step. The input signals come from limit valves that are mounted to detect the movement of each cylinder.

Connections

This circuit uses a 59897 and a 59924 Flex-6 unit. The output signals, the start signal and the supply are identical to those in Illustration 5. Three limit valves are mounted on the machine to detect the various cylinder positions. These positions are shown as triangles to the right of the cylinders. The same limit valves are shown again to the left of the Flex-6 circuit. They are connected to the Flex-6 circuit as follows:

- LV-1 to the set port of Step 2
- LV-2 to the set port of Step 3
- Signal 3 to the set port of Step 4

Function

1. At rest both cylinders are retracted.
2. When the operator actuates the start push button step 1 output goes on and cylinder 1 extends.
3. Cylinder 1 actuates limit valve one when fully extended. Limit valve one signals step 2 and step 2 output extends cylinder 2.
4. Cylinder 2 extends actuating limit valve 2 when it is fully extended. Limit valve 2 signals step 3 and step 3 output goes on. Step 3 output is connected to the "a" port of step 2. This removes the step 2 output and cylinder 2 retracts.
5. Cylinder 2 releases limit valve 2 then it retracts. When cylinder #2 is retracted, the pressure in line from valve to cylinder #2 drops to 0 PSI, ("A" port of inhibitor) and output 4 comes on. Step 4 output resets the circuit and cylinder 1 retracts.

Illustration 7

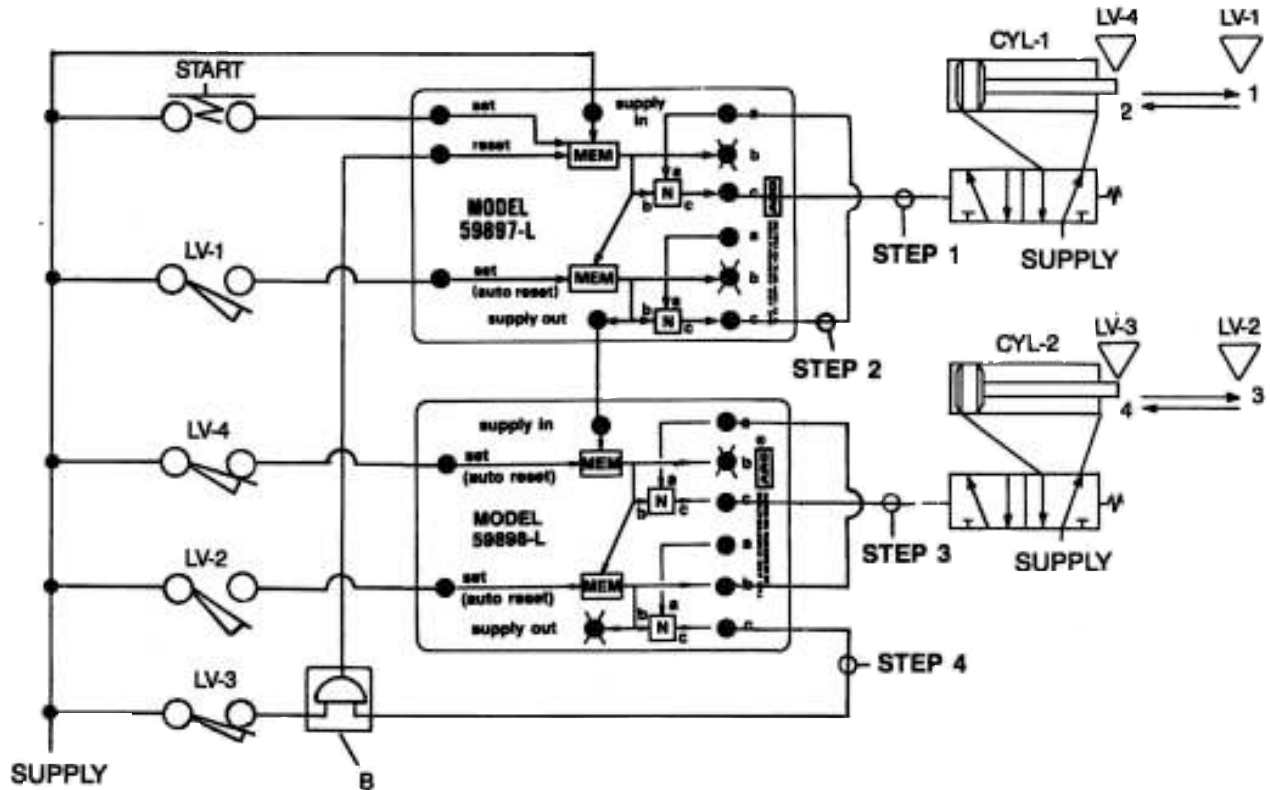

Description

This is the same sequence as shown in Illustration 4 except that limit valves are used to signal the start of each step. Two options (A & B) have also been added to the circuit.

- A. Option A cancels step 3 output and retracts cylinder 2 when output 4 comes on.
- B. Option B resets the circuit only after cylinder 2 is fully retracted.

Notes

The output connections and the input connections were changed from Illustration 6 to accomplish this sequence. Limit valve 4 was added so that each position of each cylinder could be detected. Step 5 is accomplished by “anding” step 4 output and the final limit valve input (LV-3). Using a 59913 in line “and” function. This could also be done by a series connection through limit valve 3.

This option is often used when each step of the sequence must be monitored closely. Example: continuous operating circuits.

Function

1. Operator actuates start push button. Cylinder 1 extends.
2. Cylinder 1 releases limit valve 4 and actuates limit valve 1. Step 2 output goes on retracting cylinder 1.
3. Cylinder 1 releases limit valve 1 and actuates limit valve 4. Step 3 output goes on extending cylinder 2.
4. Cylinder 2 releases limit valve 3 and actuates limit valve 2. Step 4 output goes on retracting cylinder 2.
5. Cylinder 2 releases limit valve 2 and actuates limit valve 3. Circuit resets and is now ready for a new cycle.

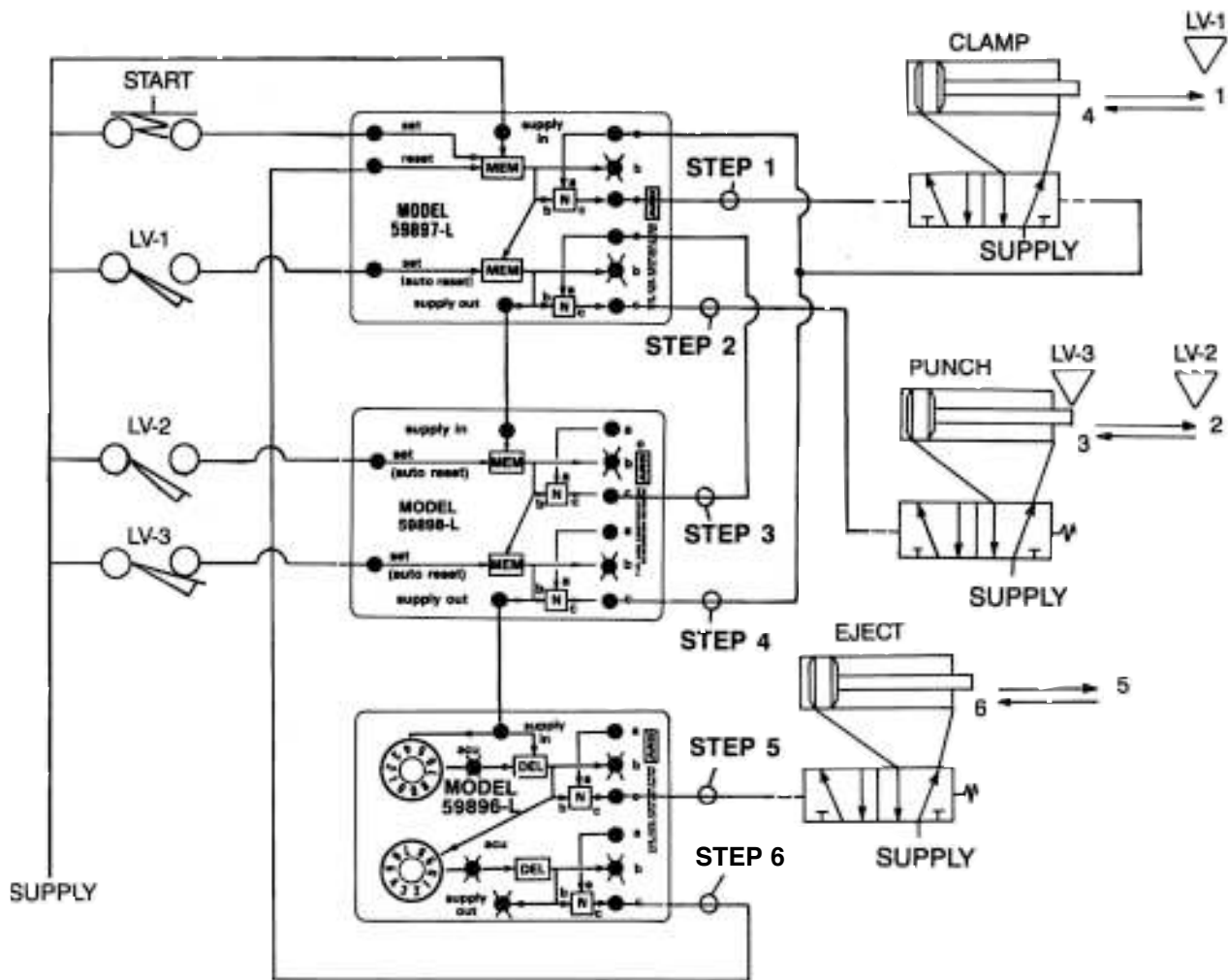
Illustration 8**Description**

Here is a six step sequence involving three cylinders. The sequence is as follows:

1. Operator actuates start push button. Clamp cylinder extends.
2. Clamp cylinder actuates limit valve 1. Punch cylinder extends.
3. Punch cylinder releases limit valve 3 and actuates limit valve 2. Punch valve retracts.
4. Punch cylinder releases limit valve 2 and actuates limit valve 3. Clamp cylinder retracts. Time delay 1 starts.
5. Time delay 1 times out. Eject cylinder extends, time delay 2 starts.
6. Time delay 2 times out. Eject cylinder is retracted and circuit is reset.

Variations

1. Both the 59898 (double input) and the 59896 (double timer) units are used in the same circuit.
2. This circuit also includes a double pilot valve on the clamp cylinder. Notice that the return pilot signal is simply tee'd from the signal that removes the step 1 output.

Illustration 9

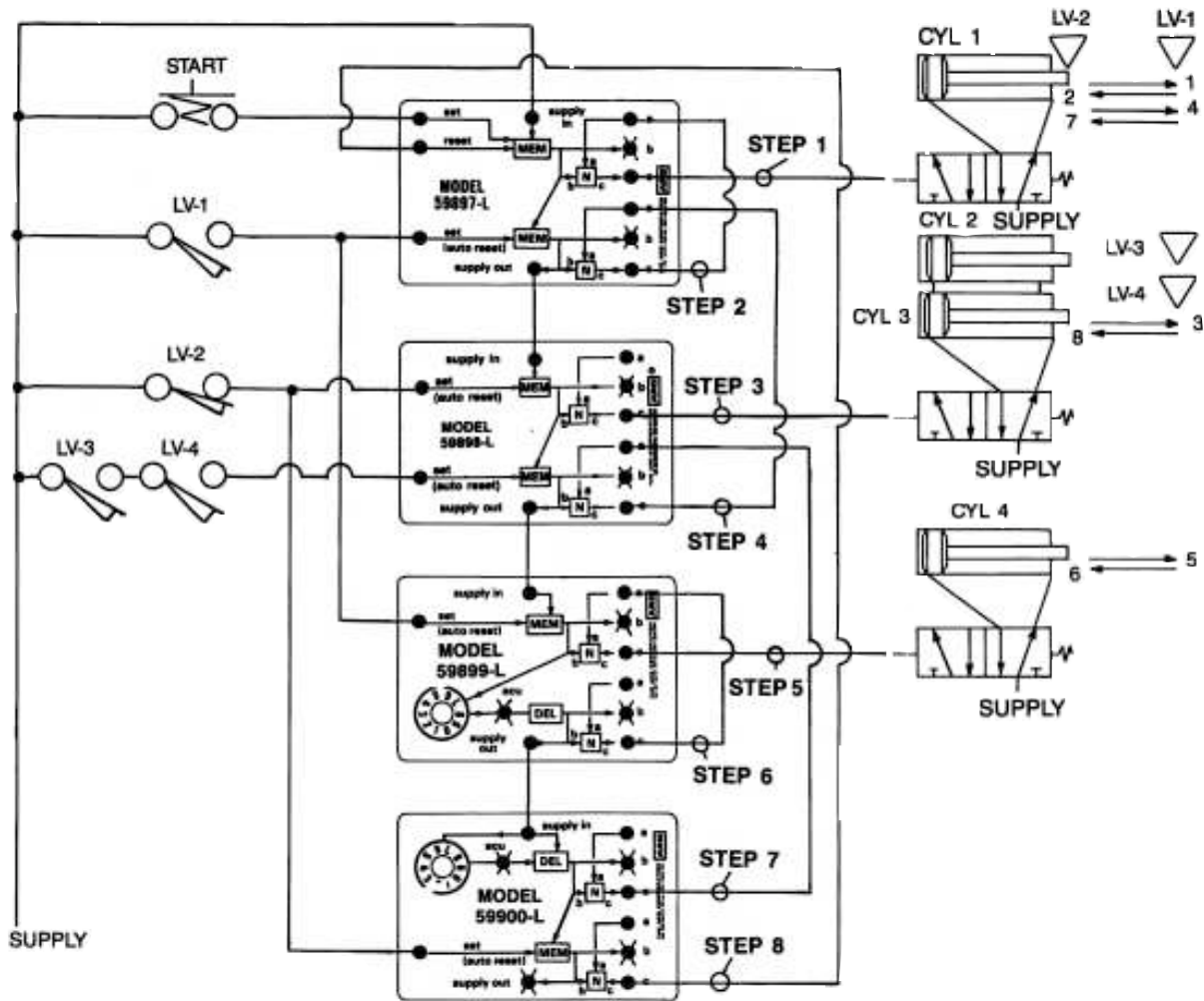

Description

The circuit in Illustration 9 shows several additional features of Flex-6 circuits.

1. Flex-6 circuits can include as many steps as necessary to complete the sequence. Additional Flex-6 blocks are simply added by connecting the “supply out” port of previous steps to the “supply in” port of new steps. Here we have 4 Flex-6 units providing 8 separate steps in the machine sequence.
2. We are also showing two new Flex-6 assemblies not previously shown. They are models 59899 and 59900 and are used in circuits such as this where some of the steps are controlled by timers and others by input signals.
3. Notice cylinders 2 and 3. When two cylinders work together their actions can be controlled by one step in the sequence. The only added provision here was to make sure both cylinder had fully extended before step 4 could take place. For this we provided limit valves 3 and 4. They can be connected in series (as shown) or “anded” together using a 59913 in line “and” function.
4. This drawing also shows a cylinder (cylinder 1) being extended and retracted twice in the sequence. First note how this is accomplished on the output side. Step one comes on and is later cancelled by step 2. Still later in the sequence step 4 output comes on, cancels step 2 and this allows step 1 to come back on. Finally step 7 comes on, cancels step 4, releasing step 2 and cancelling step 1. Notice also that limit valve 1 and 2 outputs can be used more than once in the same circuit. Simply tee their outputs and connect to the stage start ports indicated.

Other Six Element Assemblies

Four other six element assemblies are available. These units are sometimes used with Flex-6 circuits and in other cases provide a complete function in themselves.

Two-Hand Ant-Tie-Down Model 59191

The two-hand anti-tie-down is used to insure that both push buttons have been actuated before the cycle will start. When the anti-tie-down is used, both buttons must be actuated concurrently to create an output signal. Once either push button is released, the output signal goes off. Both push buttons must then be released and reactivated to start again.

The first drawing shows a two-hand anti-tie-down added to the start of a Flex-6 circuit.

The second drawing shows a more complex circuit which is used to insure that the operator hold both buttons until cylinder 1 is fully extended. Once cylinder 1 is extended and actuates limit valve 1, the push buttons can be released and the machine will continue its automatic cycle.

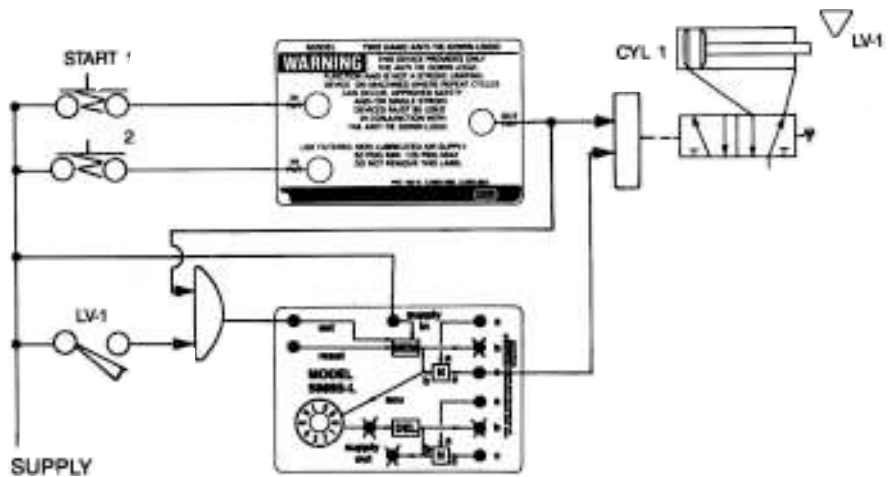
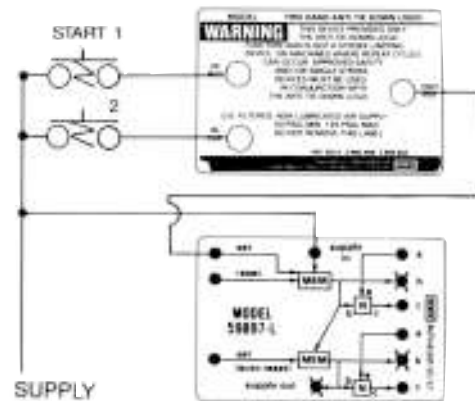

The Signal Standardizer Model 59860

The 59860 signal standardizer (or signal shaper) can be used to convert a signal of any duration to outputs of a predetermined time period.

When the start signal is received, the cylinder will extend for the period of time adjusted on the timer. Then the cylinder will retract. The start input signal can be shorter or longer than the output signal(s)* without affecting the timing function.

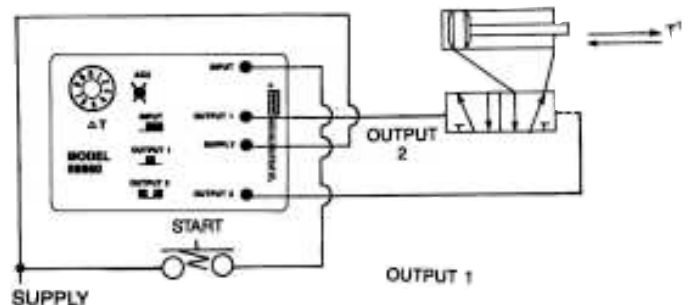

The Oscillator Circuit Model 59861

When a signal is received at the input of the oscillator circuit output T¹ will come on. After an adjustable period of time (adjustable at timer T¹) output T¹ will go off and output T² will go on.* After another adjustable period of time (adjustable at T²) output will go off and output T¹ will go on. This will continue as long as the input remains on.

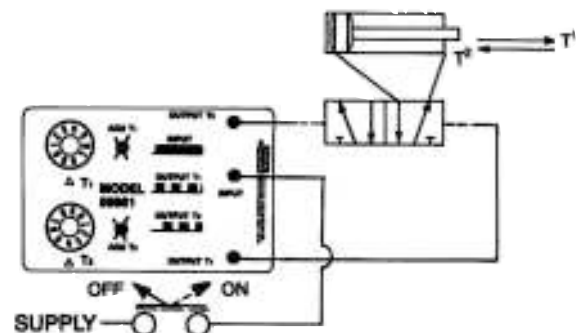

* Outputs not used can be plugged. Small cylinders can be ported directly to these outputs.

Cycle Repeat Circuit

Cycle Repeat Circuit Model 59919-1

This circuit is designed to replace the 59003-099 cycle repeat circuit.

The cycle repeat circuit shown can be added to any Flex-6 circuit so that it will recycle continuously. The circuit contained in this assembly is shown at the right.

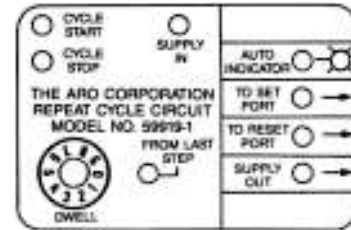

1. The cycle repeat circuit provides for:
 - A. Continuous recycling of a control circuit, started by a momentary start signal.
 - B. end of cycle stop – momentary input.
 - C. An adjustable dwell between cycles.
 - D. Single cycle operation.
 - E. Emergency stop.

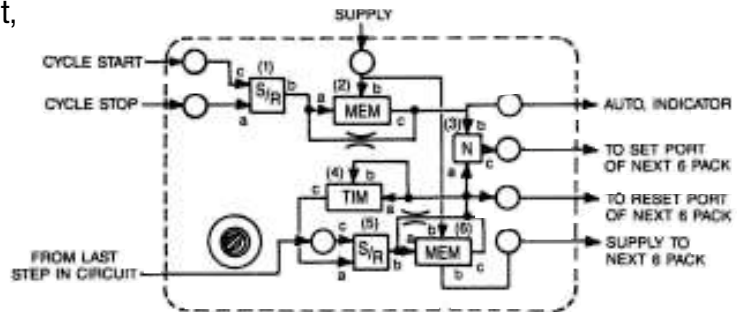

The illustration at right shows a cycle repeat circuit connected in its simplest form. Actuation of the start push button starts the circuit to run in an auto-recycle mode. When the cycle stop push button is actuated the circuit will complete that cycle and will not start the next cycle. If you want the cycle to stop immediately, add the connection shown by the dotted line.

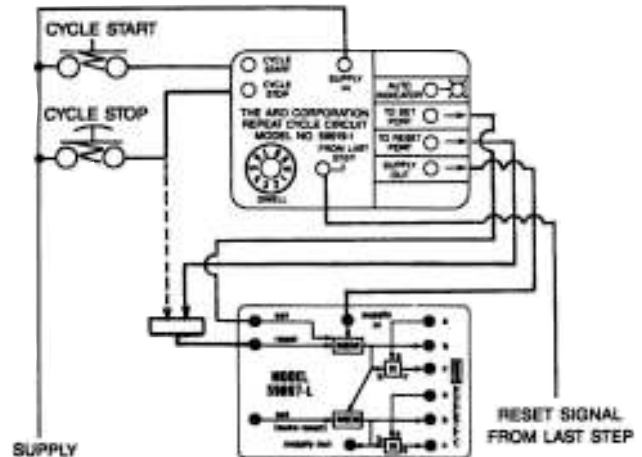

The illustration at right shows a more complex application of the cycle repeat circuit. Here we have provisions for either single cycle or automatic cycling and an auto cycle indicator. The circuit can be stopped either at the end of the cycle (with the auto cycle stop push button) or immediately (with the emergency stop button).

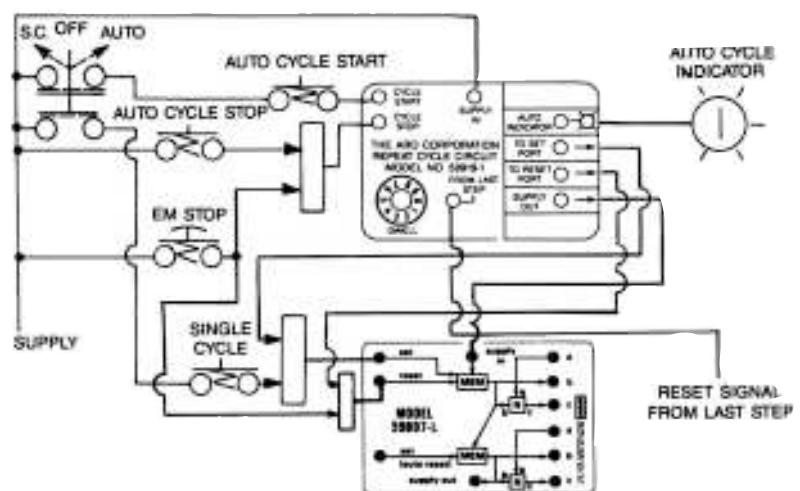

Features

Individual Elements

59010 "OR" Element

59023 "OR" Element on 1/8" Base

- Combines two air signals so either can produce an output.
- Output port C is pressurized when either input port A or B is pressurized "on".

Dimensions: 1 1/4" sq. x 1" (31.8mm sq. x 25.4mm)

Response Times: Input to Output Milliseconds

"A" on to "C" on	7.5
"B" on to "C" on	7

Truth table

A	B	C
1	0	1
0	1	1
1	1	1
0	0	0



59010

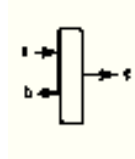

59111 "AND" Element

59124 "AND" Element on 1/8" Base

- Combines two signals so both must be on to create an output.
- Output port C is pressurized only when both inputs A & B are pressurized "on".
- Can be used with timer elements to produce time-delay functions.
- Shifting is snap-action when input at "A" port increases to 70% of pressure at "B" port. Return when "A" decreases to 40% of "B".

Dimensions: 1 1/4" Sq. x 1 21/32" (31.8mm sq. x 42.1mm)

Response Times: Input to Output Milliseconds

"A" on to "C" on	8
"A" off to "C" off	9.5

Truth table

A	B	C
1	0	0
0	1	0
1	1	1
0	0	0



59111

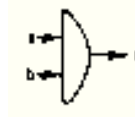

59112 "NOT" Element

59125 "NOT" Element on 1/8" Base

- Combines two signals so that one ("B") must be on, and the other ("A") must be off to create an output.
- Output C is pressurized only when input B is pressurized and input A is off.
- Shifting is snap-action when input at "A" increases to 70% of pressure at "B". Return when "A" decreases to 40% of "B".

Dimensions: 1 1/4" Sq. x 1 21/32" (31.8mm sq. x 42.1mm)

Response Times: Input to Output Milliseconds

"A" on to "C" off	8.5
"A" off to "C" on	9

Truth table

A	B	C
1	0	0
0	1	1
1	1	0
0	0	0



59112

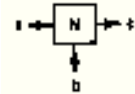

59800 Inhibitor Element

59912 Inhibitor Assembly on 1/8" Base

- Functions as NOT element except pressure at A must drop below 5% of supply before element will reset, regaining output at C.
- Useful in detecting air cylinder motions where limit valves cannot be applied.

Response Times: Input to Output Milliseconds

A on to C off	15
A off to C on	25



59800

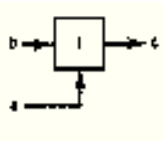

59181 Set-Reset (S-R) Gate and 59113 Memory Models

59185 Set-Reset (S-R) Gate and Memory Assembly on 1/8" Base

- The elements work together to perform a memory function.
- With constant supply at B of MEM and B of S-R connected to A of MEM, a momentary pressure signal at C of S-R will cause C of MEM to pressurize. C of MEM will remain pressurized until a pressure signal to A of S-R is received.
- The MEMORY is pneumatically retained. If supply is removed (B MEM off), output C will go off & remain off until a new set signal is received.
- The reset signal ("A" of S-R) is snap-action function and can be connected to a TIMER element to create a delayed reset function.

Dimensions: 1 1/4" sq. x 1 21/32" (31.8mm x 42.1mm)

Minimum Time: Signal Milliseconds

To SET	17
To RESET	19



59181



59113

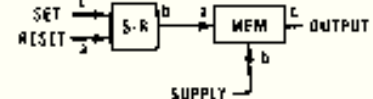

Features

Flip-Flop

59892 "FLIP FLOP" Model

- A memory type element, Flip-Flop converts momentary signals received at the set and reset ports into maintained corresponding outputs.
- A set signal at A shifts the Flip-Flop to C port on and resets D to off. A reset signal at F shifts the Flip-Flop to D on and C off.
- If set or reset signals are maintained, later signals of equal pressure to the opposite input will not alter the output condition.
- The Flip-Flop has six ports and requires two element spaces.

A Set Input D Reset Output
 B Supply E Supply
 C Set Output F Reset Input

- 59892 has two top ports (10-32) for C & D outputs.
- Shift pressure is 50% of supply pressure.
- Dimensions: 2 1/2" x 1 7/32" (63.5mm x 36.5mm)

Approximate Response Time

Input to Output	Milliseconds
A on to C on	11
F on to D on	11



59892

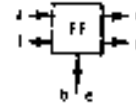

Delay Elements & Assemblies

DELAY ELEMENTS

- Combine an AND and a TIMER function.
- With supply present at B, output will be pressurized (C on) a predetermined amount of time after input A is pressurized. Time can be fixed or adjustable.
- Reset time (time signal at "A" must be off between cycles) is 100 milliseconds.
- Timing ranges for individual elements cannot be increased. For longer delays, a base mounted assembly is needed.

DELAY TIMING IN FUNCTIONS

1. With the input off, the output will also be off.
2. The timing function starts when the input goes on.
3. When the timing is complete, the output goes on.
4. Output goes off immediately when input is removed.

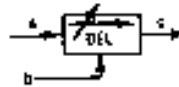

Screwdriver Adjustable Delay Units

- ±4% timing accuracy.

Individual Element

59121 Timing Range: .08 to 4.5 seconds

Base Mounted Elements (1/8" Base)

59158 Timing Range: .08 to 4.5 seconds

59879 Timing Range: 4.1 to 24.5 seconds



59121



59158



59156

Dial Adjustable Delay Units

- ±4% timing accuracy.

Individual Element

59156 Timing Range .08 to 4.5 seconds

Base Mounted Elements (1/8" Base)

59160 Timing Range: .08 to 4.5 seconds



59166-4

59166-4 Fixed Delays

- Not adjustable. Order model for desired time.
- Dimensions: 1 1/4" sq x 2 3/4" (31.8mm sq. x 69.9mm)

Model	Milliseconds
59166-4	445 ± 40

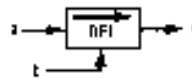

Dimensions for Base Assemblies are on page 109.

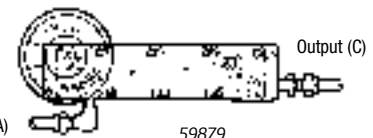

59879

Features

Pulse Elements & Assemblies

PULSE ELEMENTS

- Combine a NOT and a TIMER function.
- These perform TIMING-IN inverted or PULSE functions, depending on connections to supply port B.

For TIMING-IN INVERTED function: With port B pressurized, C port remains on until port A is pressurized. When A is pressurized, C will go OFF after a predetermined amount of time.

PULSE function: When A & B are connected together, output C is normally off. If inputs are applied to A & B, output C goes on. C remains on for timer period, then goes off and remains off until inputs are removed and reapplied. Reset time is 100 milliseconds. The predetermined amount of time can be fixed or adjustable.

1. With input off, the output will also be off.
2. Output goes on & timing starts when input comes on.
3. When timing is completed, output goes off.
4. Remove & reapply input to get second output.

NOTE: Input must be longer than output for full times signal. If not possible, see momentary timers.

Screw Adjustable Pulse Timers

- $\pm 4\%$ timing accuracy.

Individual Element

59120 Timing Range: .08 to 4.5 seconds

Base Mounted Elements (1/8" Base)

59157 Timing Range: .08 to 4.5 seconds

59874 Timing Range: 3.0 to 14.5 seconds

59881 Timing Range: .20 to 24.5 seconds

Dial Adjustable Pulse Timers

Individual Element

59155 Timing Range: .08 to 4.5 seconds

Base Mounted Elements (1/8" Base)

59159 Timing Range: .08 to 4.5 seconds

59875 Timing Range: 3.0 to 14.5 seconds

59882 Timing range of 4.6 to 24.5 seconds

59165-4 Fixed Pulse

- Not adjustable, order model for time desired; $\pm 10\%$ timing accuracy.

Dimensions: 1 1/4" sq x 2 3/4" (31.8mm sq. x 69.9mm)

Model	Milliseconds
59165-4	445 \pm 40

59114 Differentiator

- A non-adjustable pulse element.
- With A blocked, signal at B will produce an output at C of 80 to 130 milliseconds. Output can be lengthened by connecting a 59117 Accumulator to port A.
- Reset time is 110 milliseconds.

Dimensions: 1 1/4" sq. x 1 3/4" (31.8mm sq. x 44.5mm)

Dimensions for Base Assemblies are on page 109



59120



59157



59155



59165-4



59874 / 59875

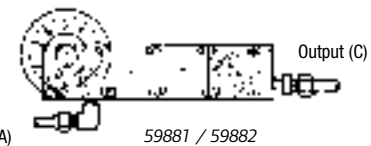

59881 / 59882



59114

Features

Timer Elements

TIMERS are used in conjunction with snap-acting 59111 AND, 59112 NOT, 59181 S-R GATE or 59800 INHIBITOR to perform special functions not offered in one complete element.

- Overall height of circuit board can be reduced by using these combinations rather than elements which combine these functions.
- Timing periods can exceed 4.5 seconds when using with 59117 Accumulators.
- Time can be fixed or adjustable, depending on element selected.

59115 Screw Adjustable Timer

- Connected to A of snap-acting AND or NOT element, these timing ranges can be accomplished.

Dimensions: 1 1/4" sq. x 2 7/64" (31.8mm sq. x 53.6mm)

Timer	Number of 59117 Accumulators	Timing Range ±4% Seconds
59115	0	.08 to 4.5
59115	1	.14 to 14.5
59115	2	.20 to 24.5
59115	3	.26 to 34.5
59115	4	.32 to 44.5

59116 Dial Adjustable Timer

- Connected to A of snap-acting element, these timing ranges can be accomplished.

Dimensions: 1 1/4" sq. x 3 5/16" (31.8mm sq. x 84.1mm)

Timer	Number of 59117 Accumulators	Timing Range ±4% Seconds
59116	0	1.4 to 4.5
59116	1	3.0 to 14.5
59116	2	4.6 to 24.5
59116	3	6.2 to 34.5
59116	4	7.8 to 44.5

Accumulator

59117 Accumulator

- Used with timing elements to extend timing range. C port is connected to output of timing element. Volume is approximately 1 cu. in. (16.4 cm³).

Dimensions: 1 1/4" sq. x 2 1/16" (31.8mm sq. x 52.4mm)

Fixed Orifice plates and Port Plug

- Can be mounted in inlet or outlet ports of any element to reduce flow and/or increase response time.
- Fits into O-Ring cavity of element base.
- Plug is used to isolate port from channel connection.

Model	Orifice Size Inches (mm)
59671-1	.0135 (.343)
59671-2	.0180 (.475)
59671-3	.0225 (.572)
59671-4	.0260 (.660)
59718	Plug



59115



59116



59117

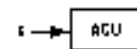

59671-X

Features

NOT Amplifier

59176 NOT Amplifier

- The element converts low pressure signals such as those used in liquid level sensing, to high pressure signals compatible with other APLC elements.
- Performs NOT function with exception when C output is greater than input of A₁.
- Input A & B ports must be interconnected externally of element.
- Output C is on only when low pressure at A₁ is off. C output equals pressure at A & B.
- Shift pressure depends on element ordered and adjusted setting.
- Sensitivity adjustment screw allows adjustment of shift point within adjustable range.

Dimensions: 1 1/4" sq. x 3" (31.8mm sq. x 76.2mm)

Individual Element	Approximate Response Time Input to Output	Milliseconds	Adjustable A1 Pressure Range PSIG when a & b = 50 PSIG (3.4bar)
59176-1	A ₁ on to C off	10	.24 to 1.5 (0.11 to .07)
59176-2	A ₁ off to C on	10	1.5 to 15 (0.7 to 1.0)

Element on Base Assys.	Approximate Response Time Input to Output	Milliseconds	Adjustable A1 Pressure Range PSIG when a & b = 50 PSIG (3.4bar)
59162-2	A ₁ off to C on	10	1.5 to 15 (0.7 to 1.0)

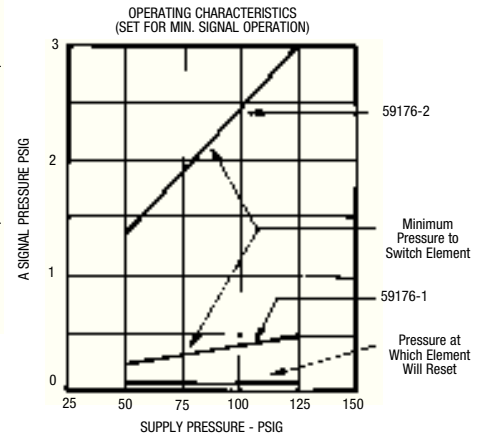
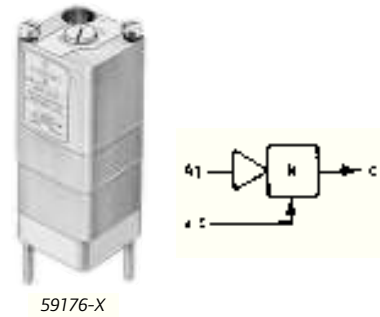

AND Amplifier

59175 "AND" Amplifier

- The amplifier converts low pressure signals such as those used in liquid level sensing, to high pressure signals compatible with other APLC elements.
- Performs AND function except when output at C is greater than input A₁.
- Inputs A & B must be interconnected externally of the element.
- Output C is on only when A₁ receives a low pressure signal and inputs A & B are pressurized. Output at C equals pressure at inputs A & B.
- Shift pressure depends on element ordered and adjusted setting.
- Sensitivity adjustment screw allows adjustment of shift point within adjustable range.

Dimensions: 1/4" sq. x 3" (31.8mm sq. x 76.2mm)

Individual Element	Approximate Response Time Input to Output	Milliseconds	Adjustable A1 Pressure Range PSIG when a & b = 50 PSIG (3.4bar)
59175-1	A ₁ on to C on	10	.24 to 1.5 (0.11 to .07)
59175-2	A ₁ off to C off	10	1.5 to 15 (0.7 to 1.0)

Element on Base Assys.	Approximate Response Time Input to Output	Milliseconds	Adjustable A1 Pressure Range PSIG when a & b = 50 PSIG (3.4bar)
59161-1	A ₁ on to C on	10	.24 to 1.5 (0.11 to .07)
59161-2	A ₁ off to C off	10	1.5 to 15 (0.7 to 1.0)

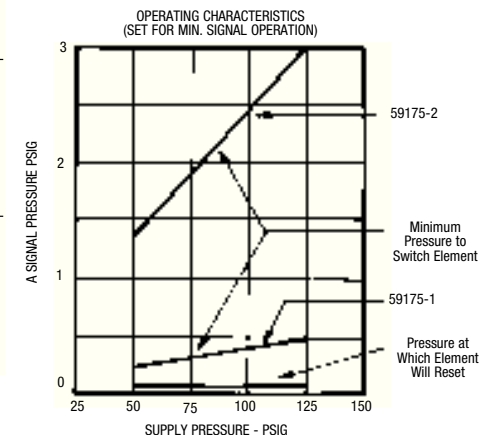
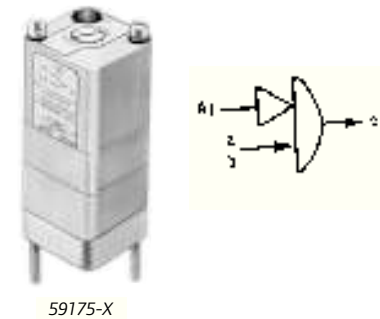

Dimensions for Base Assemblies are on page 109.

Features

Special Purpose Elements

59089 Two to Three-Way Converter

- Used to convert a two-way (bleed signal) to a three-way (pressure-exhaust) signal.
- With supply B pressurized, C will be pressurized if A is not blocked. When A port is blocked, C will go off.

Dimensions: 1 1/4" sq. x 1 21/23" (31.8mm sq. x 42.1mm)

Approximate Response Time

Input to Output	With 6" (152mm) 5/32" (4mm) Tubing to A---Milliseconds	Add Milliseconds for each Foot more Tubing
A open to C on	14	5.5
A blocked to C off	70	32.5
Start up B to C pulse	90	33.5



59089

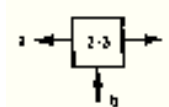

59890 Vibrator Element

59866 Vibrator on 1/8" Base

- With input B on, C output will come on and go off in a constant timed pattern until the input is removed.
- The on and off times are not independently adjustable.
- Adjustment timing range: .08 to 4.5 seconds. Output off equals 80% of on setting.
- C port must also be connected to the A input port on element.

Dimensions: 1 1/4" sq x 2 3/4" (31.8mm sq. x 69.9mm)



59890

59891 Air to Electric Interface Device

- Normally open, single throw, single pole pressure switch.
- Mount to top of C port of standard element.

Dimensions: 1 7/16" dia. x 2 1/4" Wire is 22AWG

Model	Supply	Output	Connections	Response Time
59891	30-150 PSI	5 Amps Max	1/8-27 NPT	On - 1 ms Off - 4 ms



59891

59915-XX Electric to Air Interface Device

- Normally non-passing, three-way, single solenoid actuated valve.
- With B pressurized and the coil energized, an air output occurs at C port.
- When de-energized, B is blocked and C exhausted.
- Must be mounted on perimeter of circuit board.

Model	Supply	Output	Connections	Coil Replacement
59915-38	12V DC/24 VAC	Air Signal	A blocked	116218-38
59915-39	24V DC	30-150PSI	B supply	116218-39
59915-33	120V AC	(2-10 bar)	C output	116218-33



59915-XX

Porting Block

59109 Porting Block

- Provides three instant tube fittings. One each to A, B or C ports of elements.
- One porting block required for each element.

Dimensions for Base Assemblies are on page 109.



59109

Features

Mounting Equipment

59200-XX Base Plate

- Contains two mounting holes and three porting holes for each element.
- Surface is metallic grit etched and plated to resist corrosion.

59595-88 Module Gasket

- Corresponding circuit pattern of layout sheet is printed on module. Air channels are then cut into gasket for air passage.

59201-XX Cover Plate

- Used in conjunction with 59200 base plate to retain 59595 module.
- Contains only the mounting holes required by elements.
- Surface is metallic grit etched and plated to resist corrosion.

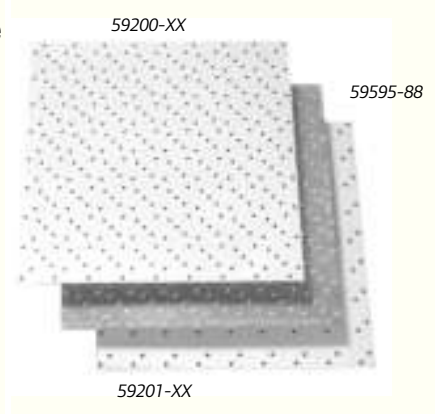

Model:	Dimensions in Inches (Millimeters)	Element Coverage
Base Plate		
59200-24	5/64 x 3 21/64 x 5 53/64 (2 x 85 x 148)	2 x 4
59200-44	5/64 x 5 53/64 x 5 53/64 (2 x 148 x 148)	4 x 4
59200-66	5/64 x 8 21/64 x 8 21/64 (2 x 212 x 212)	6 x 6
59200-88	5/64 x 10 45/64 x 10 45/64 (2 x 272 x 272)	8 x 8
Module Gasket		
59595-88	1/16 x 10 45/64 x 10 45/64 (2 x 272 x 272)	8 x 8
Cover Plate		
59201-24	5/32 x 3 21/64 x 5 53/64 (4 x 85 x 148)	2 x 4
59201-44	5/32 x 5 53/64 x 5 53/64 (4 x 148 x 148)	4 x 4
59201-66	5/32 x 8 21/64 x 8 21/64 (4 x 212 x 212)	6 x 6
59201-88	5/32 x 10 45/64 x 10 45/64 (4 x 272 x 272)	8 x 8

Base Assembly Method

- Simple logic functions requiring up to four elements can be mounted using the function base assembly method.
- Interconnections between elements are made in a module below the elements. External connections are made via the 1/8" NPTF ports on the porting blocks.



Model:	Base Assembly	# of Ports
59387	1-Element	3
59061	2-Elements	6
59062	3-Elements	8
59063	4-Elements	10

Components
 Base, Washer & nuts.
 Base, Cover plate,
 module, pipe plugs,
 nuts and washers.



58023 Split Bit
 1/4" Hex Shank Bit used to build
 function base assemblies

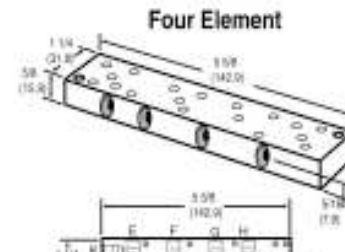
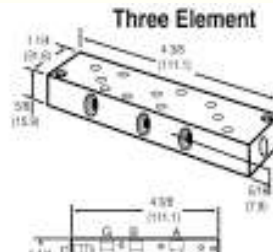
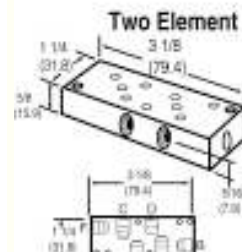
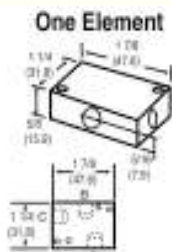

Features

Multiple Snap Indicator

- Bright sleeve within indicator extends to indicate pressurized condition. Sleeve retracts when pressure is removed.
 - Snap-in design for installation into 11/16" (17.5mm) hole.
- Pressure Range: 30-150 PSI (2.1-10.4 bar)

59812-1 Red Indicator 1/8" Ports

59812-3 Green Indicator 1/8" Ports

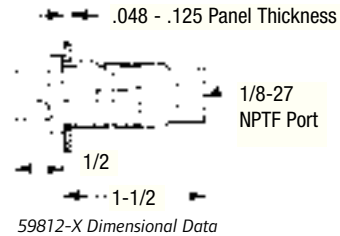

Element Test Indicators

- Used to indicate an output pressure signal from an element.
 - Thread into test port of "OR", "AND" or "MEM" elements.
- 24130** Press to test indicator.

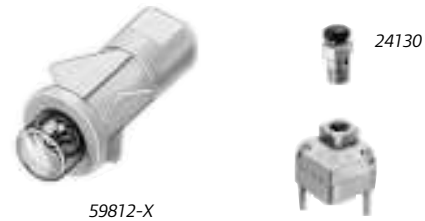

Panel Mounted Miniature Control Valves

- Uses basic 200 Series 3-way valves.
- Valves are available with push button or rocker type selectors.
- Order legend sheets separately.

3-Way Control Valve Assembly

1/8" Ports Models	Tube Fittings Models	Actuation Type	Port Designation
59803	59803-1	Pushbutton (Momentary)	1-in, Non-Passing
59804	59804-1	Rocker (Maintained)	3-in, Passing 2-Output

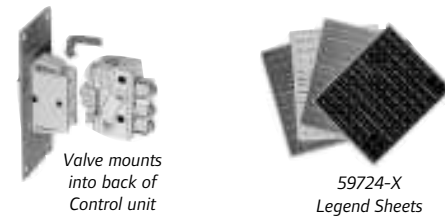

59724-X Legend Sheets

Self-adhesive. They fit into recesses of valves and indicators.

Model	Color
59724-1	Black
59724-2	White
59724-3	Green
59724-4	Red

Dimensions and Mounting Information

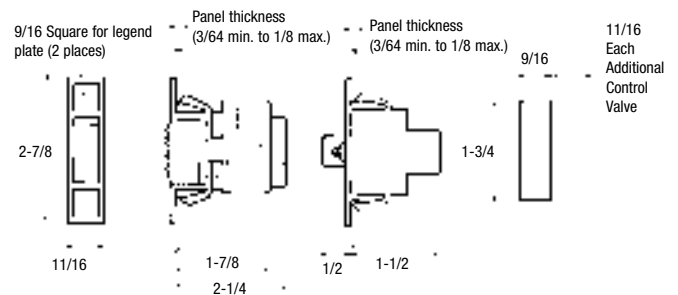

Features

- Can be plumbed normally passing, non-passing, selector or any two-way function.
- Eight button styles. Oil tight, all metal construction.
- Fifteen legends available.
- Uses basic 200 Series 3-way valves.
- Can activate one or two control valves.
- **Order Valve Kits, Operators, and Legend Plates separately.**
- Kits shipped unassembled.

Push Button Assembly

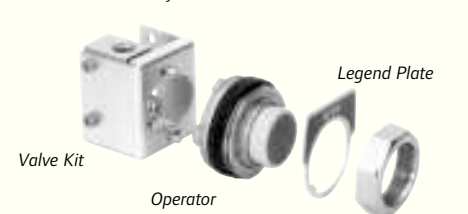

Performance Specifications

Pressure Range:

30 to 150 PSIG (2.1 to 10.4 bar)

Temperature Range:

32 to 160 F (0 to 71 C)

Flow & Cv Factor:

1/8" Ports

7.5 SCFM

Cv = .195

5/32" (4mm) Tube Fittings

4.0 SCFM

Cv = .104

Valve Kits Ordering Menu

1/8" Ports	Tube Fittings	# of Valves
59064	59064-1	1
59065	59065-1	2

Push Button Operators

Model	Description
59067-10	1 3/8" (35mm) Red Button
59067-11*	Without Guard
59067-12*	Extended Guard
59067-13*	Full Guard
59067-15	1 3/8" (35mm) Red Button Push/Pull Action
59067-16	2-1/4" (57mm) Red Button
59067-17	2-1/4" (57mm) Green Button
59067-18	Momentary, universal, dual function push button

Push Button

Model
59068-14
59068-15
59068-30
59068-33
59068-34
59068-42

Legend Plates

Plate Marking
Emergency Stop
Start
Blank
Down
Up
Reset



*Inserts included:

(Yellow, White, Green

Orange, Black, Blue, Red)

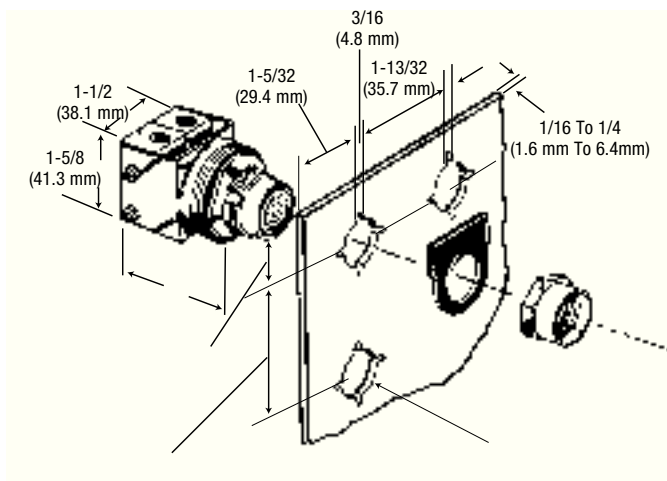

Features

- Can be plumbed normally passing, non-passing, selector or any two-way function.
- Eight button styles. Oil tight, all metal construction.
- Fifteen legends available.
- Uses basic 200 Series 3-way valves.
- Can activate one or two control valves.
- **Order Valve Kits, Operators, and Legend Plates separately.**
- Kits shipped unassembled.

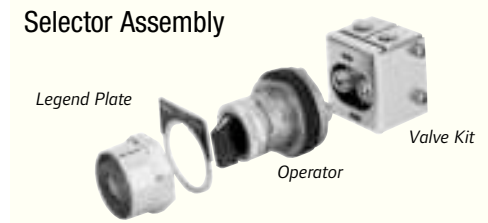

Performance Specifications

Pressure Range:

30 to 150 PSIG (2.1 to 10.4 bar)

Temperature Range:

32 to 160 F (0 to 71 C)

Flow & Cv Factor:

1/8" Ports

7.5 SCFM

Cv = .195

5/32" (4mm) Tube Fittings

4.0 SCFM

Cv = .104

Valve Kits Ordering Menu

1/8" Ports	Tube Fittings	# of Valves
59064	59064-1	1
59065	59065-1	2

Selector Operators

Model	Description
2-Position Maintained	
59066-10	Standard Knob
59066-11	Gloved Hand Knob
59066-133	Key Operated
3-Position Maintained	
59066-16	Standard Knob
59066-17	Gloved Hand Knob
59066-191	Key Operated

3-Position Spring Return

59066-20	Standard Knob
59066-21	Gloved Hand Knob

Selector Legend Plates

Model	Plate Marking
2 Position	
59068-22	Off-On
59068-24	Open-Close
59068-30	Blank
59068-62	Forward-Reverse
59066-16	Standard Knob
59068-66	On-Off
59068-70	Up-Down
3 Position	
59068-26	Forward-Off-Reverse
59068-27	Auto-Off-Hand
59068-28	Open-Off-Close
59068-30	Blank
59068-77	Man-Off-Auto



Features

Control Enclosures

58027

- Accepts single push button, selector or palm button valves.
 - Standard 1/2" and 3/4" conduit knock-outs at top and bottom.
- Dimensions: 4 3/8" x 4 3/8" x 3 5/8" (111.1mm x 111.1mm x 82.1mm)



58027

59361

- Accepts four push button, selector or palm button valves.
 - Standard 1/2" and 3/4" conduit knock-outs at top and bottom.
 - Includes grommets, screws, washers and nuts for installation.
- Dimensions: 4 3/8" x 10" x 3 5/8" (111.1mm x 254mm x 82.1mm)

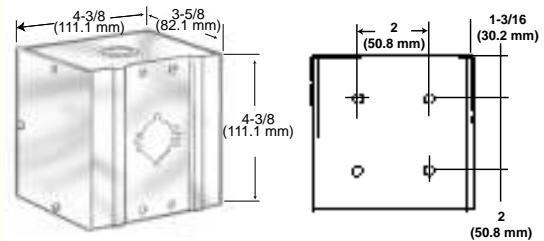

59792

- Accepts single push button, selector or palm button valves.
 - Standard 1/2" and 3/4" conduit knock-outs at top and bottom.
 - Additional space provided for circuitry.
- Dimensions: 4 3/8" x 10" x 3 5/8" (111.1mm x 254mm x 82.1mm)

59097-6 Hinged Mounting Plates

- Accepts 6 x 6 element circuit boards.
- Provides mounting and swing-out of circuit boards.
- Requires 5/8" (15.9mm) clearance for circuit boards, 2 3/8" (60mm) for back tubulation.

Circuit Bds	Elements	Dimensions
59097-6	6 x 6	9 1/2" x 10" (241 x 254mm)



59361

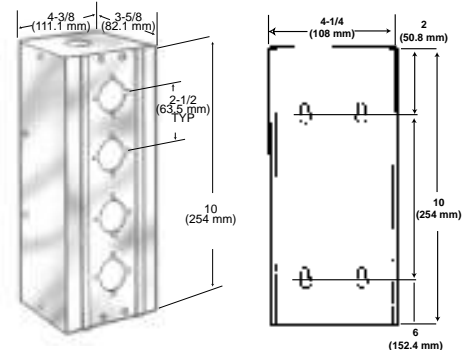

59792



59097-6

Features

Pneumatic Counters

Totalizing Counters/Manual Reset

59095-1 Knob Reset/Base Mount

- Counter advances one digit each time a pneumatic pulse is received.
- 600 counts/minute maximum.

59095-2 Dial Reset/Panel Mount

- Counter advances one digit each time a pneumatic pulse is received.
- 600 counts/minute maximum. Can also be base mounted.

Specifications

Operating Pressure: 30 to 150 PSIG (2 to 10 bar) **Operating Temperature:** 32° to 160°F (0° to 71°C)

Minimum Signal Duration: Pressure Signal 0.05 sec. **Ports:** 1/8" NPTF

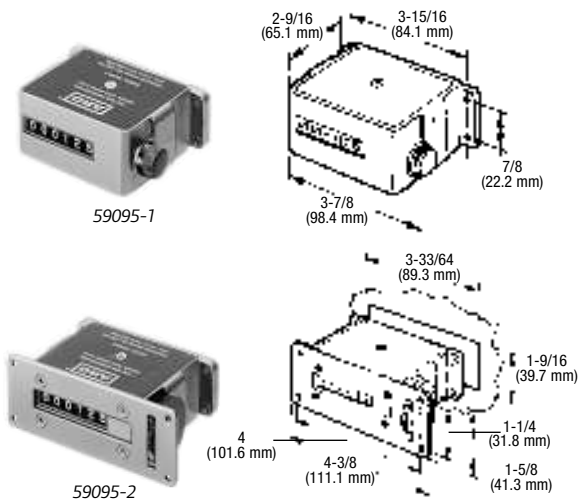

Totalizing Counter/Manual or Pressure Reset

59801 Panel Mount

- 6-digit readout. Records up to 1500 counts/minute
- Can be reset using reset button or pneumatic signal.

Specifications

Operating Pressure: 30 to 115 PSIG (2 to 8 bar) **Operating Temperature:** 32° to 140°F (0° to 60°C)

Minimum Signal Duration: Pressure Signal .008 sec. Exhaust Signal .010 sec. Reset Signal .150 sec. **Ports:** 5/32" (4mm) Tube Fittings

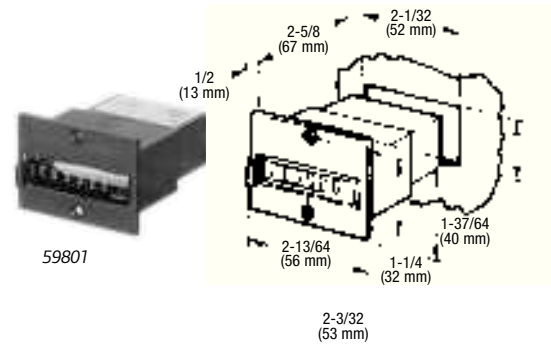

Predetermined Counter/Manual or Pressure Reset

59802 Panel Mount

- 5-digit readout.
- Each pneumatic pulse decreases predetermined number by one until zero is reached. An output signal is then provided.
- Counter is reset to predetermined number by the reset button or a pneumatic signal.

Specifications

Operating Pressure: 30 to 115 PSIG (2 to 8 bar) **Operating Temperature:** 32° to 140°F (0° to 60°C)

Minimum Signal Duration: Pressure Signal .008 sec. Exhaust Signal .012 sec. Reset Signal .180 sec. **Ports:** 5/32" (4mm) Tube Fittings

Port Designation:
P (3) Supply, A (4) Output,
Z (1) Count, Y (2) Reset.

Flow: 4.5 SCFM (2.1 dm³/s)

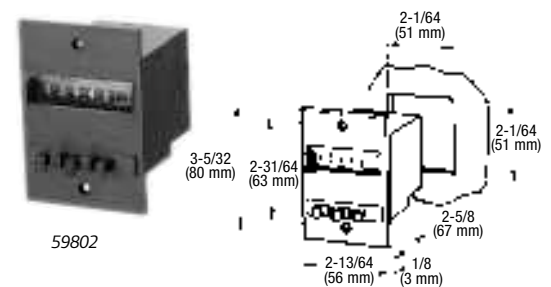

Liquid Level Sensor

- Sensors produce a pneumatic output signal as fluid levels in an unpressurized vessel rise or fall past predetermined levels. Will accurately sense almost any fluid.
- Supply pressure range: 30 to 150 psig. Range recommended for quickest response is 50 to 100 psig.
- When on, the output is the same pressure as that supplied to the air inlet. When off, the output is connected to atmosphere through an internal exhaust port. This insures a sharp on-off signal from the sensor.
- Units supplied with 25' of flexible 1/4" tubing.



59916-X

59916-1 High Level Sensor

- Provides an output signal when sensing tube is blocked by a liquid.

59916-2 Low Level Sensor

- Provides an output signal when sensing tube is not blocked by a liquid.

How to set-up your Liquid Level Sensor

Liquid level sensors are supplied with a 25' length of 1/4" diameter flexible nylon tubing. This tubing attaches to the sensing port (a 1/4" tubing bulk-head fitting located in the bottom of the panel near the regulator adjustment). This is a quick disconnect type fitting; simply push the tubing firmly into the fitting until it locks.

Next, cut the tubing to length and/or attach to the final sensing probe. Install the sensor probe with the open end pointing downward and located at or just below (0 to 2 1/2", depending on type of liquid and design of probe) the level where the operating signal should occur. In some cases, you may use the flexible tubing itself as the sensing probe. In other cases, you may want to use a length of pipe or rigid tubing as a final sensing probe so that it is easier to mount and adjust to the proper depth. The sensor probe will vary with the nature of the fluid being sensed. In all cases, it will need to be chemically and temperature compatible. For water fluids, the open end of the supplied tubing is adequate. For fluids of greater viscosity, you may want to increase the diameter of the opening for greater sensitivity.

Maintain Liquid Level

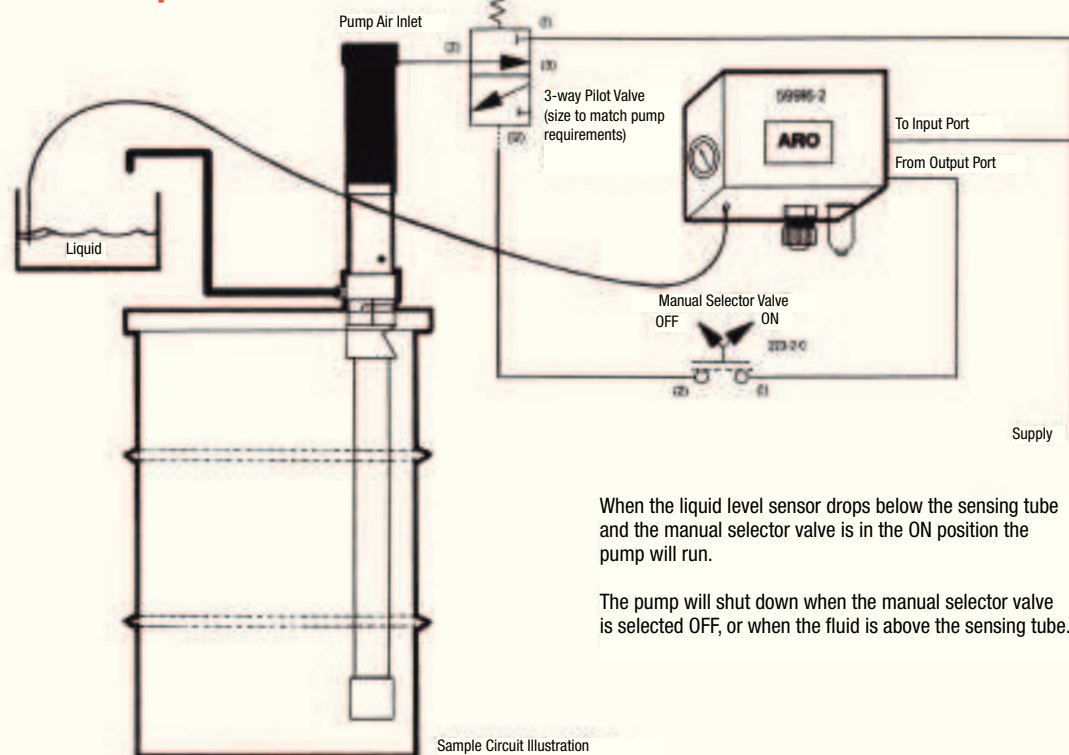

Features

Pneumatic Sensing Components

59807 Amplifier

- Designed to amplify low pressure signals from sensors.
- Actuates at signal pressures as low as one to four inches (249 to 995 Pa) of water.



59807

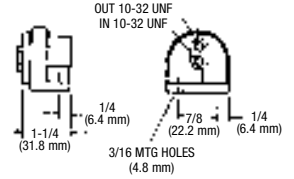
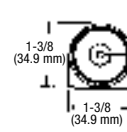

Tubing, Fittings & Connectors

Y-Connector	Tube Size
59482	5/32

Male Connector	Tube Size	NPT
59474-4	5/32	1/8
59474-56	1/4	1/8
59474-156	1/4	1/4
59474-256	1/4	3/8



Tubing (100' rolls)	Tube Size
59690-4	5/32



Male Elbow	Tube Size	NPT
59756-103	5/32	#10-32
59756-4	5/32	1/8
59756-56	1/4	1/8
59756-156	1/4	1/4



Male Branch Tee	Tube Size	NPT
59757-4	5/32	1/8
59757-56	1/4	1/8
59757-156	1/4	1/4



Plug	Tube Size
59463-4	5/32
59463-56	1/4



Union	Tube Size
59759-4	5/32
59759-56	1/4



Union Elbow	Tube Size
59760-4	5/32
59760-56	1/4



Union Tee	Tube Size
59761-4	5/32
59761-56	1/4



Union Bulkhead	Tube Size
59762-4	5/32
59762-56	1/4



Expander Tube	Male Tube Size	NPT
59765-4	5/32	1/4



Reducer Tube	Male Tube Size	NPT
59765-56	1/4	5/32

Maximum Working Pressure Vacuum to 250 PSI (17 bar)
 Temperature Range - +5°F to 160°F (-15°F to 71°C)
 Tubing Material: Nylon II

Flex-6 Accessories

59629 Adapter
 1/8" to 10-32 Thread



59634 Cross Junction
 10-32 Thread



5990X Push On Connector
 59905: 10-32 NPT x 1/16" Tube
 59906: 10-32 NPT x 1/8" Tube



5963X-100 Flexible Tubing
 59630-100: 1/16" ID.
 59631-100: 1/8" ID.



59764-4 Male Connector
 10-32 Thread x 5/32" Tube



59908 Nipple
 10-32 x 10-32 Thread



59632-1 Plug
 10-32 Thread



59903 Swivel Connector



59636 Bulkhead Fitting
 10-32 x 10-32 Thread

Features and Benefits

By utilizing a modular lockout valve the user can close off the downstream air supply for maintenance and pressure isolation. Units are threaded for direct plumbing or can be installed in the modular arrangement.

Optional filter life indicator works off of pressure differential to show a visible alert when the filter needs replacement.

A T-bracket wall mount is standard on all combo units.

The settable gauge fan is a visual reference that allows the user to display the specific pressure range that is needed for their application.

The swi
thre
a m
por
and
sen
or l
thre
by t



Use of modular threaded pipe adapters allow for ease of service by allowing a unit to be quickly removed from the air line. Adapters can be used to pipe different thread sizes in the plumbing setup.

The ARO soft-start valve allows system pressure to build gradually, protecting downstream equipment and creating a safer start-up condition.

A panel nut is standard on all individual ARO-Flo regulators and piggybacks. Must be ordered separately on combination units.

Th
va
in:
of
us
dc
fr
of
ev
pr

Op
ki
an
ad
re

Spares and Accessories

See our accessories catalog or go to our Web site for the complete selection of accessories for your application.

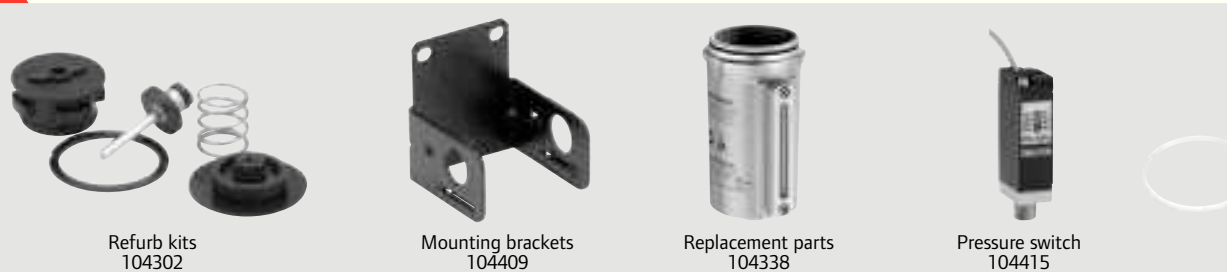

Refurb kits
104302

Mounting brackets
104409

Replacement parts
104338

Pressure switch
104415

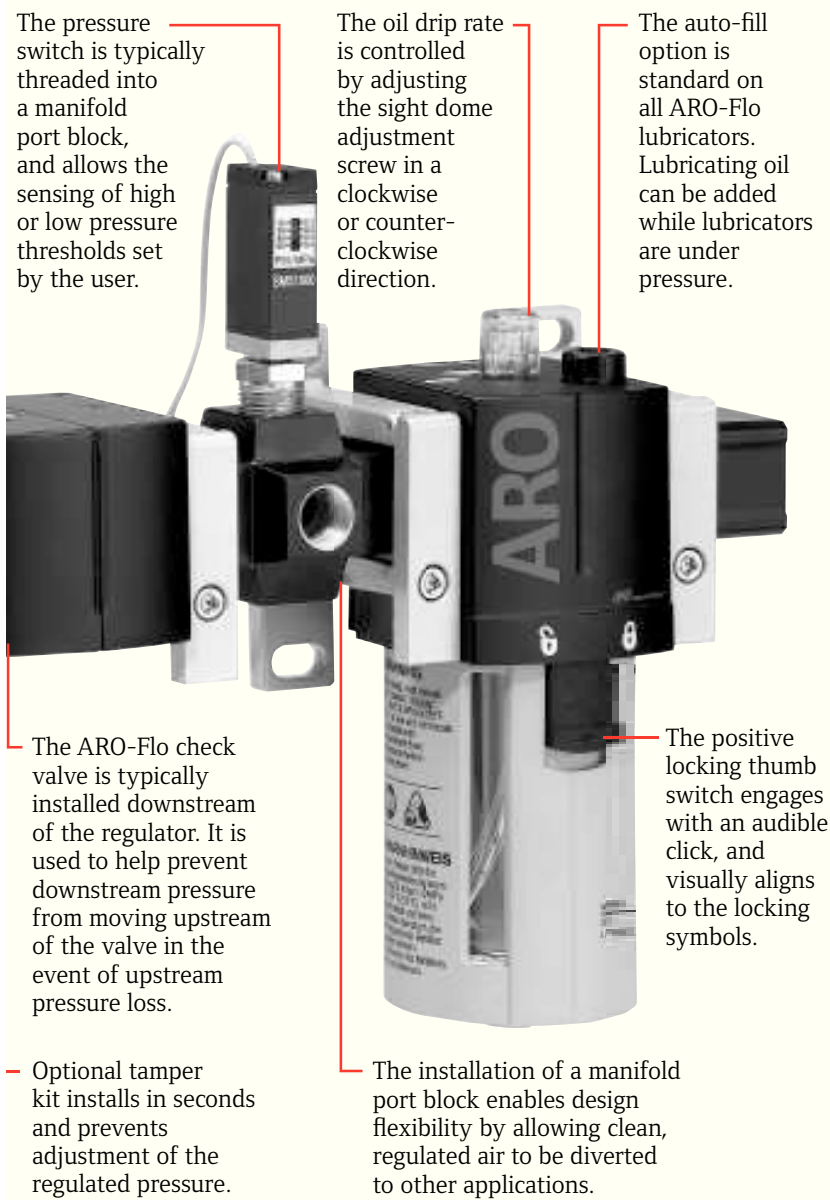

The pressure switch is typically threaded into a manifold port block, and allows the sensing of high or low pressure thresholds set by the user.

The oil drip rate is controlled by adjusting the sight dome adjustment screw in a clockwise or counter-clockwise direction.

The auto-fill option is standard on all ARO-Flo lubricators. Lubricating oil can be added while lubricators are under pressure.

The ARO-Flo check valve is typically installed downstream of the regulator. It is used to help prevent downstream pressure from moving upstream of the valve in the event of upstream pressure loss.

Optional tamper kit installs in seconds and prevents adjustment of the regulated pressure.

The installation of a manifold port block enables design flexibility by allowing clean, regulated air to be diverted to other applications.









Gauges
104334

Manifold block kit
104413-3-2

Lubricating oil
29665

Accessories

1000 Series	 <p>1000 Series 1/8" and 1/4" Ports Max flow: 59 scfm Series size: Miniature</p>
1500 Series	 <p>1500 Series 1/4" and 3/8" Ports Max flow: 113 scfm Series size: Compact</p>
2000 Series	 <p>2000 Series 3/8", 1/2", and 3/4" Ports Max flow: 222 scfm Series size: Standard</p>
3000 Series	 <p>3000 Series 3/4" and 1" Ports Max flow: 368 scfm Series size: Heavy-Duty</p>
Super-Duty Series	 <p>Super-Duty Series 1", 1-1/4", 1-1/2", 2" and 3" Ports Max flow: 1,770 scfm Series size: Super-Duty</p>
Specialty Items	 <p>Specialty Items 1/8", 1/4", 3/8", 1/2", and 3/4" Ports Specialty line</p>

Overview

Filters

ARO-Flo compressed air filters are designed to remove airborne solid and liquid contaminants. Filters can be ordered with different elements, including coalescing models which are capable of removing oil aerosols and particles down to 0.3 micron. Standard filters are sold with 5-micron elements; 40-micron elements can be purchased and installed separately.



Regulators

Air line regulators provide controlled, consistent air pressure as required for specific pneumatic equipment connected to the air system. All ARO-Flo regulators are offered with a standard adjustment range of 0 – 140 psig (0 – 9.6 barg). Alternative spring ranges are offered for easy conversion to suit different requirements. Non-relieving regulators are offered for applications where the venting of downstream overpressure is undesirable.



Lubricators

ARO-Flo mist-type lubricators help ensure that pneumatic devices receive the required lubrication to maintain peak performance, reduce wear, and prolong service life. They are designed to provide the correct amount of oil required for most general applications in a pneumatic system, delivering a constant ratio of oil to air flow. Precise oil feed adjustment sets the proper oil drip rate. Lubricators should be installed close to the downstream application to ensure effective distribution of oil.



Piggyback Filters / Regulators

Filter-regulators, or “piggybacks,” combine the functions of both a filter and regulator. Piggybacks are compact and most effective when space is a constraint. Piggybacks can be ordered with different filter elements and can be modified with different springs, depending on the filtration and air regulating requirements.



Combinations

Filters, regulators, lubricators, and piggybacks can be combined together to form combinations. They are typically strung together in the F+R+L arrangement (three-piece combo) and F/R+L (two-piece combo) arrangement, although other configurations are also used depending on application needs. ARO-Flo combination FRLs are easily assembled using modular spacer kits. Panel nuts not included with units. Must be ordered separately.



Selection

When selecting an FRL or individual filter, regulator and lubricator units, the air consumption of the tools or equipment to be serviced should be correlated with the flow capacity of the FRL. **ARO Filters, Regulators and Lubricators are designed to flow in excess of that indicated in the maximum recommended flow table shown below.** This table gives recommended flows for pipe sizes at listed pressures and should be used as a guide in sizing piping and equipment for compressed air systems.

Maximum recommended air flow (scfm) thru ANSI standard weight Schedule 40 pipe

Applied Pressure PSIG	Nominal Standard Pipe Size — Inches										
	1/8"	1/4"	3/8"	1/2"	3/4"	1"	1-1/4"	1-1/2"	2"	2-1/2"	3"
5	0.5	1.2	2.7	4.9	6.6	13	27	40	80	135	240
10	0.8	1.7	3.9	7.7	11.0	21	44	64	125	200	370
20	1.3	3.0	6.6	13.0	18.5	35	75	110	215	350	600
40	2.5	5.5	12.0	23.0	34.0	62	135	200	385	640	1100
60	3.5	8.0	18.0	34.0	50.0	93	195	290	560	900	1600
80	4.7	10.5	23.0	44.0	65.0	120	255	380	720	1200	2100
100	5.8	13.0	29.0	54.0	80.0	150	315	470	900	1450	2600
150	8.6	20.0	41.0	80.0	115	220	460	680	1350	2200	3900
200	11.5	26.0	58.0	108.0	155.0	290	620	910	1750	2800	5000
250	14.5	33.0	73.0	135.0	200	370	770	1150	2200	3500	6100

The flow values in the chart above are based upon a pressure drop (ΔP) as set forth in the following schedule:

Pressure Drop (ΔP) per 100 ft. of Pipe	Pipe Size — Inches
10% of Applied Pressure	1/8, 1/4, 3/8, 1/2
5% of Applied Pressure	3/4, 1, 1-1/4, 1-1/2, 2, 2-1/2, 3

Installation

The filter, regulator and lubricator should be installed in the order shown in the illustration below. If a coalescing filter is required, it should be installed downstream from a standard filter. Individual take-off lines to the FRL and air tool or equipment should be from the top of the compressed air line. Make sure that air flow markings are followed for proper flow direction through the FRL units.

To trap and expel water, sludge and other contaminants which may collect on the bottom of the air line, a drip leg drain should be used. Drip leg drains should be installed at low points in the piping system and at the far end of the distribution system.

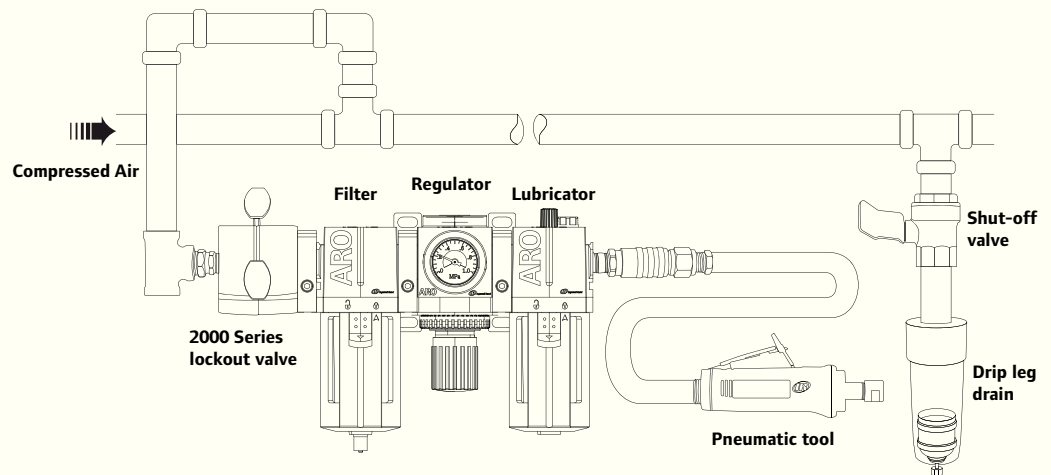

Warnings

Harmful Compressor Oils & Other Materials

Some oils used in air compressors contain chemicals harmful to Buna-N seals, if not adequately filtered at the compressor. The most common of these oils, in addition to other harmful material, are listed below.

COMPRESSOR OILS	COMPRESSOR OILS	OTHER MATERIALS
Cellulube No. 150 & 220	Phrano	Garlock No. 98403 (Polyurethane)
Haskel No. 568-023	Pydraul AC	Parco No. 3106 (Neoprene)
Houghton & Co. Oil No. 1120, No. 1130, No. 1055	Sears Regular Motor Oil Sinclair Oil "Lily White"	Some Loctite Compounds Stillman No. SR269-75 (Polyurethane)
Houtosafe 1000	Skydrol	Stillman No. SR513-70 (Neoprene)
Kano Kroil	Tenneco Anderol No. 495	
Keyston Penetrating Oil No. 2 & No. 500 Oils		
Marvel Mystery Oil		

CAUTION: Compounded oils containing graphite and fillers are not recommended for use with cylinders.

Air & Lubrication Requirement

AIR PRESSURE: Limited to 200 psig (14 bar) **FILTRATION:** 40 Micron. Proper moisture removal and filtration of contaminates will promote good service life and operation. Install an air regulator to control the operating pressure, insure smooth operation and conserve energy.

LUBRICATION: All valve components have been lubricated at the factory and can be operated without additional air line lubrication. Minimal lubrication may extend the life of the valve. 50 Series, E-Series and K-Series Valves use o-ring seals. For maximum performance and life expectancy, standard air line lubrication should be used. If air line cylinders or other air line devices, used in conjunction with ARO valve, require lubrication, be sure the lubricating oils used are compatible with the valve seals and are of sufficient viscosity to assure adequate lubrication. Aro recommends an oil lubricant with a viscosity of 100-200 SUS at 100° F and an airline point above 200° F.

NOTICE: The use of compound oils containing graphite filters, extremely low viscosities and other non-fluid lubricants is not recommended.

RECOMMENDED: Aro 29665 air line lubricator oil is available in one quart containers.

Warning

The following are hazards or unsafe practices which could result in severe personal injury, death or substantial property damage. Heed the following. Use safeguards. Insure that provisions are made to prevent the valve from being accidentally operated (actuated.)

Hazardous Air Pressure. Shut off, disconnect and relieve any trapped air pressure from system before performing service or maintenance.

Hazardous Voltage. Do not attempt any service without disconnecting all electrical supply sources.

NOTICE: Genesis Series Valves must be grounded.

Do not use the valve as a safety device or to operate or control the operation of full revolution clutch systems or brake systems on power presses or similar equipment. These valves are not intended for such applications. Do not subject the valve to any condition that exceeds the limits set forth in the specifications for a particular valve model. Keep all hoses, electrical wiring, fittings and connections in good working condition. Damaged air pressure hoses, electrical wiring, or connections, could cause accidental valve operation (actuation). Only allow qualified technicians to install or maintain the valve system. It is necessary to have a thorough understanding of the operation and application of all valves being used in a particular system and how they interact with

General Information

To obtain information or to receive technical literature for specific valves: contact ARO Customer Service at (800) 495-0276 or contact your nearest Aro distributor. Refer to the Service Kit Director for Valves and Cylinders form #9326-M, available from Aro. Selected parts are provided in kit form. The ARO Parts List/Service Instructions contain Repair Kit information and complete Service Parts information and are available upon request. Order Manuals as shown. The following Operator's Manuals are available.

<u>Operator's Manual</u>	<u>Part Number</u>
ALPHA SERIES	119999-015
CAT SERIES	119999-036
E SERIES	119999-034
GENESIS SERIES	119999-021
H SERIES	119999-037
K SERIES	119999-035
50 SERIES	119999-045

5 Year Warranty

Ingersoll Rand/ARO® warrants to the user purchaser of the ARO® products depicted in this catalog that the products be free of defects in material and workmanship for a period of five (5) years from the date of purchase.

ARO® will repair or replace, at its election, any product which is found upon its inspection to be defective during the period prescribed above. The product must be shipped prepaid to ARO® factory or ARO® Customer Service Center together with proof of purchase.

This warranty does not apply to failures or defects occurring as a result of abuse, misuse, negligent repairs, corrosion, erosion and normal wear and tear.

THIS WARRANTY IS IN LIEU OF ALL OTHER WARRANTIES (EXCEPT TITLE), EXPRESSED OR IMPLIED, AND THERE ARE NO WARRANTY OF MERCHANTABILITY OR FITNESS FOR PARTICULAR PURPOSE IS INTENDED OR MADE .

THE REMEDIES OF THE USER PURCHASER SET FORTH UNDER THE WARRANTY OUTLINED ABOVE ARE EXCLUSIVE AND THE TOTAL LIABILITY OF ARO WITH RESPECT TO THIS TRANSACTION, WHETHER BASED ON CONTRACT, WARRANTY, NEGLIGENCE, INDEMNITY, STRICT LIABILITY OR OTHERWISE SHALL NOT EXCEED THE PURCHASE PRICE OF THE PRODUCT.

ARO SHALL IN NO EVENT BE LIABLE TO THE USER PURCHASER FOR ANY CONSEQUENTIAL, INCIDENTAL, INDIRECT, SPECIAL OR PUNITIVE DAMAGES ARISING OUT OF THIS TRANSACTION, OR ANY BREACH THEREOF, WHETHER OR NOT SUCH LOSS OR DAMAGE IS BASED ON CONTRACT, WARRANTY, NEGLIGENCE, INDEMNITY, STRICT LIABILITY OR OTHERWISE.

Progress in Motion

For more than 100 years, we've helped drive innovation with revolutionary technology — creating new standards for how the world gets work done. We've done it by producing class-leading ARO® pump and dispensing technologies, and by knowing our customers' industries and the demands placed on productivity and quality.

No matter what your product, process, or location, ARO® offers a broad range of pumps and accessories, fully customizable dispensing systems, and a worldwide distribution and service network guaranteed to solve any fluid handling challenge.



Piston Pumps

ARO® Piston Pumps are used in some of the toughest applications throughout industry. This broad range of pumps are used with low-to-high viscosity fluids for general transfer, fluid recirculation and extrusion.

Extrusion Packages

Extrusion Packages allow you to get an application up and running as easily as possible. These are divided into three categories: lift mount, single-post rams and two-post rams. In all cases, the package comes ready to use, no assembly required. Attach an outlet hose, fluid container and air supply, and your ARO® Extrusion Package is up and running.

Dispensing Systems

Ingersoll Rand Dispense Systems creates turnkey systems for automatic and manual dispensing applications. Our complete dispensing solutions are configured from standard components to meet customer specific requirements for applications within many different industries.

Lubrication Equipment

ARO® lubrication equipment has a full range of products that will keep all types of fluids moving efficiently. They are backed by more than 70 years of experience in pump and air system technology, and include models specifically designed for popular applications.

Pneumatic Valves

ARO® offers a full line of pneumatic valves to meet all your needs. Valves are offered in configurations of 2-, 3-, and 4-Way, available with electric, manual, mechanical, and pneumatic actuators. Miniature to full size valves to fit any application. A line of accessory and specialty valves are also available.

Pneumatic Cylinders

Small bore non-repairable interchangeable cylinders, round and square compact, interchangeable cylinders perfect for OEM and MRO applications, as well as medium-heavy duty round line repairable cylinders. NFPA, interchangeable cylinders are available in extruded aluminum barrel up to 4" bore and in an entirely stainless steel cylinder with tie rod construction up to 8" bore.

Air System Components

With ARO® brand filters, regulators, and lubricators (FRLs) in your operation, you get a cost-effective solution to increasing the life of your pneumatic equipment. You can save space, time, and piping costs. Our FRLS also give you greater mounting flexibility and convenience.



ARO[®]

Ingersoll Rand (NYSE:IR) advances the quality of life by creating and sustaining safe, comfortable and efficient environments. Our people and our family of brands—including Club Car[®], Ingersoll Rand[®], Schlage[®], Thermo King[®] and Trane[®]—work together to enhance the quality and comfort of air in homes and buildings; transport and protect food and perishables; secure homes and commercial properties; and increase industrial productivity and efficiency. Ingersoll Rand products range from complete compressed air systems, tools and pumps to material handling systems. The diverse and innovative products, services and solutions enhance our customers' energy efficiency, productivity and operations. We are a \$14 billion global business committed to a world of sustainable progress and enduring results. For more information, visit ingersollrand.com.



www.ingersollrandproducts.com/ARO

arohotline@irco.com

(800) 495-0276

youtube.com/aropumps

Distributed by:



Ingersoll Rand, IR and the IR logo are trademarks of Ingersoll Rand, its subsidiaries and/or affiliates. All other trademarks are the property of their respective owners.

Ingersoll Rand compressors are not designed, intended or approved for breathing air applications. Ingersoll Rand does not approve specialized equipment for breathing air applications and assumes no responsibility or liability for compressors used for breathing air service.

Nothing contained on these pages is intended to extend any warranty or representation, expressed or implied, regarding the product described herein. Any such warranties or other terms and conditions of sale of products shall be in accordance with Ingersoll Rand's standard terms and conditions of sale for such products, which are available upon request.

Product improvement is a continuing goal at Ingersoll Rand. Designs and specifications are subject to change without notice or obligation.

We are committed to using environmentally conscious print practices

©2014 Ingersoll Rand IRITS-0214-049